



StocksAG

Fan Jet Duo VS-2

ORIGINAL OPERATING MANUAL & PARTS LIST



Read carefully before installation and operation

This document must not be copied duplicated or distributed without prior consent.
All and patent rights apply.



Stocks Ag Limited.

Cromwell Road, Wisbech, Cambridgeshires, PE14 0SD, UK
01945 464909 sales@stocks-ag.co.uk www.stocks-ag.co.uk



Index

Section		Page
	E.C. DECLARATION OF CONFORMITY	4
	UKCA. DECLARATION OF CONFORMITY	5
1.0	General Information	6
1.1	Technical Data	6
1.2	Intended Use	6
1.3	Unintended Use	6
1.4	Machine Identification	7
1.5	Warranty	7
2.0	Safety	8
2.1	Safety Warning Decals	9
3.0	Emergency Stop Instructions	10
4.0	Storage	10
5.0	PVC Waterproof Covers	10
6.0	Disposal	10
7.0	General Maintenance	11
7.1	Before Use	11
7.2	Daily Checks	11
7.3	After Each Use	11
8.0	Installation Guide	12
8.1	Central Beam Assembly	12
8.2	UTV Fitting Kit	12
8.3	UTV Fitting Kit Parts	13
8.4	Central Beam Assembly	14
8.5	Central Beam Assembly Parts List	15
8.6	Mounting Plate	16
9.0	Hopper Emptying Procedure	17
9.1	Clearing a Blockage	17
9.2	Hopper Level Sensor	17
10.0	Electrical Components	18
10.1	Electrical Connections	18
11.0	Cab Control Panel	19
12.0	Control System Operation	20
13.0	GPS Kit	21

Index

Section		Page
14.0	Setting The Feed Rate	22
14.1	Changing The Feed Rollers	22
14.2	Feed Roller Configuration	22
15.0	Calibration Hopper	23
15.1	Fitting Instructions	23
16.0	Control Panel Calibration	24
16.1	Calibration Switch	24
16.2	Spread Bias Adjustment	25
17.0	Spread Width & Pattern	26
18.0	Product Calibration	27
19.0	Calibration Catch and Weigh Test	28
19.1	Feed Motor Settings & Speeds (RPM)	28
20.0	Fan Jet Duo Plus Parts Diagram	29
20.1	Fan Jet Duo Plus Parts List Page 1	30
20.2	Fan Jet Duo Plus Parts List Page 2	31
20.3	Fan Jet Duo Plus Parts List Page 3	32



E.C. DECLARATION OF CONFORMITY

Machine Type: Mounted Agricultural Implement - Pellet and Seed application broadcasters

Model(s):	Fan Jet Pro	All Variants and Versions
	Fan Jet Pro Plus	All Variants and Versions
	Fan Jet Twin	All Variants and Versions
	Fan Jet Mini	All Variants and Versions
	Fan Jet Duo	All Variants and Versions
	Turbo Jet	All Variants and Versions
	Rotor Meter	All Variants and Versions
	Rotor Meter Air Force	All Variants and Versions
	Micro Meter	All Variants and Versions
	Maxi Meter	All Variants and Versions

Serial No.

Manufacturer: Stocks Ag Ltd
Cromwell Road
Wisbech
Cambridgeshire PE14 OSD
United Kingdom

This is to declare that the above machine conforms to the relevant Essential Health and Safety Requirements of the Machinery Directive 2006/42/EC, implemented in the United Kingdom by Statutory Instrument 2008 No. 1597 – The Supply of Machinery (Safety) Regulations 2008 as amended.

The following standards have been applied in the design and construction of this machine:

BS EN ISO 12100:	2010	Safety of machinery – General principles for design – Risk assessment and Risk reduction.
BS EN ISO 4254-1:	2015	Agricultural machinery – Safety - General requirements.
BS EN ISO 4254-8:	2018	Agricultural machinery. Safety - Solid fertilizer distributors
BS EN ISO 13854:	2019	Safety of machinery – Minimum gaps to avoid crushing of parts of the human body.
BS EN ISO 13857:	2019	Safety of machinery – Safety distances to prevent hazard zones being reached by the upper and lower limbs.

The manufacturer stated above holds the technical file for this machine.

Signed on behalf of Stocks Ag Ltd

Name:..... **J Woolway**

Date: 06th August 2020

Position: Managing Director



t. +44 (0) 1945 464909 f. +44 (0) 1945 464985 e. sales@stocks-ag.co.uk



UKCA. DECLARATION OF CONFORMITY

Machine Type: Mounted Agricultural Implement - Pellet and Seed application broadcasters

Model(s):	Fan Jet Pro	All Variants and Versions
	Fan Jet Pro Plus	All Variants and Versions
	Fan Jet Twin	All Variants and Versions
	Fan Jet Mini	All Variants and Versions
	Fan Jet Duo	All Variants and Versions
	Turbo Jet	All Variants and Versions
	Rotor Meter	All Variants and Versions
	Rotor Meter Air Force	All Variants and Versions
	Micro Meter	All Variants and Versions
	Maxi Meter	All Variants and Versions

Serial No.

Manufacturer: Stocks Ag Ltd
Cromwell Road
Wisbech
Cambridgeshire PE14 OSD
United Kingdom

This is to declare that the above machine conforms to the relevant Essential Health and Safety Requirements of the Machinery Directive 2006/42/EC, implemented in the United Kingdom by Statutory Instrument 2008 No. 1597 – The Supply of Machinery (Safety) Regulations 2008 as amended.

The following standards have been applied in the design and construction of this machine:

BS EN ISO 12100:	2010	Safety of machinery – General principles for design – Risk assessment and Risk reduction.
BS EN ISO 4254-1:	2015	Agricultural machinery – Safety - General requirements.
BS EN ISO 4254-8:	2018	Agricultural machinery. Safety - Solid fertilizer distributors
BS EN ISO 13854:	2019	Safety of machinery – Minimum gaps to avoid crushing of parts of the human body.
BS EN ISO 13857:	2019	Safety of machinery – Safety distances to prevent hazard zones being reached by the upper and lower limbs.

The manufacturer stated above holds the technical file for this machine.

Signed on behalf of Stocks Ag Ltd

Name:  J Woolway

Date: 01st December 2020

Position: Managing Director

t. +44 (0) 1945 464909 f. +44 (0) 1945 464985 e. sales@stocks-ag.co.uk



1.0 General Information

Congratulations on your Fan Jet Duo purchase:

Please check the machine for any transport damage upon receipt and advise your supplier of any problems immediately. Late claims regarding any damage may be rejected.

Specifications descriptions and illustrations in this manual are accurate at the time of this publication but may be subject to change these manual was correct at the time of printing but we reserve the right to change and improve them. This machine is designed with safety in mind.

Maintenance and servicing in accordance with this manual will ensure safe operation and reliability of your machine for many years.

This Operating Manual forms part of the machine and must be readily available for the operator who must read and follow the points covered before use.

Model: Fan Jet Duo Plus VS-2

Hopper capacity: 1x 65 litre or 2x 130 litre

***Combined data for both left and right hand machines**

65 litre machine:

130 litre machine:

Net weight: 90kg

Net weight: 98kg

Dimensions: (WxDxH) 50 x 56 x 82cm
(boxed 52cm x 58cm x 85cm)

Dimensions: (WxDxH) 61 x 61 x 95cm
(boxed 62cm x 62cm x 98cm)

Max spreading width: 36m

Recommended working width: 18-36m

***Operating Voltage:** 12v

***Motor outputs:** 720 watts

***Power Requirement:** 60 amps

***Noise level:** 95dB

1.2 Intended Use

This Fan Jet Duo has been designed for use in the agricultural, horticulture, and amenity sector to apply large dense slug pellets from 18-36m and various small seeds and granular products to varying widths depending upon the seed or product density. Can also be used for game cover cropping and as a game feeder.

The applicator can be mounted to operate facing forwards or backwards. Often mounted on the rear of drills and sets of rolls to apply slug pellets.

If mounting to a self propelled crop sprayers or tractor front linkage we recommend the use of our purpose built Central Mounting Beam and for suitable UTV vehicles our UTV fitting kit.

NOTE: When fitting to a UTV vehicle the minimum alternator output required is **55amps** and the maximum spread width is limited to a maximum of **32m** due to the power supply available and height of machine when mounted.

Any other use is considered to be unintended and the manufacturer will not be liable for any resulting damage.

The manufacturer is not liable for any resulting damage if the machine is used for any other purpose than the intended use and also includes compliance with the conditions for operation, maintenance, and repairs prescribed within this instruction manual.

The applicable accident prevention regulations as well as the other generally safety-related, occupational health and road traffic regulations must also be observed.

1.3 Unintended Use

This machine is not designed to apply abrasive materials such as sand & grit or for applying salt products.

The operator alone bears the associated risk if used for non-intended use.

2.0 Safety

Ensure care is taken when lifting the machine. Safe lifting practice to be observed when handling as the net weight is over 25kg.



- We advise safety shoes and protective gloves are worn when handling the machine.
- Assistance will be required when lifting or lowering the machine.
- Care to be taken to avoid crushing due to the weight of the machine.
- When lifting or fitting the machine on to a parent vehicle or implement ensure work is performed on level ground or flat surface to avoid slipping, stumbling or falling.

PERSONAL PROTECTION EQUIPMENT

It is the responsibility of the operator or maintenance engineer to ensure safe handling of the machine and the appropriate personal protection equipment must be worn for the material being applied and to prevent contamination to the machine or the environment.

⚠ WARNING! Ear protection required if working in close proximity to the machine as it exceeds 80dB.

PRODUCT APPLIED

If applying slug pellets or other toxic material and the parent vehicle has a closed cab the operator must ensure the cabin is always closed and the air filter system is in good order. If fitted to a UTV vehicle ensure the stability of the parent vehicle is not affected when the machine is in use. If in doubt contact the vehicle manufacturer for more information. After working the machine ensure that any unused product is returned safely to its original packaging. Stocks Ag Ltd. does not accept any liability for the storage and use of the material being applied.

NOTE: If unsure contact your seed or product supplier for more information.

⚠ WARNING! Always observe all application standards and guidelines provided by the product manufacturer as some seed dressings and granular products may be toxic.

OPERATION AND MAINTENANCE

The machine may only be used, maintained and repaired by persons who have relevant experience or a machinery dealer who is aware of any risks involved. The applicable accident prevention regulations as well as the other generally safety related, occupational health and road traffic regulations must also be observed.

The manufacturer is not liable for any damage resulting from unauthorised modifications and the use of components and auxiliary parts. The machine must be checked regularly by the operator (before each use) for any damage, loose bolts or electrical connections, vibrations, unusual sounds, and to ensure they function correctly.

The machine must not be operated in wet weather conditions or during thunderstorms. Observe the generally applicable safety and accident prevention regulations. Always empty the hopper of toxic materials to prevent harm to humans and animals after each use and prior to storage.

⚠ WARNING! Do not put your hands inside the hopper when the agitator motor is turning as the agitator shaft inside the hopper rotates at high speed and is sharp and dangerous.

⚠ WARNING! Always isolate the power supply if servicing or leaving the machine unattended.

2.1 Safety Warning Decals

Important: Be aware of the safety warning below which are all relevant to this machine



⚠ WARNING!

Read and understand the Operators Manual instructions before operating this machine.

Operator errors can result in serious injury.



⚠ WARNING!

Danger due to thrown or flying objects.

Always maintain a safe distance whilst the machine is in operation.

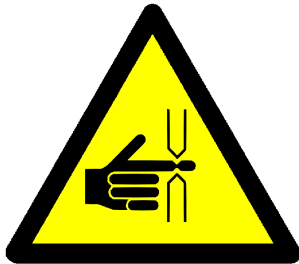

⚠ WARNING!

Risk of injury. Possible trapping point when tipping hopper.



⚠ WARNING!

Risk of injury.

Be aware the feed mechanism is powerful and can cause serious injury.



⚠ WARNING!

Keep Clear!

Maintain a safe distance from the machine when in operation.

Wear the appropriate protective personal equipment.



⚠ WARNING!

Do Not Jet Wash. This machine is not designed to withstand Jet Washing.

3.0 Emergency Stop Instructions

In the case of an emergency always switch off the main power switch on the control panel and isolate the power supply immediately by disconnecting the power cable.



4.0 Storage

Disconnect the power supply by unplugging the power cable or by removing the 60amp fuse fitted in the power cable.

It is the responsibility of the operator to ensure the hopper is empty after use and cleaned thoroughly before storage.

Store in dry conditions to protect the machine and control system from moisture.

Always clean and spray electrical connectors with a moisture repellent spray when not in use for long periods.

Fit the PVC waterproof cover (if available).

Ensure feed blocks are free to turn and all electrical cables checked following periods of storage.

5.0 PVC Waterproof Covers - Optional

Heavy duty White PVC covers fitted with eyelets and bungie cord for easy attachment available for all machines.

Please contact your locals Stocks Ag dealer for more information.

Heavy duty White PVC covers available - sold separately.

65L Waterproof PVC Covers- **Part No. LC65DUO**

130L Waterproof PVC Covers- **Part No. LC130DUO**



6.0 Disposal

Ensure that any persons handling the machine are aware that the machine may have been used to apply toxic chemicals and so the appropriate personal protection equipment should be worn.

Ensure the hopper contents have been removed and any toxic residue removed and put back into a sealed container or disposed of in accordance with the manufacturers guidelines to eliminate any possible contamination of others or the environment.

Always adhere to the local disposal regulations paying particular attention to the plastics, rubber, and electrical components.

7.0 General Maintenance

⚠ WARNING! Always ensure the power supply is disconnected before any maintenance work or cleaning of this machine.

The machine must be checked regularly by the operator for any damage loose bolts or electrical connections, vibrations, unusual sounds, and to ensure they function correctly.

⚠ WARNING! Protective clothing must be worn when applying or handling toxic products

Always observe all guidelines provided by the product manufacturer with regards to handling, storage and disposal of products. Take care not to spill any product that could contaminate the machine or the environment ensuring any product removed from the machine is put back into its original container.

7.1 Before Use

1. Ensure the machine is securely mounted.
2. Check the power supply is connected to the vehicle battery.
3. Check the feed block assembly to ensure the feed rollers are clean and replace any worn feed rollers.
4. Check the feed rollers rotate freely before starting work.

7.2 Daily Checks

1. Check the disc to motor shaft socket screws on the lower side of the spinning disc to ensure they are tight and the spinning turns with the motor.
2. Check the stainless disc vanes for any wear or distortion and replace prior to use if necessary. Vane kit available if required: Part number FJ009C (set of vanes and fixings for one disc assembly).
3. Check the feed block assembly to ensure the feed rollers rotate freely.

7.3 After Each Use

1. Empty hopper before removing the feed block assembly and clean the machine thoroughly ensuring all pellets residue has been cleaned from the hopper feed rollers and body of the machine.
2. Store in dry conditions to protect the machine and control system from moisture.

⚠ WARNING!

DO NOT JET WASH THIS MACHINE.



8.0 Installation Guide

Safe lifting practice to be observed when handling the machine as the net weight is over 25kg.

Safety shoes and protective gloves to be worn when handling the machine.

With a full hopper the 65L machine could weigh in excess of 80kg and the 130L machine 135kg and so ensure the machine is securely attached to a suitably strong rigid mounting point.

We recommend front mounting direct to the chassis of self propelled sprayers or tractor front linkage, using the bolt holes provided in a large vertical bracket of the central beam assembly.

NOTE: Many self propelled sprayer manufacturers offer a suitable bracket or hydraulic raise and lower linkage for this purpose.

Locally fabricated mounting frames are not the responsibility of Stocks Ag Ltd. If unsure seek advise from the parent machine manufacturer or supplier.

Ensure the disc height is a minimum of 1.5 metre above the crop canopy or the ground – more height may improve the maximum spread width. **(minimum disc height of 2m required for 36m work).**

Ensure the power cable is connected direct to the parent vehicle 12v battery and the fuse is fitted correctly.

Always adhere to Health and Safety guidelines when mounting or fabricating an appropriate mounting frame and always wear suitable protective clothing.

8.1 Central Beam Assembly - Optional

Central Beam:-Part No. FJ-005-BEAM-600 (available through your local dealer).



Heavy duty tubular design offers a sturdy support for the two hopper units when fitting to the front of a SP sprayer or tractor.

Approx. dimensions of unit when assembled

65L machines (W) 960x (H) 700x (L) 1250

Approx. weight 130kg

130L machines (W) 960x (H) 700x (L) 1350

Approx. weight 135kg

8.2 UTV Fitting Kit - Optional

UTV Fitting Kit: Part Number FJ-005-UTV2 (available through your local dealer).

Offering a sturdy fitting option for most UTV fitments with 4 hooked anchor points with hand release fittings.

One piece tubular steel construction with detachable machine mounting plates.

Fixed fork lift point offers safe and easy lifting on and off of vehicle.



8.3 UTV Fitting Kit Parts -Optional

Part No. FJ-005-UTV (available through your local dealer).

Offering a sturdy fitting option with 4 hooked anchor points with hand release fittings our UTV kit is suitable for most common UTV fitments.

One piece tubular steel construction with detachable machine mounting plates with fixed fork lift point for safe and easy lifting on and off of vehicle.

Standard dimensions: 1220mm wide x 900mm deep x 350mm high

Will Fit: JD Gator XUV 855M (Bed Size 132cm x 114cm) Polaris Ranger Diesel (Bed Size 137cm x 92cm).

Kubota 1140 (Bed Size 146cm x 135cm) Kubota 900 (Bed Size 146cm x 103cm).

Kawasaki Mule Pro-DX (Bed Size 137cm x 92cm) Can-Am Traxter HD8 DPS (Bed Size 143cm x 98cm).

Modified versions available for: Polaris Ranger XP1000 (Bed Size 139cm x 880cm).

Honda Pioneer SXS (Bed Size 115cm x 93cm).

If your vehicle is not listed please enquire.

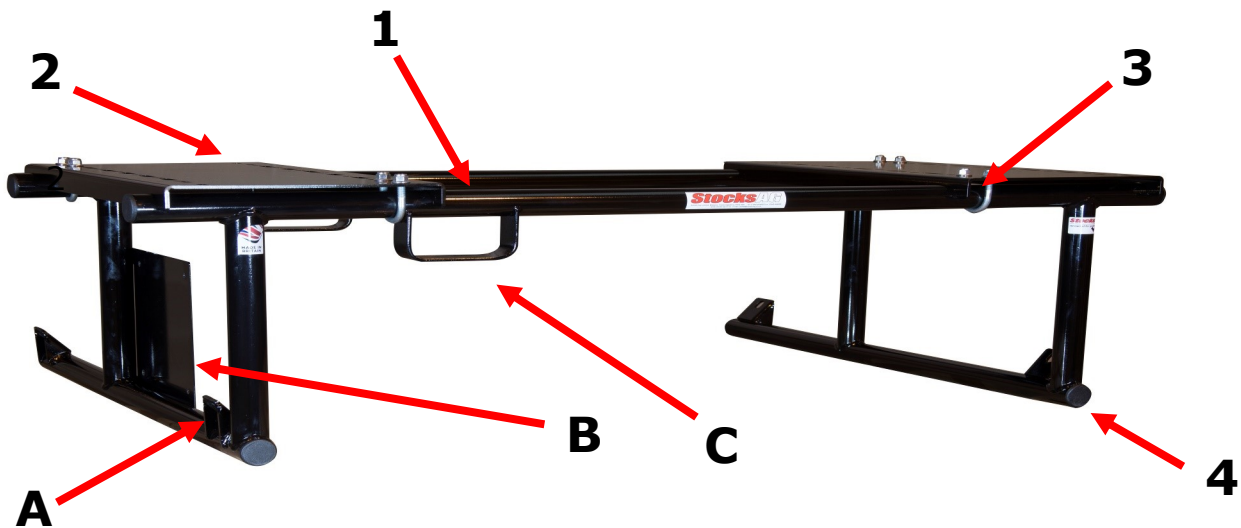

Item	Part No.	Description	Qty.	Remarks
1	FJ800A	Main Frame		
2	FJ805	Machine Mounting Plate	2	
3	FJ810	"U" Bolt	8	
4	FJ811	Protective PVC End Cap	8	
5	FJ809	M12 PVC Handwheel	4	(not shown)
6	FJ807A	Retaining Hook	4	(not shown)
7	FJ814	*Underfloor Strengthening Bar		Cost option (not shown)
		*available upon request to reinforce the floor area of the UTV if required to enable mounting points to be used		
A		Fixing Points	4	
B		Plate for VS-2 Control Junction Box	1	
C		Forklift Point	1	

8.4 Central Beam Assembly - Optional

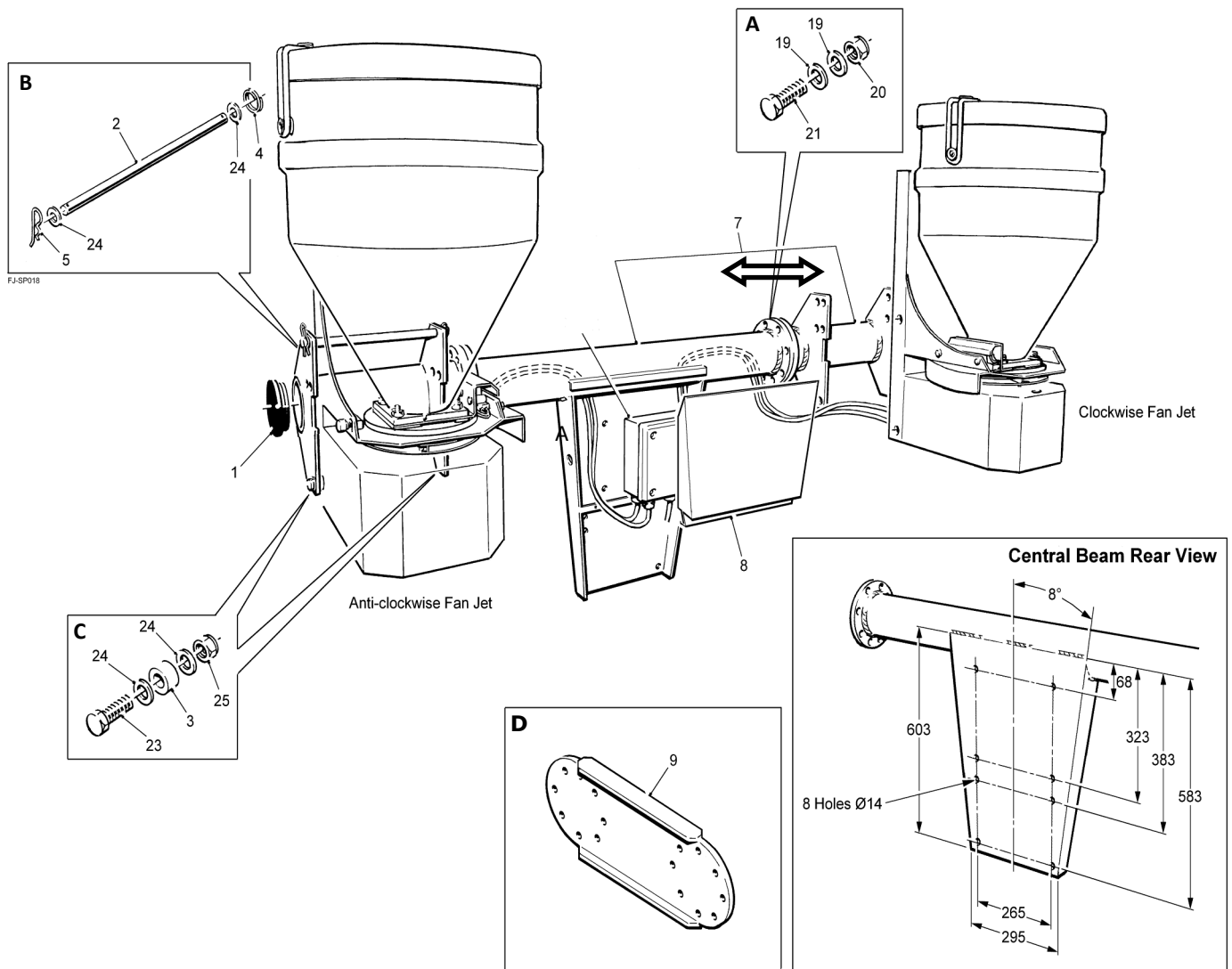

Ensure care is taken when lifting and securing the central beam to the parent vehicle and when fitting the machines onto the beam.

Safe lifting practice to be observed when handling each component each net weight is over 25kg.



1. Attach the two outer beam sections to the centre section (7) using the fixing bolt kit (fig A) provided ensuring not to trap the electrical supply cables.

2. Attach machines to the outer beam section by using the tipping pin components (fig B) and pivot fixing bolts and spacers (fig C) provided. The steel tipping pins then secured in position by the 'R' clips (5).

NOTE: There are 2 positions for the pin – use these to help level the Fan Jet.

3. Connect all electrical cables to each Fan Jet unit as required.

Ensure there is sufficient room to tip the hopper for emptying and ensure any potential trapping points are noted taking care not to trap hands or fingers. The machine must be on level ground or flat surface before tipping the hopper to avoid the hopper accidentally tipping forward once the tipping pin has been removed. To tip the hopper, remove the pin whilst supporting the hopper, lower gently when emptying the hopper.

NOTE: Adaptor plates shown in fig D are not included as part of the standard kit. (For more information contact your local Stocks Ag dealer).

8.5 Central Beam Assembly Parts List

Part No: FJ-005-BEAM-600

Item	Part No.	Description	Qty.	Remarks
1	FJ090A	Ø114.3 PVC End Cap	2	
2	FJ415D	Tipping Plate Pin	1	
3	FJ417A	Nylon Spacer	1	
4	FJ418A	Split Ring	1	
5	FJ419A	3mm 'R' Pin	2	
8	FJ630A	Guard Panel	1	
9	FJ601B	Adaptor Plate Kit (pair of adaptor plates c/w fixings)	--	Cost Option (please enquire)
19	M10-016	M10 Flat Washer	32	
20	M10-024	M10 Nyloc Nut	16	
21	M10-009	M10x40 Set Screw	16	
22				
23	M12-006	M12x40 Screw	4	
24	M12-008	M12 Flat Washer	12	
25	M12-014	M12 Nyloc Nut	4	

8.6 Mounting Plate - Optional

Part No. FJ-005-TIP (available through your local dealer).

Machines are best mounted to our purpose built Central Beams or UTV kits, but can also be mounted by using these optional tipping base plate kits. These have 4 holes in the base to take M12 bolts (see below) use these to attach to any support fabrication. The base plate can be repositioned to fit the holes in the back of the machine to attach to a vertical mounting point – use whichever is best for you.

Ensure there is sufficient room to tip the hopper for emptying and ensure any potential trapping points are noted taking care not to trap hands or fingers.

The tipping base plate is attached to the chassis by 2 bolts and spacers which act as the pivot and a removable steel pin secured by an 'R' clip (**as when fitting to the optional Central Beam or UTV kit**). There are 2 positions for the pin – use these to help level the Fan Jet.

The machine must be on level ground or flat surface before tipping the hopper to avoid the hopper accidentally tipping forward once the tipping pin has been removed.

To tip the hopper, remove the pin whilst supporting the hopper, lower gently when emptying the hopper.

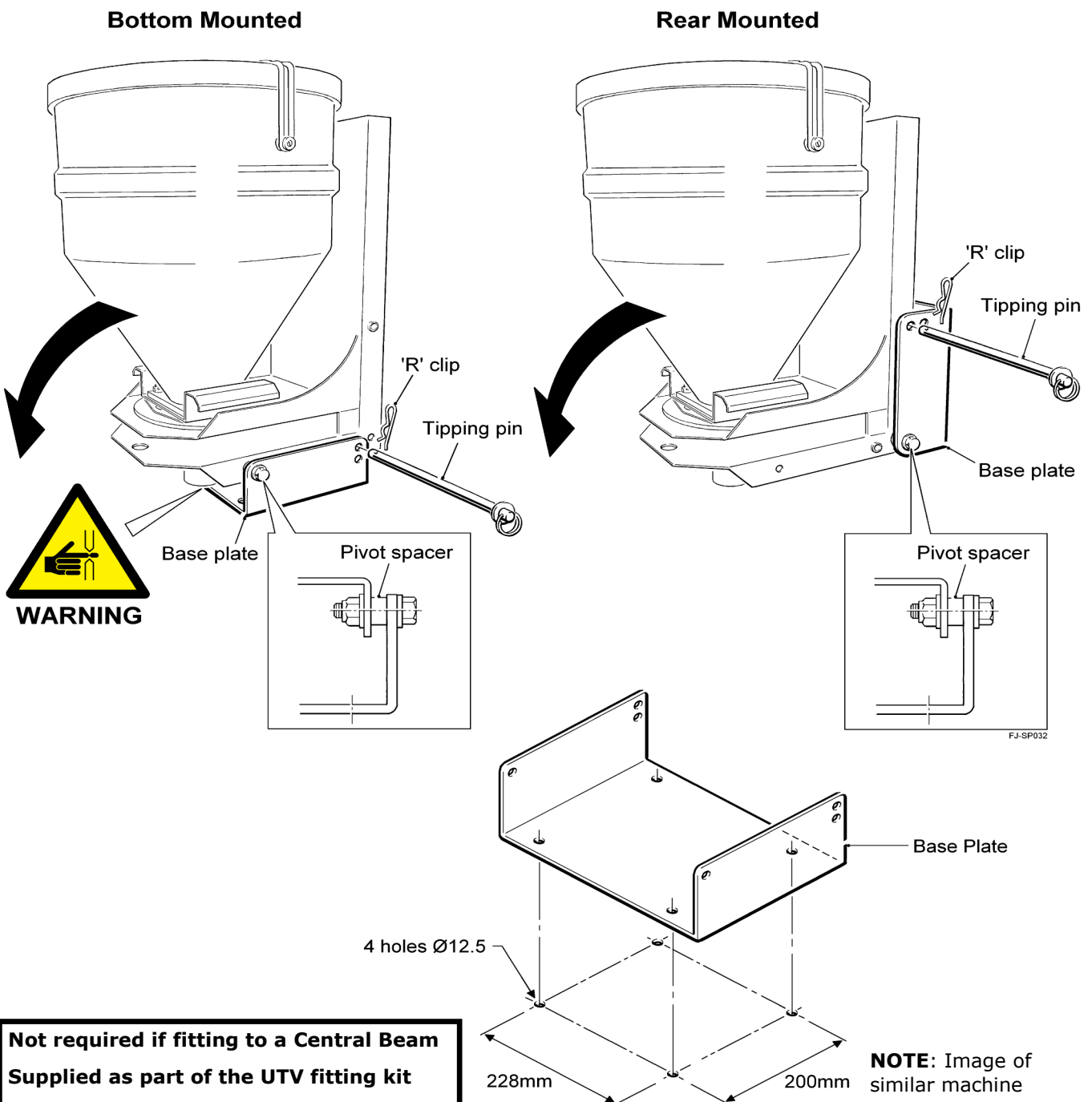

9.0 Hopper Emptying & Removal Procedure

Removing the hopper for cleaning and maintenance.

Ensure appropriate personal protection equipment is worn for the product being applied.

Ensure there is sufficient room to tip the hopper for emptying and ensure any potential trapping points are noted, taking care not to trap hands or fingers.

NOTE: The machine must be on level ground or flat surface before tipping the hopper to avoid the hopper accidentally tipping forward once the tipping pin has been removed.

Release the rubber lid retaining straps and remove the lid.

To tip the hopper, remove the R Clip and washer. Whilst supporting the hopper, remove the Tipping Pin, lowering gently when emptying the hopper through the three outlet holes in the top. When replacing the hopper ensure the gasket fitted under the base of the hopper is in good order.

Replace if damaged: Part number FJ017S.

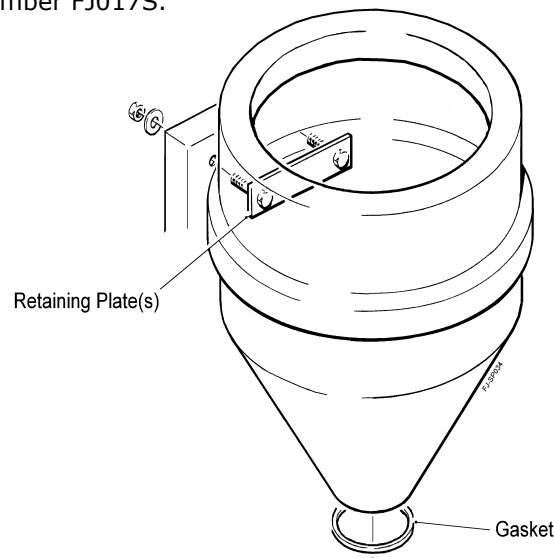

9.1 Clearing A Blockage

Switch off the main power switch on the control panel.

Ensure the parent machine is stationary, switched off and parked on level ground.

Ensure the main power switch on the control panel is off and unplug the 2 core power supply cable from the control box or disconnecting the power cable from the vehicle battery.

Ensure appropriate personal protection equipment is worn for the product being applied.

Ensure any product removed is put back into its original container. Care to be taken not to spill any product that could contamination the environment.

Empty the hopper of any remaining product.

9.2 Hopper Level Sensor - Optional

This optional hopper level sensor can be fitted to one of the two hoppers.

The alarm will sound once the product in hopper drops below the level of the sensor.

Recommended if the hoppers are not in full view of the operator.



Part No. TJ-004-HLS-KIT

10.0 Electrical Components

1. Cab Control Panel.
2. Junction box (mount in central of mounting beam or fix to mounting plate B on the UTV frame).
3. Left hand machine (ACW) disc motor and feed motor power cables.
4. Right hand machine (CW) disc motor and feed motor power cables.
5. Calibration switch and wiring loom.
6. Control cable connection.
7. Power cable connection.
8. GPS sensor connection.
9. 6m control extension cable (not shown).
10. 5m fused power cable.
11. 5m power cable extension (not shown).

Note: Power and control extension cables available.



10

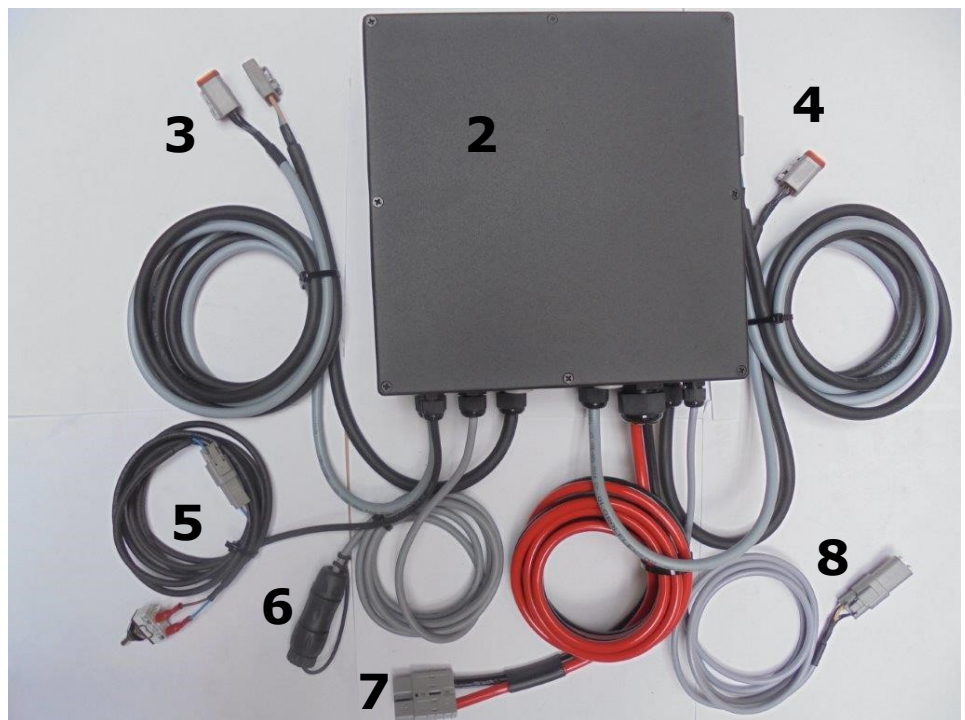

10.1 Electrical Connections

Ensure the power supply cable is connected directly to the vehicle battery to ensure maximum power.

Connect the positive wire (fused) to the positive (+) terminal and negative earth connection to the negative (-) terminal. The right hand disc should rotate in a clockwise direction, the left hand disc should rotate in an anticlockwise direction when viewed from above.

Failure to connect to the vehicle battery may result in control function problems and possible damage to the vehicle battery and charging system must be in good condition to achieve the best results. All cables and controls are fitted with matching plugs and sockets. Extension cables available.

Any modification to the wiring, fuse holder or controls will invalidate any warranty claim and may affect the performance of the Fan Jet.

Always replace any blown fuse with the same rated fuse as the original one fitted.

11.0 Cab Control Panel

A simple and effective manually operated electric control used to instantly start and stop the feed motor at headlands, and uses a dial control to set the feed motor speed and thus the application rate. It is not linked to forward speed so once calibrated the operator drives at a consistent forward speed to maintain the rate, or can manually increase or decrease application rates on the move using the dial.

NOTE: Optional GPS Kit available to link the application rate to forward speed.

The console is intended to be used in a waterproof in-cab environment, and should be mounted in a convenient position using the mounting clips provided. Do not drill or open the box.

The console connects to the main junction box via a waterproof connector in the control cable, and remains live unless this control cable or the main power cable is disconnected. Extension connector cables are available if required. **Do not modify the control console: this will invalidate any warranty claim.**

The control console has 4 x toggle switches, and 2 x 12 position rotary dials and 3 LED's, which are used to control the spinning discs and the variable speed 12v feed motors.

The LED lights above each of the toggle switches indicate the status of the function.

●=System OK ●= Stop and investigate cause. An audible alarm will also indicate a change of status.

1. Feed Motor Alarm 2. Feed Motor Run Hold Warning 3. Disc Motor Alarm (LED 1)



A. FEED MOTORS ON/OFF CONTROL & CALIBRATE

The toggle switches positioned on the left hand side of the console operate the feed motors, the central position is off, down to the (I) is on and (C) is to calibrate when in the field relative to forward speed, if fitted with a GPS Speed sensor (optional extra).

B. FEED MOTORS LEFT AND RIGHT CONTROL

The toggle switch is in the central position when in work, each side can be turned ON and OFF independently for border control and short work. In the raised position the left hand side is off, lower position the right hand side is off (remember this is from the driving position of a self-propelled sprayer with the Fan Jets mounted on the front).

C & D FEED MOTORS VARIABLE SPEED CONTROL

The 3 position toggle switch to the left of the centre rotary dial selects the speed range of the feed motors. This switch and the dial are used in combination to select the feed motor speed, and thus the application rate. The 3 position switch selects the speed range, the uppermost position is High Range, middle position is Mid Range, and the lowermost position is Low Range and 12 speeds in each range allows a total of 36 different motor speeds. Use the speed ranges and dial to increase or decrease seeding rate as required.

E. SPINNING DISC CONTROL ON/OFF

Both spinning discs are switched ON or OFF by the toggle switch positioned to the right hand side of the console – both discs start and stop together.

F. SPINNING DISC SPEED CONTROL

The speed of the discs is controlled by the 12 position rotary dial positioned to the right hand side of the console – maximum speed and thus maximum spread width is achieved in position 12, and reducing the disc speed will reduce the spread width – both discs run at the same speed.

12.0 Control System Operation

STANDBY MODE

With both the power and console control cable connected, and all toggle switches in the OFF position, the Fan Jet will be in standby mode, ready for work. The green LED to the right hand side will pulse slowly indicating power connection.

1. Feed Motor Alarm

2. Feed Motor Run Hold Warning

3. Disc Motor Alarm (LED 1)

NOTE: The current consumed when the Fan Jet is in standby is negligible and these cables can remain connected overnight or for many days without the vehicle being used with no problems. However, if the vehicle is not to be used for several weeks, we recommend the power cable is disconnected.



RUN HOLD MODE

Select the required disc speed using the speed dial (F) setting 12 giving the maximum disc speed / spread width.

Select the required feed motor speed and range to give the correct application rate for your forward speed and working width.

Switch the feed motor toggle switch A to ON. The unit is now powered up and enabled.

RUN MODE

Switch the disc ON/OFF toggle switch (E) to ON, both discs will run at the speeds selected. To start product feeding move the toggle switch (A) to start the feed motors, LED 1 status will now be continuous green.

At headlands to turn both the feed motors OFF, switch the feed motor switch (B) to the central position (the discs remain spinning).

The LED status will be slow pulse red and the audible alarm will sound until switched to ON.

To turn the left hand or right hand feed motor ON or OFF for border control or short work, move the toggle switch (B) to the appropriate position, the raised position the left hand side is off, lower position the right hand side is off (remember this is from the driving position of a self-propelled sprayer with the Fan Jets mounted on the front) The LED status will be slow pulse red and the audible alarm will sound until switched to ON.

In work, if either the feed motor speed or the spinning disc speed is altered from the initial settings, the LED status will change to rapid pulse red and rapid audible alarm will sound until the original settings are re-selected.

If the speed change is intended to be permanent for the remainder of the field – briefly switch the discs to OFF for approximately 2 seconds only, until the green LED turns off, then switch the discs back ON and the alarm status should be cancelled and the green LED should be continuous. To stop the Fan Jet – switch the disc ON / OFF toggle switch (E) to the upper position to power down the machine and it will return to standby mode.

13.0 GPS Kit - Optional

Part No. TJ-004-GPS-KIT

For best results and to avoid over applying product, we recommend the machine is fitted with this optional GPS Kit, as this will give speed proportionate metering of pellets, maintaining the pre-set application rate in-line with forward speed changes – if the system is not able to maintain the rate, it will alarm and alert the operator.

⚠ WARNING! This GPS kit must be used as the control system is not designed to work with the signal generated from a standard GPS receiver or Ground Speed Radar.



If the machine is not being used with this GPS speed sensor – this operation will not be necessary as the machines will operate at a fixed output to match a fixed forward speed and this speed must be maintained – this is the speed used in the calculation – it will **NOT** be speed proportionate metering.

NOTE: This calibration can only be done after the application rate has been set. It will not work if it is done prior to calibrating the machine.

This speed calibration is done in the field, on the move at the same speed used in the application rate calculation, and the small white circular GPS receiver mounted on the top of the LHS Fan Jet chassis will register the actual forward speed, and the VS-2 will then match the rate to the speed.

PROCEDURE

1. Set the main power ON/OFF – disc ON/OFF switch (**E**) to the lower ON position.
2. Set the feed motor switch (**A**) to the mid OFF position – not spreading for this calibration.
3. All other switches and dials are positioned where they are following the application rate calibration.
4. Ensure that both green and red LED's are showing on the Black inline Satspeed2 box that is positioned on the rear upright of the LHS chassis – a solid green LED indicates that the GPS receiver has power and a solid red LED indicates it is receiving signals from GPS satellites.
5. Drive forward and accelerate until the “calibrated speed” is reached – indicated using the vehicle speedometer or radar or GPS – this is the speed used during the catch and weigh test – maintain this speed and press and hold upwards the spring loaded toggle switch (**A**) until two solid green LED and one solid red LED appear, and you will hear an audible alarm to indicate that it has calibrated successful.
6. Release the switch, the VS-2 has now registered the signal from the GPS receiver at this speed and now knows that it has to balance the signal from the feed motor (established during the catch and weigh test using this same speed as the target field speed) to the signal from the GPS running at this actual field speed – from now on it will maintain the proportion between the two. If for any reason it cannot do this – an alarm will sound and a red LED will light – for example, this could happen if the feed motor needs to run faster as the forward speed increases, but the motor is at the limit of its performance and cannot increase RPM further. This example is when a change of feed rollers needs to be considered to meter more grams per revolution to allow the motor to run slower for the same application rate.

Once this Speed Calibration is done, your machine is ready for work and will operate at varying forward speeds, maintaining your calibrated application rate. Providing **all LED displays are green** and the alarms silent in normal work – everything will be working correctly. If the feed motor cannot achieve the required speed to maintain the rate, an alarm will sound and a red LED will light.

If the application rate or disc speed is changed whilst on the move by increasing or decreasing the feed or disc motor speeds using the appropriate dials – a rapid pulsed red LED will light and the alarm will sound to remind you that the original settings are changed and will remain on until they have been returned to the original setting.

Turn the feed motors ON and OFF as required using toggle switch (**A**) using only the mid to low position – not the spring loaded upper position. This will start and stop both Fan Jets together unless you have chosen to switch off one side or the other using the independent LHS/RHS feed control switch.

If a new product calibration or target field speed is needed, then this speed calibration will need to be repeated.

NOTE: When calibrating for a new application rate, or a new forward field speed – first disconnect the main power cable to the Fan Jet for at least 10 seconds – this will cancel the memory of previous calibrations and allow new settings to be used.

14.0 Setting The Feed Rate

The feed rate is adjusted primarily by the motor speed.

In addition, different feed rollers may be fitted that deliver different rates of material per revolution. Refer to the Calibration Procedure and with the appropriate feed rollers fitted, follow the instructions. You may have to change the feed rollers to obtain the application rate within a sensible forward speed range which is calculated during the calibration procedure.

STANDARD 8 SECTION FEED ROLLS - Wide 8 section rolls for high rate application and large granules.

The two feed rollers fitted should allow for typical slug pellets application rates.

There are extra feed rollers supplied in the kit and appropriate spacers to allow 1, 2 or 3 feed rollers to be fitted to each feed block to help obtain the correct feed rate required for lower or higher outputs and varying speeds. **Optional feed rollers are available, for more information please contact your local Stocks Ag dealer.**

⚠ WARNING! Always observe all application standards and guidelines provided by the product manufacturer as some products may be toxic ! If unsure contact your supplier for more information.

14.1 Changing The Feed Rollers

The feed rollers are easily changed by removing the feed block assembly as follows.

NOTE: Empty the hopper completely before doing this using the tipping facility.

- Undo and remove the 2 black plastic retaining knobs holding the feed block in place.
- Slide the complete mechanism out.
- Undo and remove the 4 socket head screws on the end of the housing opposite the retaining plate and remove the end plate.
- Slide the rolls and spacers off the shaft, and replace with the alternative rolls and spacers in the required combination.
- Refit the end plates and re-fit the feed block and black plastic retaining knobs.

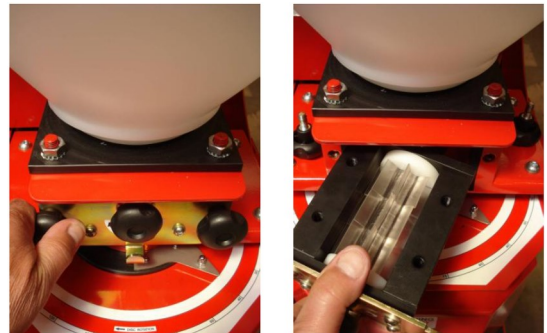

14.2 Feed Roller Configuration

1 x 8 Section Feed Rollers

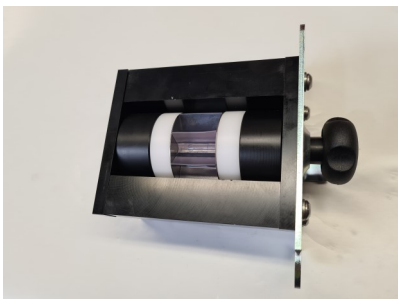

2 x 8 Section Feed Rollers

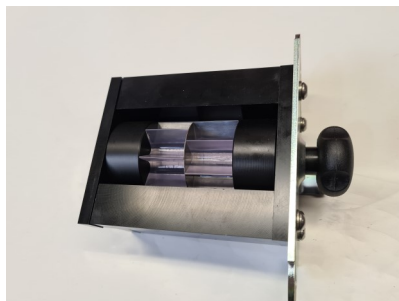

3 x 8 Section Feed Rollers

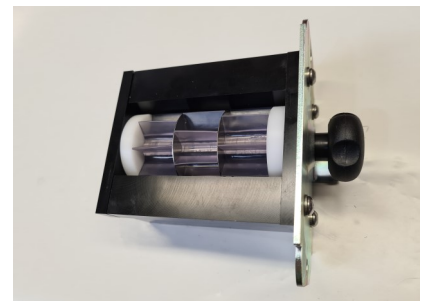

When re-fitting the end plates to the feed block after changing the configuration, the end plate should be able to fit flush with the feed block by hand, without having to pull it home with the socket head screws.

NOTE: You should be able to rotate the feed shaft with your fingers – if it feels excessively tight, check the feed roller and spacer composition is correct as shown above or call Stocks Ag for advice.

15.0 Calibration Hopper

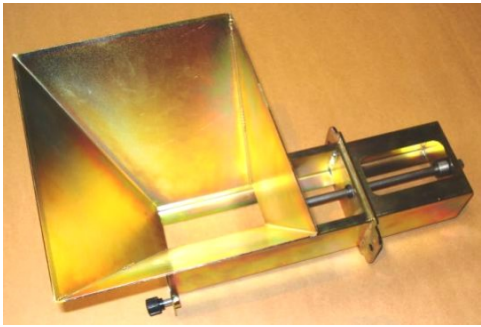

Supplied as standard with the machine (packed in hopper).

Part No. FJ-005-CAL-DUO

15.1 Fitting Instructions

1. With an empty hopper, remove the feed block assembly from one of the Fan Jets.



2. Slide the Calibration Hopper into the Fan Jet in place of the feed block with the hopper uppermost, ensure the drive shaft aligns and secure with the supplied screw knobs.



3. Insert the (removed) feed block into the Calibration Hopper, ensure the drive shaft aligns by slowly rotating the feed shaft.

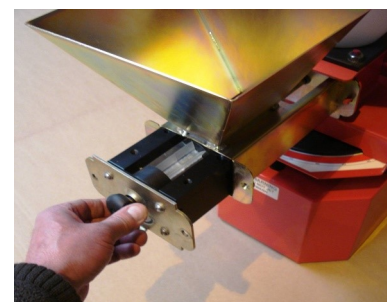

4. Secure with the two small black PVC knobs supplied.



5. Place a suitable container under the Calibration Hopper to collect pellets whilst calibrating.

16.0 Control Panel Calibration



Working from the left hand side.

1. Set the **feed motor ON/OFF toggle switch** to the **lower ON (I) position**.
2. Set the **LHS/RHS feed motor toggle switch** to the **lower RHS OFF position**.

NOTE: Remember to set this switch to the mid position after calibration to turn both feed motors ON for in field work.

3. Set the **feed motor speed range toggle switch** to **mid (Mid Range) position** (if the initial calibration).
4. Set the **feed motor speed rotary dial** to **position 6** (= mid speed setting 18 of 36 if the initial calibration).
5. Set the **main power ON/OFF – disc ON/OFF toggle switch** to **upper OFF position**.
6. Set the **disc speed rotary dial** to **position 1** – this sets the system in calibrate mode, ready for the catch and weigh test (as below).

NOTE: remember to increase this disc speed after calibration towards position 12, when spreading in the field – check spread the spread width is satisfactory.

16.1 Calibrate Switch

Hold down the spring loaded switch mounted on the lower rear of the LHS Fan Jet chassis for a couple of seconds – “HOLD DOWN SWITCH TO CALIBRATE” – the LHS feed motor should start to rotate and turn the feed block in the calibration chute as long as the switch is held down – check this works correctly – release the switch to stop the motor.



NOTE: The discs should not be turning and the RHS feed motor should not turn.

NOTE: The RHS Fan Jet can be calibrated if desired by setting the LHS/RHS feed motor toggle switch to the upper LHS OFF position, and repeat holding down the spring loaded calibrate switch – this time only the RHS feed motor should turn.

Generally it is not required to do this as both Fan Jets will meter the same amount of product provided they are fitted with the same feed rolls – so calibrating just one Fan Jet (the LHS normally) for full rate at half width and ensuring the other has the same feed rolls should be satisfactory.

16.2 Spread Bias Adjustment

Ensure the correct Fan Jets are fitted in the correct position – the fixed deflectors fitted to the side of the Fan Jet chassis should be facing inwards towards each other.

Ensure the disc rotation is correct. When viewed from behind, the left hand side Fan Jet disc should rotate in a clockwise direction and the right hand side Fan Jet disc should rotate in an anti-clockwise direction, for clarification see Disc Rotation arrows on the decal.

The position of where the pellets flow onto the disc will affect where they come off the disc – this will affect the overall spread width and pattern. Adjustment is provided by rotating the bias dial * factory set at 65 degrees.



The black plastic knob on the side of the chassis secures the bias adjustment. Unscrew prior to adjustment and then retighten.

For maximum spread width, ensure disc speed is 100%. Bias adjustment will alter spread width pattern (most standard pellets 60–75 degree). Check overlap between wheels and extreme, adjust accordingly.



Ensure the two spread patterns from the left hand and right hand machine meet and overlap in the middle and the overall spread width is correct.

17.0 Spread Width and Pattern

Basic Rule: The spread width is dependent upon the density of the granule or seed, and the disc speed (plus other factors).

Large, dense granules and seeds with a high disc speed give the maximum spread width – small, light granules and seeds will not spread as far.

Other factors affect the spread width:

Type of slug pellet. Typically, a large, dense hard pellet should spread further than a small, light, soft pellet, because it is comparatively heavy and does not powder on the disc. Typically, a 'wet' produced pellet will be hardest, a steam produced pellet mid range, and a dry produced pellet the softest. However, the line between traditional 'mini' pellets and 'full size' is blurred as most are of similar size and some lower priced dry produced pellets termed, as 'minis' are actually larger and heavier than more expensive wet produced pellets, and can have a good spreading characteristics.

Seed varieties and dressings. Different varieties of seeds and seed dressings will have different densities and so affect the maximum spread width possible.

Wind Conditions. Dead calm conditions are the optimum: any wind will affect the width pattern.

High forward speed. The same as driving into a headwind of the same speed on a calm day, this will peel the edges of the spread pattern backwards and inwards.

Disc speed. If the Vario control console is used, altering the disc speed will affect the width and pattern. A higher disc speed will give a wider spread width.

Disc vanes. Ensure they are in good condition and not worn excessively. Replace if necessary.

Part No. FJ009C includes 2 vanes and fixings (**available through your local dealer**).

Low disc height. Will not allow the product to reach its maximum width before gravity takes over.

Low electrical power. Will not allow the disc to reach full speed.

High application rates. Loads the disc more than a lighter rate and can slow it down.

Incorrect disc angle. It must be at least horizontal – not angled downwards.

Spread bias. This can be adjusted to centralise the pattern, left and right of centreline.

Adjustable deflectors. We do not recommend that these are used for in-field work but only for the headland control on the outside bouts.

However it is possible to adjust them to restrict the width overall or just one side, but they may cause increased breakage of the granules or seed damage.

Our advice would be to use them in conjunction with the Vario control panel where this is used to reduce the disc speed and the deflectors positioned to help limit the spread width.

18.0 Product Calibration

The Fan Jet Duo comprises of two separate machines, each machine left hand and right hand are calibrated as an individual machines. When setting the application rate (kgs/ha) and spread width. The combined overall rate and spread width of both machines should equal the total required.

Use the following formula for all products and where possible always use the estimated in field speed in the equation and when in the field. This will establish how much product will need to be collected in the calibration tray during a 1 minute catch test.

To establish the correct flow rate of pellets for your bout width, forward speed and application rate use the below formula:

Method

Use the following formula to establish the flow rate – this is a 1 minute catch test universal for all machines, products, widths and speeds.

$$\frac{\text{Application rate (kgs/ha)} \times \text{forward speed (kph)} \times \text{spread width (metres)}}{600} = \text{Flow rate in kgs per min}$$

Example 1.

The required application rate is 25 kilograms per hectare. The target forward speed is 10 kilometres per hour. The bout width is 6 metres wide.

$$\frac{25 \text{ kgs/ha} \times 10 \text{ kph} \times 6 \text{ metres}}{600} = 2.5 \text{ kgs per minute flow rate}$$

Example 2.

The required application rate is 5.5 kilograms per hectare. The target forward speed is 12 kilometres per hour. The bout width is 4.25 metres wide.

$$\frac{5.5 \text{ kgs/ha} \times 12 \text{ kph} \times 4.25 \text{ metres}}{600} = 467 \text{ grams per minute flow rate}$$

The flow rate required is the combined output of both machines.

NOTE: Machines are supplied from factory with two feed rollers fitted in each feed block assembly.

This combination suits most 24m to 36m slug pellet applications.

If lower rates are required, then 1 feed roller per feed block assembly can be fitted.

For higher rates, or if traveling at high speeds such as UTV work, the extra feed rollers supplied can be fitted to give 3 feed rollers in each.

19.0 Calibration Catch and Weigh Test

NOTE: To ensure the maximum spread width is obtained, large hard dense slug pellet must be used.

Ensure the two spread patterns meet and just overlap in the centre and reach out each side of centre to give the required total width.

Some smaller, lighter and less dense pellets may not reach the full width especially in breezy conditions and with many pellets, the pattern may be thinner towards the outer edges. Ensure conditions are good and the discs are a minimum of 2 meters above the ground or crop canopy for 36m work. Ensure the spread width and pattern is adequate for your requirements before going to work.

You will have to perform a catch and weigh test to establish the flow rate of product and will need a suitable container to collect the product being metered, an accurate set of scales to weigh kilograms / grams, and a timer.

We recommend using the supplied calibration hopper with the spinning disc turned OFF and control the feed motor with the remote calibration switch.

At this stage only put a small amount of product in the calibration chute - do not fill in case the feed rolls have to be changed to achieve the rate (kgs/min) When you are ready to begin, use the spring loaded Calibrate Switch to start and stop the feed motor.

1. Run the feed motor for the required time.
2. Weigh the collected amount in kilograms.
3. Refer to the calculated amount for your rate/width/speed required.
4. Use the High, Mid or Low speed range, and the speed dial to increase or decrease the rate accordingly and repeat the procedure until the correct output for your machine width and forward speed is reached.

NOTE: Make a note of settings for future reference.

5. Change the feed roll configuration if required to achieve the application rate in the mid range motor speed if possible - rather than running very slow or fast – this allows a greater chance of the rate being changed to match. Increase or decreases in forward speed in the field.

If you do not run the catch test for 1 minute – for example only 30 seconds – then you only need to collect half the amount indicated in the calibration formula.

19.1 Feed Motor Settings and Speeds (RPM)

LOW RANGE		MID RANGE		HIGH RANGE	
Settings 1 - 12		Settings 13 -24		Settings 25-36	
Dial setting	Speed RPM	Dial setting	Speed RPM	Dial setting	Speed RPM
1	6	1 (13)	24.48	1 (25)	42.96
2	7.54	2 (14)	26.02	2 (26)	44.5
3	9.08	3 (15)	27.56	3 (27)	46.04
4	10.62	4 (16)	29.1	4 (28)	47.58
5	12.16	5 (17)	30.64	5 (29)	49.12
6	13.7	6 (18)	32.18	6 (30)	50.66
7	15.24	7 (19)	33.72	7 (31)	52.2
8	16.78	8 (20)	35.26	8 (32)	53.74
9	18.32	9 (21)	36.8	9 (33)	55.28
10	19.86	10 (22)	38.34	10 (34)	56.82
11	21.4	11 (23)	39.88	11 (35)	58.36
12	22.94	12 (24)	41.42	12 (36)	59.9

20.0 Fan Jet Duo VS-2 Parts Diagram

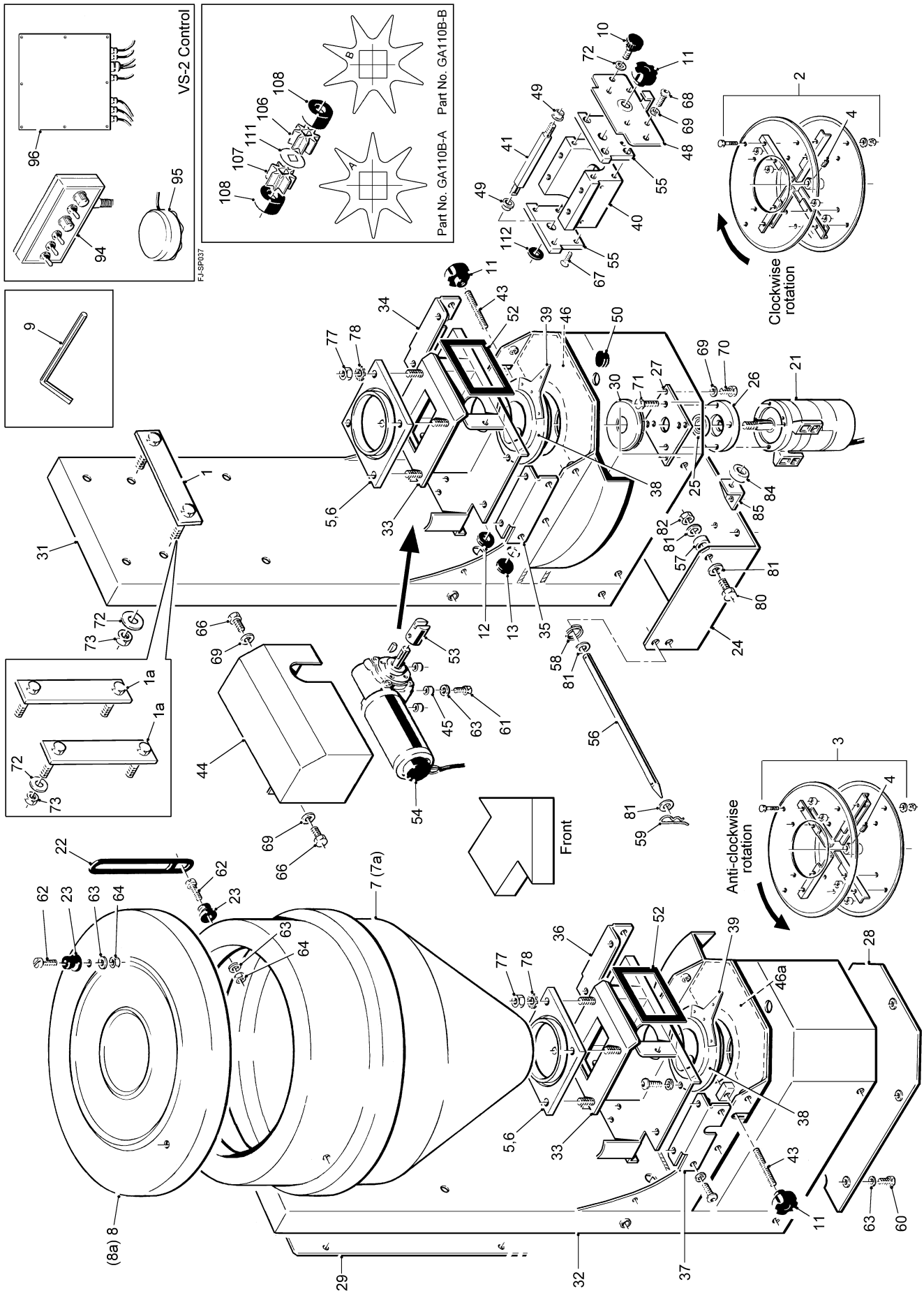

20.1 Fan Jet Duo VS-2 Parts List

Item	Part #	Description	Qty	Remarks
1	FJ003A	Hopper Bracket	2	65L only
1a	FJ005A	Hopper Bracket	4	130L only
2	FJ007E	Clockwise Disc Assembly	1	
3	FJ007G	Anti-clockwise Disc Assembly	1	
4	FJ008A	M6x6mm Grub Screw	2	
5	FJ017D	Hopper Base Plate	2	
6	FJ017S	Base Plate Seal	2	
7	FJ026A-Ass.	65 Litre Hopper Assembly	2	
7a	FJ026B-Ass.	130 Litre Hopper Assembly	2	
8	FJ027A-Ass.	65 Litre Hopper Lid Assembly	2	
8a	FJ027B-Ass.	130 Litre Hopper Lid Assembly	2	
9	FJ028A	3mm Allen Key	1	
10	FJ032B	Male Knob	4	
11	FJ033A	M8 Female Knob	4	
12	FJ039A	Rubber Grommet	4	
13	FJ039B	Blank Rubber Grommet	2	
14	MD005	Decal "FAN JET"	2	(not shown)
15	MD007	Decal "DUO"	2	(not shown)
16	MD042	Decal "Warning" Keep Clear - Wear PPE	2	(not shown)
17	MD052	Decal "Warning" Thrown or Flying objects	2	(not shown)
18	MD002	Decal "STOCKS AG"	2	(not shown)
21	FJ058A-DUO	Disc Motor	2	
22	FJ103A-1	Rubber Tensioner	4	
23	FJ104A-1	Bobbin	8	
24	FJ718A	Tipping Bracket	2	Optional
25	FJ070A	Oil Seal	2	
26	FJ071A	Oil Seal Housing	2	
27	FJ605A	Motor Mounting Plate	2	
28	FJ614A	Base Cover Plate	2	
29	FJ717A	Back Cover Plate	2	
30	FJ707A	PVC Motor Protector Plate	2	
31	FJ700A	Clockwise Chassis (A)	1	
32	FJ700B	Anti-clockwise Chassis (B)	1	
33	FJ720A-Ass.	Metering Block Housing	1	
34	FJ722A	Right Hand Fixing Bracket	1	
35	FJ721A	Left Hand Fixing Bracket	1	
36	FJ721A	Right Hand Fixing Bracket	1	
37	FJ722A	Left Hand Fixing Bracket	1	
38	FJ733A	Rotary Feed Outlet	2	
39	FJ731A	Pointer	2	
40	GA108	Feed Block	2	

20.2 Fan Jet Duo Plus Parts List Continued

Item	Part #	Description	Qty	Remarks
41	GA113D	Metering Shaft	2	
43	FJ732A	M8 Threaded Rod	2	
44	FJ730A	Motor Guard	2	
45	TJ042A	Motor Spacer	8	
46	FJ119A	Decal (clockwise)	1	
46a	FJ119B	Decal (anti-clockwise)	1	
48	FJ540B	Metering Block Mounting Plate	2	
49	GA103	PVC Bush	4	
50	GR002	Blanking Grommet	2	
52	TJ040	Feed Block Seal	2	
53	TJ043A	Coupler	2	
54	TJ044B	Metering Motor	2	
55	GA109	Feed Block End Plate	4	
56	FJ415A	Tipping Plate Pin	1	
57	FJ417A	Nylon Spacer	4	
58	FJ418A	Split Ring	2	
59	FJ419A	Ø3 'R' Pin	2	
60	M5-006	M5x12 Set Screw	10	
61	M5-011	M5 Set Screw	8	
62	M5-012	M5x25 Slot Head CSK Screw	8	
63	M5-014	M5 Flat Washer	18	
64	M5-017	M5 Nyloc Nut	8	
66	M6-004	M6x16 Set Screw	4	
67	M6-007	M6x20 CSK Set Screw	8	
68	M6-008	M6x25 Button Head Set Screw	8	
69	M6-016	M6 Flat Washer	16	
70	M6-002	M6x12 Set Screw	8	
71	M6-007	M6x20 Set Screw	8	
72	M8-012	M8 Repair Washer	8	
73	M8-017	M8 Nyloc Nut	4	
77	M10-023	M10 Nut	8	
78	M10-026	M10 Star Washer	4	
80	M12-004	M12x35 Set Screw	4	

20.3 Fan Jet Duo Plus Parts List Continued

Item	Part #	Description	Qty	Remarks
81	M12-008	M12 Flat Washer	12	
82	M12-014	M12 Nyloc Nut	4	
83				
84	MM569	Rubber Stop	4	Optional
85	FJ719A	Stop Bracket	4	Optional
86				
88	TJ286	4m Control Cable	1	
89				
90	TJ288	6m Control Extension Cable	1	Optional
91				
92				
93				
94	FJ144B	Cab Control Box	1	
95	TJ256	GPS Receiver—Satspeed	1	Optional
96	FJ142B	Junction Box	2	
97				
98	FJ055A	Calibration Toggle Switch	1	(not shown)
99	FJ056C	Toggle Switch Cover	1	(not shown)
100				
101	MD052	Warning Decal - Keep Clear - PPE		(not shown)
102				
103				
104				
105				
106	GA110B-A	Grass Seed Roll	4	
107	GA110B-B	Grass Seed Roll	2	
108	TJ208	10mm Spacer	4	
109	GA114	24mm Blanking Spacer	4	(not shown)
110	TJ204	13.5mm Blanking Spacer	4	(not shown)
111	TJ199	Stainless Steel Shim	1	
112	TJ033	Feed Block Gasket	1	

