



StocksAG

Turbo Jet 8 and 10 Jackal

ORIGINAL OPERATING MANUAL AND PARTS LIST



Read carefully before installation and operation

This document must not be copied duplicated or distributed without prior consent.
All intellectual property and patent rights apply.



Stocks Ag Limited.

Cromwell Road, Wisbech, Cambridgeshire, PE14 0SD, UK
01945 464909 sales@stocks-ag.co.uk www.stocks-ag.co.uk



Index

Section		Page
	E.C. DECLARATION OF CONFORMITY	5
	UKCA. DECLARATION OF CONFORMITY	6
1.0	General Information	7
1.1	Technical Data	7
1.2	Intended Use	7
1.3	Unintended Use	7
1.4	Machine Identification	8
1.5	Warranty	8
2.0	Safety	9
2.1	Safety Warning Decals	10
3.0	Emergency Stop Instructions	11
4.0	Storage	11
5.0	PVC Waterproof Covers	11
6.0	Disposal	11
7.0	General Maintenance	12
7.1	Before Use	12
7.2	Daily Checks	12
7.3	After Each Use	12
8.0	Installation Guide	13
8.1	Base Plate	13
8.2	Spreader Plates	14
8.3	Spreader Plate Set Up	14
8.4	C Section Rail	16
8.5	Feed Hose	16
9.0	Machine Components	17
9.1	Feed Motor	17
9.2	Hopper Agitator	17
9.3	12v Fan Unit	17
9.4	Main Power Cable	17
9.5	Instrument Lead	17
10.0	Inspection	18
10.1	Fan Inspection	18
10.2	Feed Block Assembly Inspection	18

Index

Section		Page
10.3	Agitator Shaft Inspection	18
11.0	Hopper Emptying Procedure	19
12.0	Clearing A Feed Hose Blockage	19
13.0	Checking The Feed Motor	19
14.0	Jackal Control System Overview	20
14.1	Jackal Control System Options	20
14.2	Jackal Control System Operation	21
14.3	Machine Junction Box	21
15.0	Electrical Components	22
15.1	Run Hold/Cut Out Switch - Optional	23
15.2	Hopper Level Sensor - Optional	23
15.3	GPS Speed Sensor Kit - Optional	23
15.4	Wiring For Optional Extras	24
16.0	Power Connection	25
16.1	Instrument Button Functions	26
16.2	Initial Instrument Set Up	27
16.3	Run/Hold Automatic Switch	29
17.0	First / New Product Calibration	30
17.1	Product Calibration	32
18.0	Spreading / Applying Product	36
19.0	Simulated Speed	38
19.1	Alarms and Trip Functions	39
19.2	Quick Rate and Step Size Adjustment	40
19.3	Flush / Hopper Empty	41
19.4	Diagnostics	41
20.0	Feed Block Kit Information	42
20.1	Large Seed Feed Block Kit	42
20.2	Precision Small Seed Feed Block Kit	43
20.3	Granular Feed Block Kit	44
20.4	Stainless Feed Block Kit	44

Section		Page
21.0	Hopper Baffle Plate	45
22.0	Ready For Work	45
23.0	Hydraulic Fan (Optional) Specification	46
23.1	Hydraulic Fan - Safety	47
23.2	Hydraulic Fan - Fitting Position	47
23.3	Hydraulic Fan - Speed Setting	48
23.4	Hydraulic Fan - Speed Guide	48
23.5	Hydraulic Fan - Speed Display	49
23.6	Hydraulic Fan - Speed Sensor	49
23.7	Hydraulic Fan - Mounting	50
23.8	Hydraulic Fan Speed - Fly Lead Wiring	51
24.0	Turbo Jet Parts (Diagram)	52
24.1	Turbo Jet Parts List	53
25.0	Feed Roller Kit Parts (Diagram)	56
25.1	Feed Roller Kits Parts List	57
26.0	Hydraulic Fan - Parts (Diagram)	59
26.1	Hydraulic Fan - Parts List	59
27.0	Turbo Jet Hydraulic Version - Parts (Diagram)	60
27.1	Turbo Jet Hydraulic Version - Parts List	61

StocksAG**E.C. DECLARATION OF CONFORMITY**

Machine Type: Mounted Agricultural Implement - Pellet and Seed application broadcasters

Model(s):	Fan Jet Pro	All Variants and Versions
	Fan Jet Plus	All Variants and Versions
	Fan Jet Mini	All Variants and Versions
	Fan Jet Duo	All Variants and Versions
	Maxi Jet	All Variants and Versions
	Turbo Jet	All Variants and Versions
	Rotor Meter	All Variants and Versions
	Rotor Jet	All Variants and Versions
	Micro Meter	All Variants and Versions
	Maxi Meter	All Variants and Versions

Serial No.

Manufacturer: Stocks Ag Ltd
Cromwell Road
Wisbech
Cambridgeshire PE14 OSD
United Kingdom

This is to declare that the above machine conforms to the relevant Essential Health and Safety Requirements of the Machinery Directive 2006/42/EC, implemented in the United Kingdom by Statutory Instrument 2008 No. 1597 – The Supply of Machinery (Safety) Regulations 2008 as amended.

The following standards have been applied in the design and construction of this machine:

BS EN ISO 12100:	2010	Safety of machinery – General principles for design – Risk assessment and Risk reduction.
BS EN ISO 4254-1:	2015	Agricultural machinery – Safety - General requirements.
BS EN ISO 4254-8:	2018	Agricultural machinery. Safety - Solid fertiliser distributors.
BS EN ISO 13854:	2019	Safety of machinery – Minimum gaps to avoid crushing of parts of the human body.
BS EN ISO 13857:	2019	Safety of machinery – Safety distances to prevent hazard zones being reached by the upper and lower limbs.

The manufacturer stated above holds the technical file for this machine.

Signed on behalf of Stocks Ag Ltd

Name:  J WoolwayDate: 06th August 2020

Position: Managing Director

t. +44 (0) 1345 464309 f. +44 (0) 1345 464985 e. sales@stocks-ag.co.uk

StocksAG**UKCA. DECLARATION OF CONFORMITY**

Machine Type: Mounted Agricultural Implement - Pellet and Seed application broadcasters

Model(s):	Fan Jet Pro	All Variants and Versions
	Fan Jet Plus	All Variants and Versions
	Fan Jet Mini	All Variants and Versions
	Fan Jet Duo	All Variants and Versions
	Maxi Jet	All Variants and Versions
	Turbo Jet	All Variants and Versions
	Rotor Meter	All Variants and Versions
	Rotor Jet	All Variants and Versions
	Micro Meter	All Variants and Versions
	Maxi Meter	All Variants and Versions

Serial No.

Manufacturer: Stocks Ag Ltd
Cromwell Road
Wisbech
Cambridgeshire PE14 OSD
United Kingdom

This is to declare that the above machine conforms to the relevant Essential Health and Safety Requirements of the Machinery Directive 2006/42/EC, implemented in the United Kingdom by Statutory Instrument 2008 No. 1597 – The Supply of Machinery (Safety) Regulations 2008 as amended.

The following standards have been applied in the design and construction of this machine:

BS EN ISO 12100:	2010	Safety of machinery – General principles for design – Risk assessment and Risk reduction.
BS EN ISO 4254-1:	2015	Agricultural machinery – Safety - General requirements.
BS EN ISO 4254-8:	2018	Agricultural machinery. Safety - Solid fertiliser distributors
BS EN ISO 13854:	2019	Safety of machinery – Minimum gaps to avoid crushing of parts of the human body.
BS EN ISO 13857:	2019	Safety of machinery – Safety distances to prevent hazard zones being reached by the upper and lower limbs.

The manufacturer stated above holds the technical file for this machine.

Signed on behalf of Stocks Ag Ltd

Name:  J WoolwayDate: 01st December 2020

Position: Managing Director

t. +44 (0) 1945 464909 f. +44 (0) 1945 464985 e. sales@stocks-ag.co.uk**UK
CA**

1.0 General Information

Congratulations on your Turbo Jet purchase.

Please check the machine for any transport damage upon receipt and advise your supplier of any problems immediately. Late claims regarding any damage may be rejected.

Specifications, descriptions and illustrations in this manual are accurate at the time of publication but may be subject to change. This manual is correct at the time of printing but Stocks Ag reserve the right to change and improve them. This machine is designed with safety in mind. Maintenance and servicing in accordance with this manual will ensure safe operation and reliability of your machine for many years.

This Operating Manual forms part of the machine and must be readily available for the operator who must read and follow the points covered before use.

1.1 Technical Data

Model: Turbo Jet 8 Jackal and Turbo Jet 10 Jackal

Power requirement: 30 amps

Hopper capacity: 240 litre or 400 litre

Motor output: 360 watt

Max. spreading width: TJ 8: 8m, TJ10: 10m

Noise level: 70dB Electric Fan - 90dB Hydraulic Fan

TJ10: 15m with Hydraulic Fan

Power consumption of the motor: 35 amps when

Rec. working width: TJ 8: 8m, TJ 10: 3-10m

(Depending on application)

starting, up to 30 amps during normal operation

Operating voltage: 12v

240 litre machine:

Net weight: 90kg with spreader kit 120kg

Dimensions: 66 x 100 x 116cm

400 litre machine:

Net weight: 95kg with spreader kit 130kg

Dimensions: 66 x 100 x 143cm

1.2 Intended Use

This Turbo Jet has been designed solely to apply small seed and granular products for use in the agricultural, horticulture and the amenity sector.

Any other use is considered to be non-intended and the manufacturer will not be liable for any resulting damage.

The manufacturer is not liable for any resulting damage if the machine is used for any other purpose than the intended use and also includes compliance with the conditions for operation, maintenance and repairs prescribed within this instruction manual.

NOTE: Do not use this machine during adverse weather conditions.

The applicable accident prevention regulations as well as the other generally safety-related, occupational health and road traffic regulations must also be observed.

1.3 Unintended Use

This machine is not designed to apply abrasive materials such as sand and grit or for applying salt products.

The operator alone bears the associated risk if used for non-intended use.

1.4 Machine Identification

Example Decal Only



The machine can be identified by the serial number decal mounted on the steel chassis to the left of the feed cassette.

1.5 Warranty

We provide a 12 month warranty from the date of invoice (the invoice for the machine will serve as a warranty certificate).

This warranty is applicable for cases of material or construction faults and does not include parts that are damaged by normal or excessive wear.

Warranty expires if damage is caused by external forces, operator error, modifications, jet washing or if the machine has been used for unintended use.

In the event of any problems, or before attempting any repair, please contact the company from where the machine was purchased. If the base machine or the controls system are modified in any way this will void any warranty claim.

Stocks Ag cannot be held responsible for any claims or injuries to the owner or any third parties while in the operation of Stocks Ag equipment.

On no account can Stocks Ag be held liable for accidental or consequential damages (including loss on anticipated profits) for any impairment due to failure or defect of the machine.

Please see our conditions of sale for full details, a copy of which available upon request.

Please record the machine serial number here: S/N

Purchase date Dealer

2.0 Safety

Ensure care is taken when lifting the machine. Safe lifting practice to be observed when handling as the net weight is over 25kg.



- We advise safety shoes and protective gloves are worn when handling the machine.
- Assistance will be required when lifting or lowering the machine.
- Care to be taken to avoid crushing due to the weight of the machine.
- When lifting or fitting the machine on to a parent vehicle or implement ensure work is performed on level ground or flat surface to avoid slipping, stumbling or falling.

PERSONAL PROTECTION EQUIPMENT

It is the responsibility of the operator or maintenance engineer to ensure safe handling of the machine and the appropriate personal protection equipment must be worn for the material being applied and to prevent contamination to the machine or the environment.

⚠ WARNING! Ear protection required if working in close proximity to the machine as it exceeds 70dB.

PRODUCT APPLIED

If applying slug pellets or other toxic material and the parent vehicle has a closed cab the operator must ensure the cabin is always closed and the air filter system is in good order. If fitted to a UTV vehicle ensure the stability of the parent vehicle is not affected when the machine is in use. If in doubt contact the vehicle manufacturer for more information. After working the machine ensure that any unused product is returned safely to its original packaging. Stocks Ag Ltd. does not accept any liability for the storage and use of the material being applied.

NOTE: If unsure contact your seed or product supplier for more information.

⚠ WARNING! Always observe all application standards and guidelines provided by the product manufacturer as some seed dressings and granular products may be toxic.

OPERATION AND MAINTENANCE

The machine may only be used, maintained and repaired by persons who have relevant experience or a machinery dealer who is aware of any risks involved. The applicable accident prevention regulations as well as the other generally safety related, occupational health and road traffic regulations must also be observed.

The manufacturer is not liable for any damage resulting from unauthorised modifications and the use of components and auxiliary parts. The machine must be checked regularly by the operator (before each use) for any damage, loose bolts or electrical connections, vibrations, unusual sounds and to ensure it functions correctly.

The machine must not be operated in wet weather conditions or during thunderstorms. Observe the generally applicable safety and accident prevention regulations. Always empty the hopper of toxic materials to prevent harm to humans and animals after each use and prior to storage.

⚠ WARNING! Do not put your hands inside the hopper when the agitator motor is turning as the agitator shaft inside the hopper rotates at high speed and is sharp and dangerous.

⚠ WARNING! Always isolate the power supply if servicing or leaving the machine unattended.

2.1 Safety Warning Decals

Important: Be aware of the safety warning below which are all relevant to this machine.



⚠ WARNING!

Read and understand the Operators Manual instructions before operating this machine.

Operator errors can result in serious injury.



⚠ WARNING!

Danger due to thrown or flying objects.

Always maintain a safe distance whilst the machine is in operation.



⚠ WARNING!

Risk of injury. Possible trapping point when tipping hopper.



⚠ WARNING!

Risk of injury.

Be aware the feed mechanism is powerful and can cause serious injury.



⚠ WARNING!

Keep Clear!

Maintain a safe distance from the machine when in operation.

Wear the appropriate protective personal equipment.



⚠ WARNING!

Do Not Jet Wash. This machine is not designed to withstand jet washing.

3.0 Emergency Stop Instructions

In the case of an emergency always switch off the main power switch on the control panel and isolate the power supply immediately by disconnecting the power cable.

1. Power down the control system immediately by switching the main power switch to the middle setting marked "O" on the cab mounted control panel.
2. Disconnect the power supply by unplugging the power cable or removing the fuse.

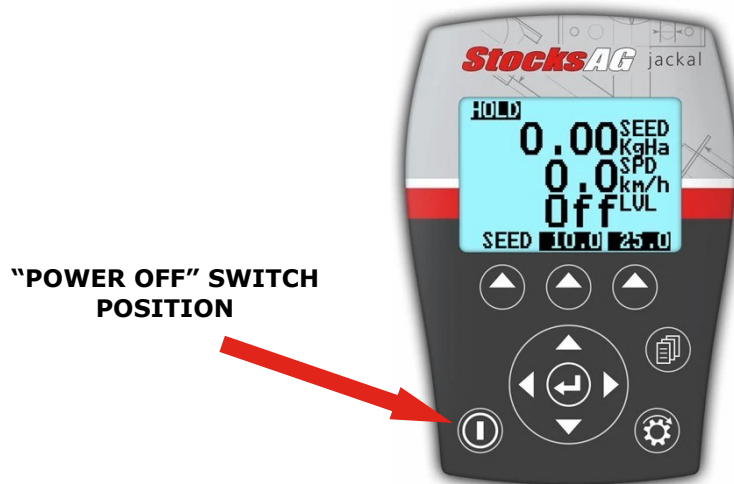

4.0 Storage

Disconnect the power supply by unplugging the power cable or by removing the fuse fitted in the power cable.

It is the responsibility of the operator to ensure the hopper is empty after use and cleaned thoroughly before storage.

Store in dry conditions to protect the machine and control system from moisture.

Always clean and spray electrical connectors with a moisture repellent spray when not in use for long periods.

Fit the PVC waterproof cover (if available).

Ensure feed blocks are free to turn and all electrical cables checked following periods of storage.

5.0 PVC Waterproof Covers - Optional

240L Waterproof PVC Cover Part No. TJ240COVER

400L Waterproof PVC Cover Part No. TJ400COVER

Heavy Duty white PVC covers fitted with eyelets and bungee cord for easy attachment.

Please contact your local Stocks Ag dealer for more information.

6.0 Disposal

Ensure that any persons handling the machine are aware that the machine may have been used to apply toxic chemicals and so the appropriate personal protection equipment should be worn.

Ensure the hopper contents have been removed and any toxic residue removed and put back into a sealed container or disposed of in accordance with the manufacturers guidelines to eliminate any possible contamination of others or the environment.

Always adhere to the local disposal regulations paying particular attention to the plastics, rubber, and electrical components.

7.0 General Maintenance

Ensure the parent machine is stationary and parked on level ground before working on the machine.

The machine must be checked regularly by the operator for any damage, loose bolts or electrical connections, vibrations, unusual sounds and to ensure it functions correctly.

⚠ WARNING! Always ensure the power supply is disconnected before any maintenance work or cleaning of the machine by unplugging the power cable or removing the fuse in the power cable.

Always observe all guidelines provided by the product manufacturer with regards to handling, storage and disposal of products.

Take care not to spill any product that could contaminate the machine or the environment, ensuring any product removed from the machine is put back into its original container.

⚠ WARNING! Protective clothing must be worn when applying or handling toxic products.

7.1 Before Use

1. Ensure the machine is securely mounted.
2. Check the power supply and ensure the power cable is connected directly to the vehicle battery.
3. Check the feed block is configured correctly and free running before starting work.

7.2 Daily Checks

1. Check the feed motor and agitator motors are working correctly.
2. Check the 12v fan and air intake meshes are clean and free from any debris.
3. Check feed hoses for any blockages and all hose clips are tight.
4. Check the spreader plates are positioned correctly.

7.3 After Each Use

1. Empty hopper and clean the machine thoroughly.
2. Disconnect the power supply.
3. Replace the PVC waterproof cover (if applicable).
4. Store in dry conditions to protect the machine and control system from moisture.

⚠ WARNING!
DO NOT JET WASH THIS MACHINE.



8.0 Installation Guide

The Turbo Jet can be used for a wide variety of seeding applications in conjunction with a wide variety of parent implements.

It is not practical to supply tailored mounting brackets for every implement on the market, and so the final attachment of the Turbo Jet to the implement is the responsibility of the supplying dealer or end user.

The positioning of the hopper, the spreader plate, and "C" section mounting rails, if used, will depend upon the type and design of host implement. Here are a few basic pointers to ensure the Turbo Jet performs correctly.

Position the Turbo Jet high enough above the implement to facilitate routing of the flexible tubes, to the spreader plates, without severe bends or uphill runs. Try to route all tubes generally downhill. Do not block the air intakes to the fans under the base plate.

If mounting on a folding implement, ensure the wing sections do not foul the hopper and all hose runs are long enough to fold with the implement.

Ensure you can access the hopper to fill, and are able to remove the feed block assembly and position the calibration tray underneath to calibrate or empty.

Ensure there is room to undo the fan housing catches and lift the housing to clean the fans. When filling, emptying or calibrating the Turbo Jet ensure you work safely. If necessary fabricate and fit a work platform and steps, complete with handrails. The hopper may face forwards or backwards, whichever offers the easiest mounting and best flexible hose run. Select a strong, rigid position and use the heavy flat base plate provided to weld or bolt to your implement as per the below example.



8.1 Base Plate

Part No. TJ422 Dimensions and fixing hole detail.

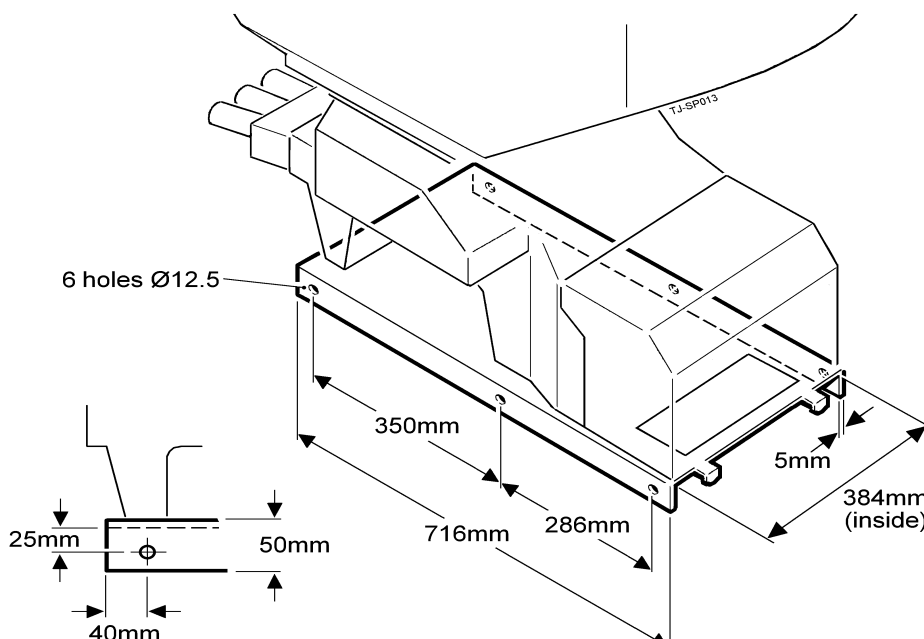

8.2 Spreader Plates

The machines have 8 or 10 outlets, if required the feed hoses can be split with the black "Y" connectors in the relevant kits, to give 16 or 20 spreader plates. Depending on the implement width and if you require a broadcast or band sown effect, use as many outlets as required.

Plan the positioning of the pipes/spreader plates to be equal distant across the width of your implement. If using the black plastic "Y" connectors ensure they are fitted above the spreader plate using as short a run of flexible hose to the plates as possible, whilst still providing a smooth flow and of being equal length. It is recommended that a straight of a minimum 300mm section of pipe is utilised prior to the "Y" connector, to ensure a more even split of product. Flexible hoses from these connectors then runs to the outlet pipes on the Turbo Jet. Aim to route all these hoses smoothly and generally downhill from the hopper to the spreader plate, avoiding severe bends and uphill runs.

8.3 Spreader Plate Set Up

The Stocks Ag spreader plate was developed to allow a wider spread pattern while positioning the outlets closer to the ground.

For products such as grass seed, oil seed rape and Avadex, a spread width per outlet of 750mm is achievable from as low as 250mm above the ground (250mm to the bottom plate).

A 6m grass harrow only requires 8 evenly spaced outlets. In many circumstances reducing the need for Y piece splitters and having double the outlets.

The spreader plates have two main adjustments to set up the optimum spread pattern to suit a variety of products and machine fitments.

The main bottom plate requires bending into position. The angle of the bottom plate alters the spread width from each outlet. A common setup would be to bend from vertical to approximately 15° from parallel to the top plate (see below).

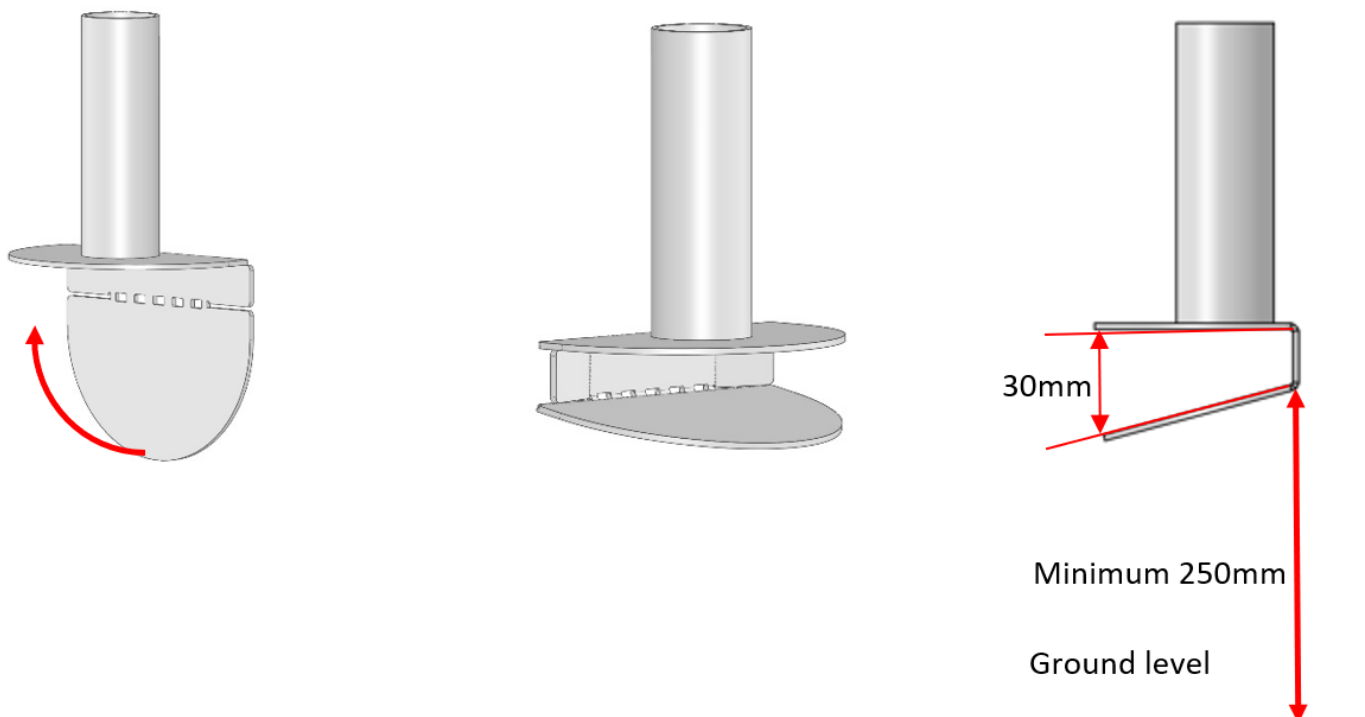

8.3 Spreader Plate Set Up—continued

There are two adjustable tabs on the back plate of each outlet. These tabs are used to create an even arc shaped spread pattern and when required, to adjust overlap between outlets.

When the back plate is left straight, some products can produce a spread pattern similar to the diagram below.

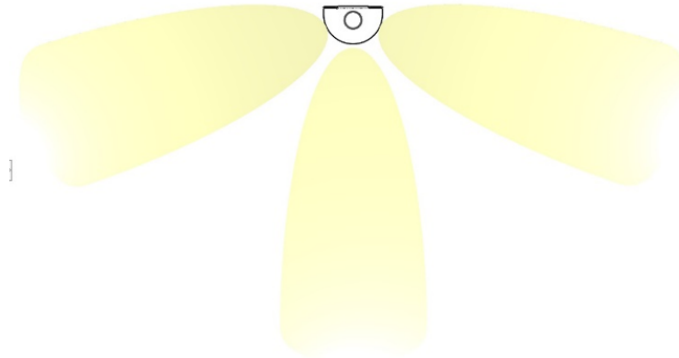

By bending the back plate tabs in slightly (see diagram below).

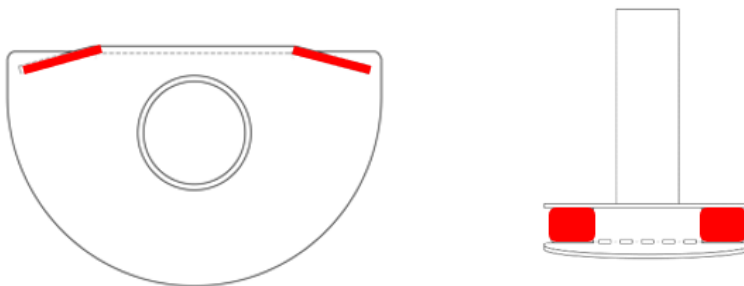

The coverage of product over the ground can be made much more uniform.



These recommended settings are an initial guide, set up may vary between different products and machine fitments, that require further adjustment.

8.4 C Section Rail

The spreader plates themselves are mounted to the "C" section rails, these can be ordered in 2m lengths as an option. Part no. **47TJT5008**. These can be cut down to suit the implement width. The "C" section rails can be attached to the implement using the supplied straight brackets, two per rail, which can be welded or bolted into position.

The spreader plates slide along the rails to give the planned spacing and lock into position using the integral bolts. It is generally better to position the spreader plates facing to the rear of the implement as this can prevent wet mud or tilth being thrown up into the mouth of the spreader causing blockages, especially if positioned close behind the tractor wheels, roller or discs.

8.5 Feed Hose

The feed hose comes in coils 30m long, to be ordered as an option with a new machine. Extra rolls can be ordered as a spare part, **part no TJ222-30M**. This requires cutting into lengths according to the positioning of the hopper and spreader. Ensure all hose runs are as short as possible whilst giving a smooth downhill route to the spreader plates. Avoid kinks, severe bends or uphill runs. Plan and measure the individual hose runs before cutting, fit the hose clips to the "Y" connector tails.



9.0 Machine Components

9.1 Feed Motor

The feed motor can be turned ON or OFF, either manually via the head unit, or automatically using the linkage position sensor through the 7 pin plug. Alternatively, through an optional remote mounted spring type finger switch, which can be fitted to the linkage or the implement.

9.2 Hopper Agitator

The internal agitator is powered independently by a separate motor. Its purpose is to prevent seed becoming compacted in the hopper and bridging (not flowing). It is recommend for all grass and grass seed mixes, or other seed that may bridge in the hopper, but it is not required for free flowing seeds such as OSR, clover, stubble turnips or similar, or granular products.

NOTE: If using the agitator in the field, also have it turned on for calibration.

9.3 12v Fan Unit

The double 12v fan unit is housed under the hinged meshed cover designed for easy access. Air is drawn through the mesh intakes on the rear, front and sides of the cover and underside the mounting base plate. This hinged cover can be lifted for cleaning purposes.

9.4 Main Power Cable

The heavy duty power cable must be connected directly to the vehicle battery posts to ensure adequate 12v supply and is fitted with a 40 amp fuse to protect the control system.

This cable should be long enough to give a break point at the rear of the tractor so that the 5m power extension cable, also supplied, (and any additional extension cable needed), can then be connected to the power input flylead on the machine.

9.5 Instrument Lead

The 5m instrument lead connects to the junction box of the Turbo Jet and runs to the control panel in the tractor cab.

Ensure the multi pin connector on the instrument cables are connected the correct way around as shown.

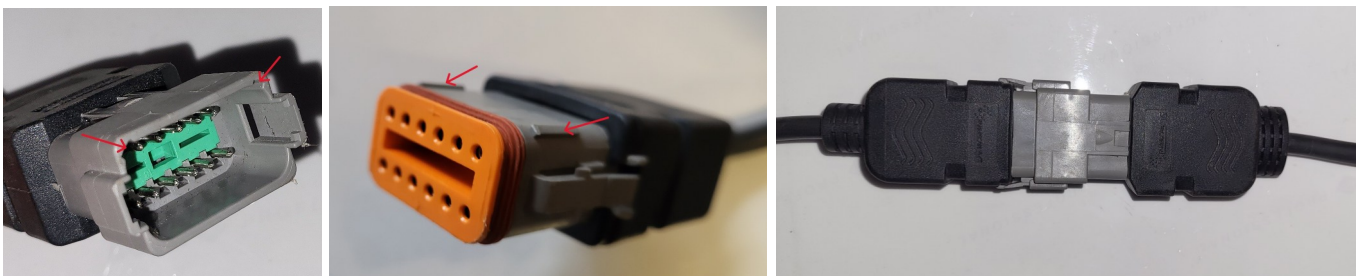

NOTE: Extension power and instrument cables available if required.

Please contact your local Stocks Ag dealer for more information.

10.0 Inspection

10.1 12v Fan Inspection

⚠ WARNING! Always isolate the power before inspecting or servicing the machine.

To inspect the fan unit undo the two over-centre catches and hinge up the guard as shown below. Wearing appropriate PPE, use an air line and brush to clean the fan blades regularly to maintain performance and prevent eccentric running.

Always check the fan air intakes are clean and free from debris.



10.2 Feed Block Assembly Inspection

⚠ WARNING! Always observe all application standards and guidelines provided by the product manufacturer as some seed dressings and granular products may be toxic!

NOTE: If unsure contact your seed or product supplier for more information.

1. Empty the hopper completely to prevent spillage, release the two over-centre catches and drop the hinged panel under the feed rolls and position the plastic collection tray directly underneath to catch any remaining seed or product.
2. Undo and remove the 2 black plastic knobs holding the mechanism in place and slide out the feed block assembly.

Be aware that the feed block assembly may retain some seed product.

3. Use an air line and brush to clean the feed block and internal components checking for any wear or damage replacing any worn or damaged parts as necessary. When doing this wear appropriate PPE.
4. Before re-fitting the feed block ensure that the feed shaft can easily be turned by hand using the black PVC knob fitted to the end of the shaft. If difficult to turn remove the end cap at the opposite end of the feed block assembly and remove all spacers and feed rollers by sliding each one off the shaft.
5. Check the drive shaft engages correctly when sliding the feed block back into the machine by slowly rotating the central black plastic knob before re-fitting the outer black plastic retaining knobs.

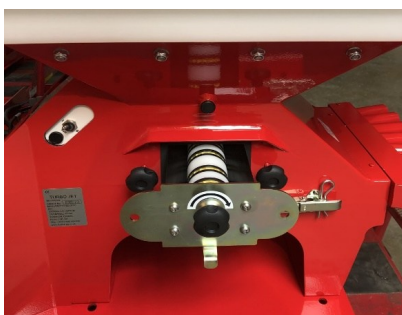

10.3 Agitator Shaft Inspection

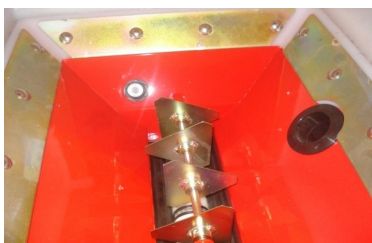

Check the internal agitator shaft to ensure it is clear of any debris and free to rotate.



11.0 Hopper Emptying Procedure

The hopper drain cap can be removed to help empty the hopper. Any remaining product is best removed by using an industrial vacuum before the feed block is removed from the machine.

Once the feed block has been removed from the machine dispose of any remaining product held in the feed block. Release the bottom calibration door and check the air chambers for any sign of debris or build up of product and clear as necessary.



12.0 Clearing A Feed Hose Blockage

In the unlikely event of a blockage, remove the hose and clear any obstruction from within the hose or manifold on the machine. Remove the feed block and check the air chamber below the feed block opening and clear any debris. Re-position the feed hoses if this has been the cause of the problem.

⚠ WARNING Always observe all application standards and guidelines provided by the product manufacturer as some seed dressings and granular products may be toxic.

NOTE: If unsure contact your seed or product supplier for more information.

13.0 Checking The Feed Motor

Firstly empty the hopper then remove the feed block assembly. Remove the motor guard by releasing the fixing screws.

Check to see if the feed motor shaft rotates when pressing the prime button.

If the shaft is not rotating this may indicate the motor is faulty or has been damaged and needs to be replaced.



⚠ WARNING This procedure must be carried out by a competent person who is aware of any risks involved as moving parts of this machine are powerful and can cause injury.

For any parts or if no faults are found and the alarm persists contact your local Stocks Ag dealer.

14.0 Jackal Control System Overview

All control system components integral to the applicator are factory fitted.

The instrument has a 128mm x 64mm Mono Graphic LCD Screen which has multiple functions.

Separate heavy duty power cable and head unit leads interconnect the tractor and the Seed Applicator Unit.

Electrical components supplied with the machine:

- Jackal Instrument (fitted with 3m instrument lead) c/w flylead to connect to a 7pin tractor cab socket

- Instrument mounting kit

- 5m instrument cable

- 5m fused power cable (machine junction box has a 3m flylead attached)

All components packed inside the hopper from factory.

14.1 Jackal Control System Options

1. Feed Cut Out Switch - this can be mounted in a suitable place on the implement or linkage of the tractor, thus deflecting the spring, and automatically switching the feed motor off or on accordingly as the circuit is made or broken.

2. GPS Speed Sensor Kit - to avoid any over applying of product this offers speed proportionate metering of product, maintaining the pre-set application rate in line with forward speed changes. If the system is then not able to maintain the rate it will alarm and alert the operator.

3. Hopper Level Sensor - alarms to warn the operator if the hopper contents are getting low.

4. Power and Instrument extension cables - available in 5m lengths.

Please contact your local Stocks Ag dealer for more details.

14.2 Control System Operation

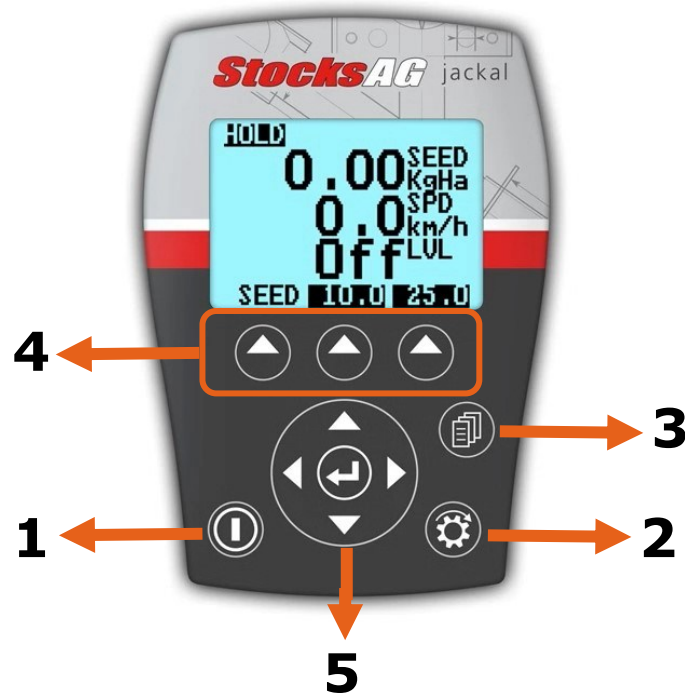

1. Power On/Off button

Power is turned on by pressing the **ON/OFF** button for 1 second.

Power is turned off by holding the **ON/OFF** button for 2 seconds.

2. Run/Hold button

The **RUN/HOLD** button has a dual function.

Press **RUN/HOLD** once to place the 'Metering unit ON HOLD'.

Press **RUN/HOLD** again to resume operation.

The **RUN/HOLD** state is indicated in the top left-hand corner of the screen. When the metering unit is in **RUN** mode, the unit displays **RUN** to signify that the metering unit is active (turning).

When the metering unit is in **HOLD** mode the unit displays the word "**HOLD**" & "beeps" every 2 seconds.

3. Page button

The **PAGE** button is used to scroll through function screens.

4. Select buttons

The Jackal has 3 buttons placed directly under the LCD. These buttons will change function in different menus.

The function of the button is indicated at the bottom of the screen directly above the button.

5. Navigation button (Up, Down, Left, Right, Enter)

The round navigation (**NAV**) buttons are used to navigate **UP/DOWN/LEFT/RIGHT** in calibration screens as well as scrolling through the display lines on the main screen.

ENTER is used to select the option highlighted onscreen.

14.3 Machine Junction Box

The Jackal Junction box (MMD) is located underneath a panel, which is the top half of the fan guard.

The single button on the side is for calibrating the Turbo Jet.

See Jackal control box instructions.

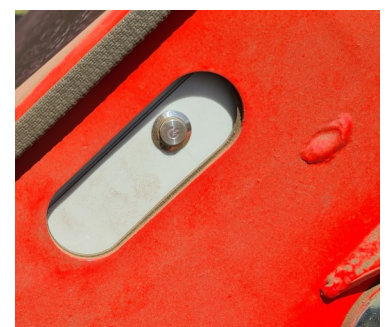

15.0 Electrical Components

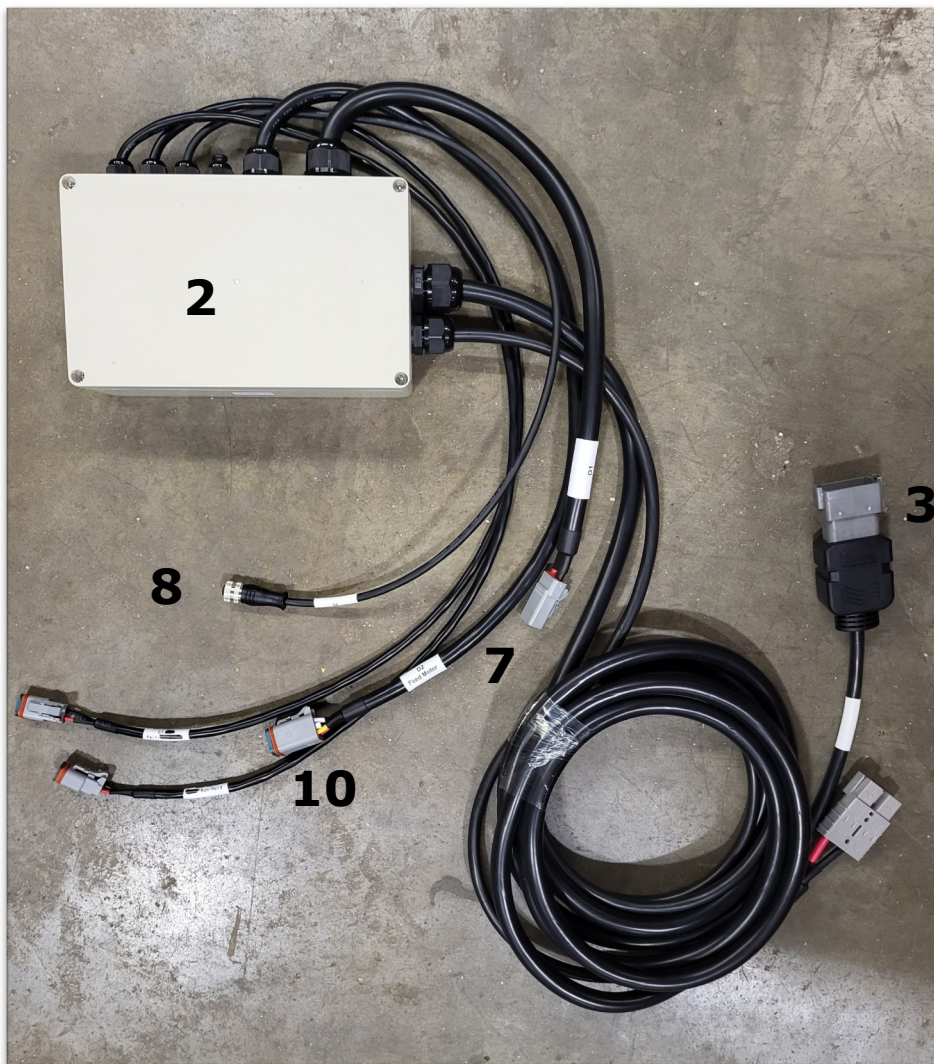

- | | |
|---|--|
| 1. Cab control panel | 8. Hopper level sensor connection - Optional |
| 2. Junction box (machine mounted) | 9. Agitator motor connection |
| 3. Control cable connection | 10. Feed motor connection |
| 4. GPS sensor connection - Optional (not shown) | 11. 6m control extension cable (not shown) |
| 5. Cut out switch connection - Optional | 12. 5m fused power cable (not shown) |
| 6. Power cable connection | 13. 5m power cable extension (not shown) |
| 7. 12v fan connection | |

15.1 Run Hold/Cut Out Switch - Optional

This optional switch can be mounted in a suitable place on the implement or linkage of the tractor, thus deflecting the spring, and automatically switching the feed motor off or on accordingly as the circuit is made or broken.



Part No: 47TJT50025

Position the optional finger switch so that the tip of the spring comes into contact with the moving part of the implement or linkage when lifted out of work and remains deflected until the implement is lowered back into work.

NOTE: Ensure that there is sufficient and positive deflection on the spring to prevent accidental switching ON or OFF if the implement moves slightly up or down in work.

The standard wiring as supplied for this switch is when the spring is at rest, the feed motor will run normally. If required the switch can work in the opposite mode by changing the setting on the head unit, see manual page 29 (section 16.3).

15.2 Hopper Level Sensor - Optional

There is an optional hopper level sensor available. This option is useful when the hopper of the applicator is out of view of the operator. The alarm will sound once the product in hopper drops below the level of the sensor.

For more information please contact your local Stocks Ag dealer.



Hopper level sensor - Part No: 47TJT5037

15.3 GPS Speed Sensor Kit - Optional

When a tractor's 7 pin implement socket is not available for a forward speed signal, the Jackal can be fitted with this optional GPS sensor kit. This will give speed proportionate metering of product whilst maintaining the pre-set application rate in line with changes in forward speed. The fly lead is required to connect the GPS receiver to the plug on the back of the head unit.



GPS receiver - Part No: 47TJT5036

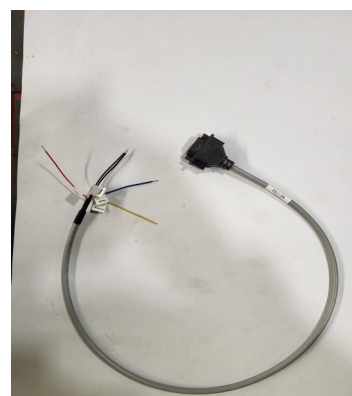

GPS fly lead - Part No: 97APC0048

15.4 Wiring For Optional Extras

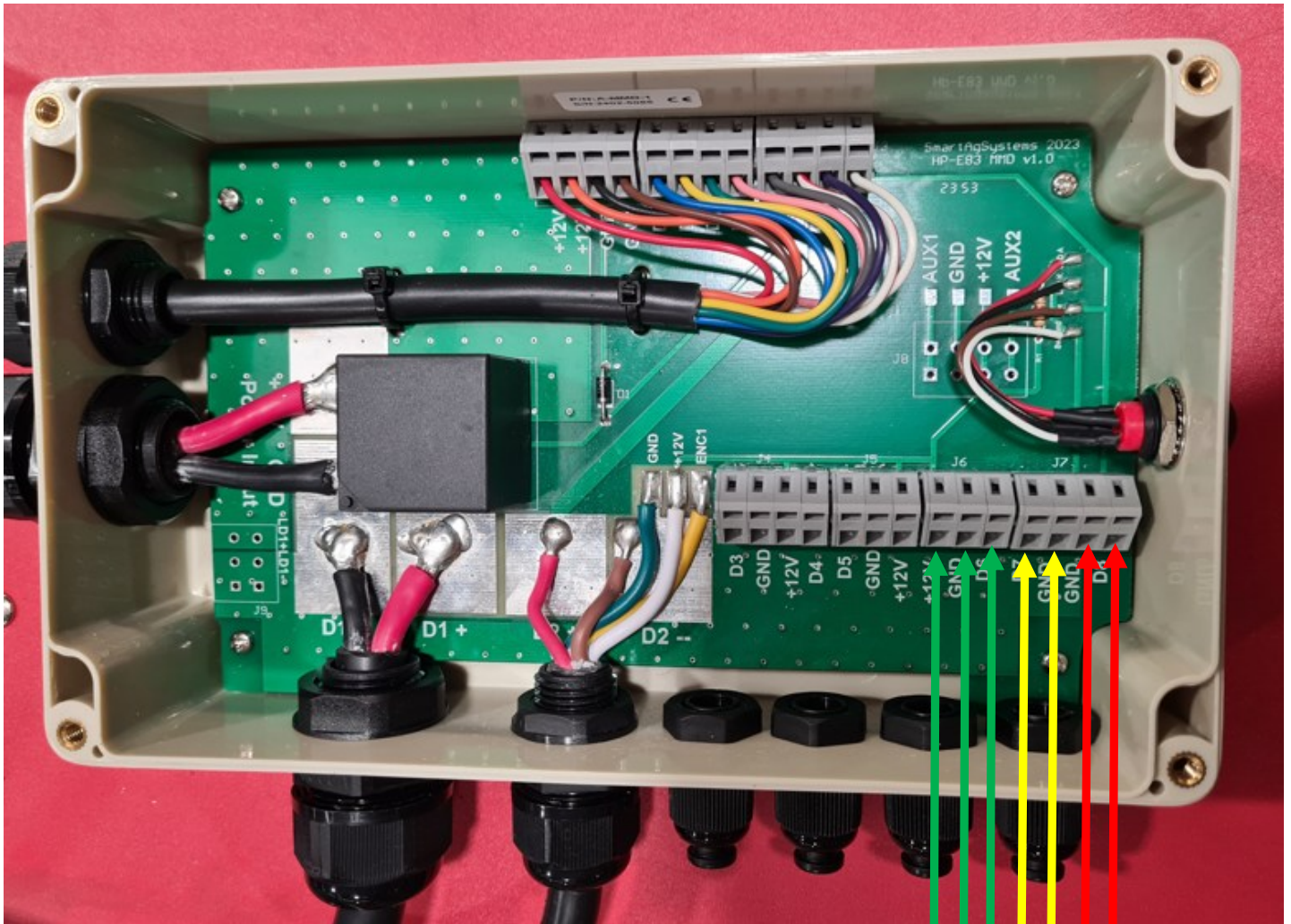

Hopper Level Sensor wire connections

BROWN = +12V

BLUE = GROUND

YELLOW / GREEN = D6

Agitator Motor wire connections

BROWN = D7

BLUE = GROUND

Cut Out Switch wire connections

BLUE = GROUND

BROWN = D8

16.0 Power Connection

Power connection must come directly from the battery terminals, **WARRANTY VOID** if power is not connected as described in this section.

Connect power cable supplied **DIRECTLY TO BATTERY**.

Ring terminals are used for battery connection and the bare end used to connect to the rear Jackal instrument. (Refer to the image below for power connection).

Connect Ground to BATT (-V) **Terminal A11** using the **RED** with **BLACK** stripe wire.

Connect **+12** Volts (+battery terminal) to BATT (+V) **Terminal A10** using the **RED** wire.

Ensure that the battery connection to the Jackal is +12 Volts

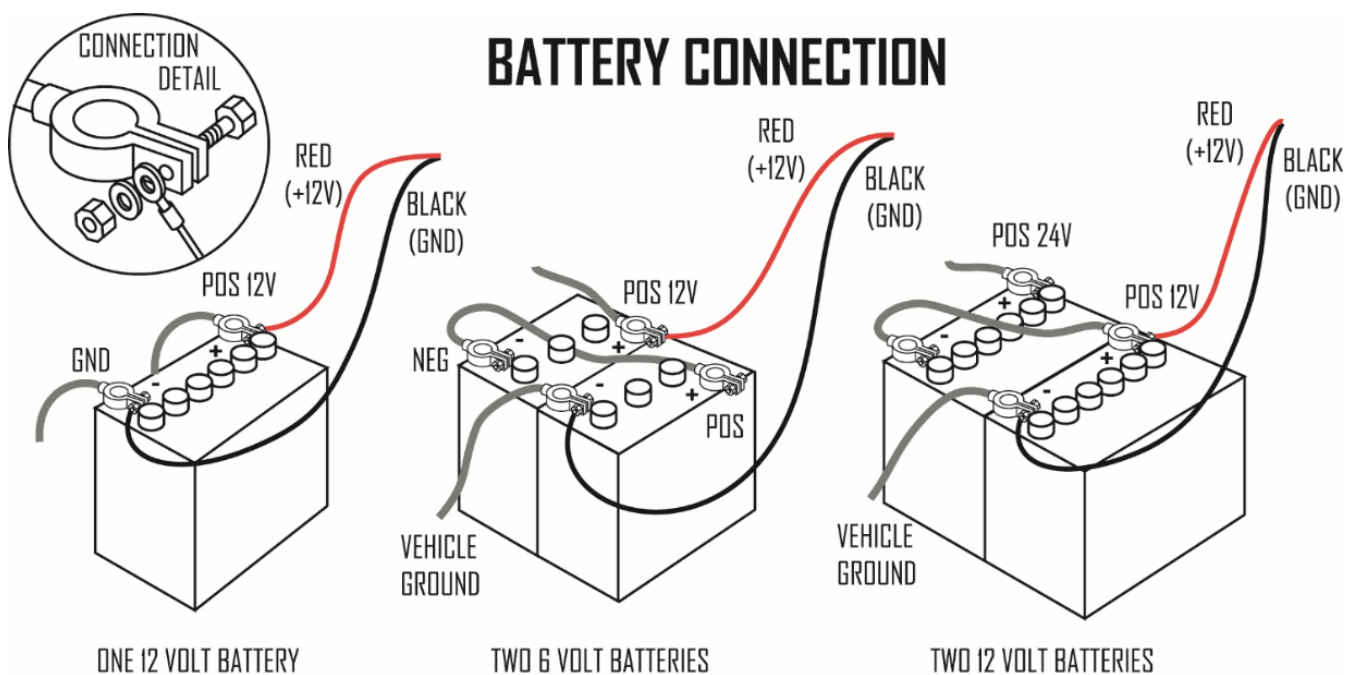

Connecting 24v to the Jackal **will damage the system and also VOID WARRANTY**



Disconnect the terminal plugs from the Jackal if **ARC WELDING** on machinery

16.1 Instrument Button Functions

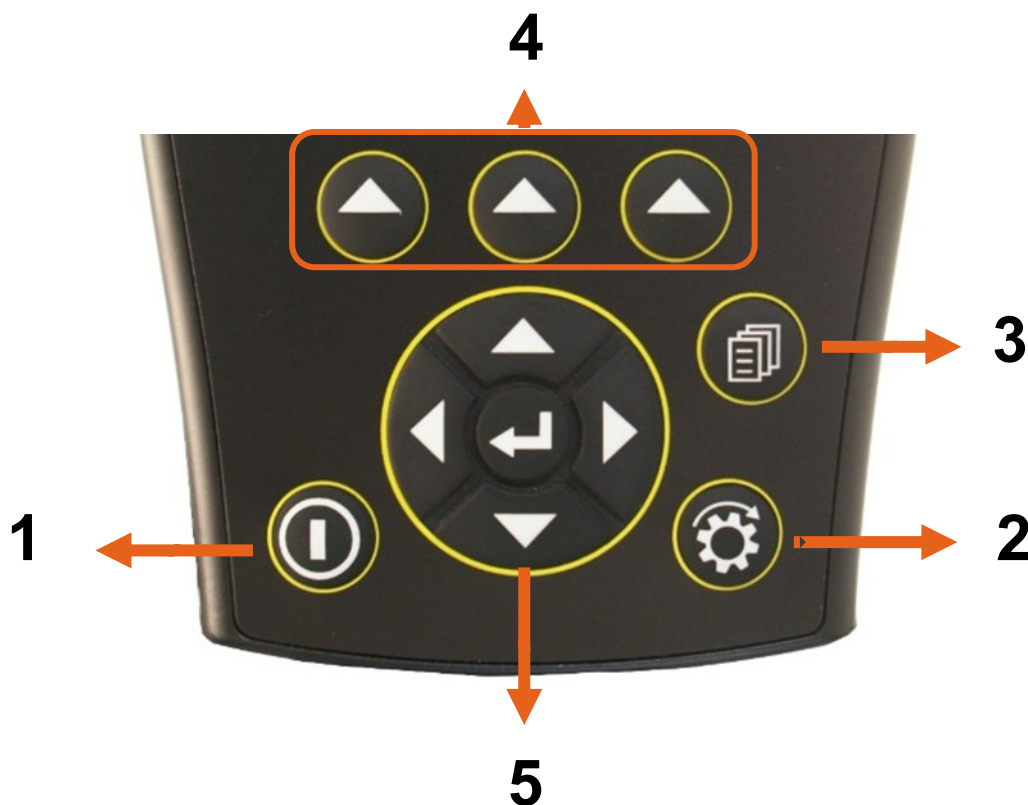

1. Power On/Off button

Power is turned on by pressing the **ON/OFF** button for 1 second.
 Power is turned off by holding the **ON/OFF** button for 2 seconds.

2. Run/Hold button

The **RUN/HOLD** button has a dual function.

Press **RUN/HOLD** once to place the 'Metering unit ON HOLD'.

Press **RUN/HOLD** again to resume operation.

The **RUN/HOLD** state is indicated in the top left-hand corner of the screen. When the metering unit is in **RUN** mode, the unit displays **RUN** to signify that the metering unit is active (turning).

When the metering unit is in **HOLD** mode the unit displays the word "**HOLD**" & "**BEEPS**" every 2 seconds.

3. Page button

The **PAGE** button is used to scroll through function screens.

4. Select button

The Jackal has 3 buttons placed directly under the LCD. These buttons will change function in different menus.

The function of the button is indicated at the bottom of the screen directly above the button.

5. Navigation button (Up, Down, Left, Right, Enter)

The round navigation (**NAV**) buttons are used to navigate **UP/DOWN/LEFT/RIGHT** in calibration screens as well as scrolling through the display lines on the main screen.

ENTER is used to select the option highlighted onscreen.

16.2 Initial Instrument Set Up

This display is called the **RUN** screen and displays the information required when the machine is in normal use.

It displays on a scrolling list:

Application Rate

Forward Speed

Hopper Level sensor

SCROLL DOWN TO VIEW

Fan Current (as a % of battery voltage)

Area Meter



Setting the Working Width

Using the **PAGE** button scroll through until the **SETUP** option displays over the select buttons.

Press the **SELECT** button to enter the **SETUP** Menu.

Using the **DOWN** Arrow on the Navigation key pad, scroll down to **Other Settings**.

Using either the **ENTER** button on the Navigation key pad or the right hand **SELECT** button, with **SELECT** above it, to confirm.



16.2 Initial Instrument Set Up - continued

Using the navigation keys, scroll down to implement width.

Press the left navigation button to highlight the numerical value to be adjusted.

Press **EDIT**

On the next screen enter the working width in metres.

To adjust the value, use the navigation up and down buttons to change the value.



Use the left and right buttons to select the unit to be adjusted.

The example across shows a working width of 8.5 metres being entered.

Press **EXIT** to save and go back to settings menu.



16.3 Run/Hold Automatic Switch

The Jackal has 3 main methods of switching the metering roller on and off. On is referred to as **Run** to apply product and off is referred to as **Hold** to stop the metering roller.

The **Run** or **Hold** button on the bottom right of the control box can be used to manually switch the metering motor on and off.

When using an implement attached to the 3 point linkage, the 7 pin implement socket in the cab can be used to provide an on/off signal for the **Run/Hold** function.

To use the 7 pin input as the **Run/Hold** function, the **Input#** must be set to **9**.

Note: This input may require changing, please contact Stocks for technical assistance to unlock this function.



There is also an optional cut out finger switch available.

This is set from factory to be in the **Hold** position when not activated (in its central rest position) and when the finger is moved, the metering motor will start or **Run**.

The set up for this function is displayed in **SET UP/ Other Settings**, scroll down to **Extern.Run/Hold**

This will be shown on the screen as **Normally Off**.

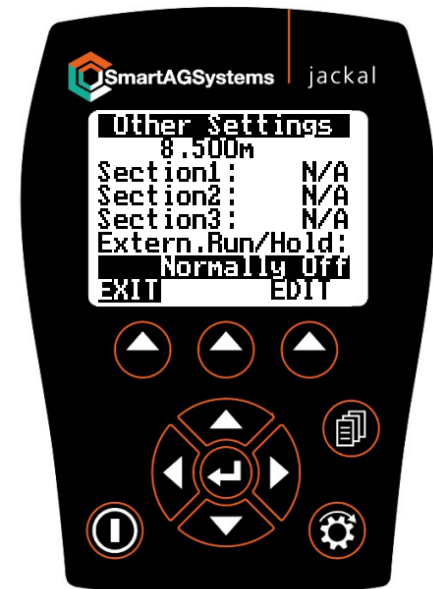

If required, the operation of the **Run/Hold** can be made to operate the opposite way round to suit a particular tractor or position of the optional finger switch.

Finger switch and 7 pin implement switch setting:

In **Set Up, Other Settings, Extern.Run.Hold**.

By changing the setting to **Normally On**, the machine will meter product with the **Run/Hold** finger switch in the rest position and then switch off when the **Run/Hold** finger switch is moved.



17.0 First/New Product Calibration

From the front screen, select **SETUP**, by pressing the arrow directly below.



Then select **Inputs** by pressing **SELECT** or the **Enter** button in the middle of the navigation keys.



Important! – On the first ever calibration run or when changing product types. Leave the target set to 0.000kg, do not enter a target weight.

To prime, first release the calibration door on the bottom of the machine and place the calibration tray underneath.

Press and hold the arrow button below **START** on the Jackal Instrument or the button on the applicator junction box.

Once product is dispensed, release the button. The screen will AUTO RESET for the calibration run.

To start calibration, you can either press and hold the arrow button under the word **START** on the screen.

Or press and hold the button on the junction box on the side of the machine.

The calibration run will stop when the button is released.



17.0 First/New Product Calibration—cont.

Weigh the product dispensed with scales that weigh in grams or kgs to 3 decimal places.

The TARGET line will now read **Actual**.

With **Actual** highlighted. Press the arrow key below **EDIT** and enter the weight of product dispensed.



A new screen opens to allow you to enter the weight of product dispensed.

Example: If you weighed 256 grams, you need to enter this as 0.256kg on the screen.

Using the left and right navigation key pad to highlight the figure that needs adjusting, use the up and down to change the figure.

To save and exit, press the arrow below **EXIT**.

DEL is to delete a digit and **INS** is to insert a digit.



To confirm the actual weight that has been entered, now press **CALC** to work out the new ratio.

Note: This ratio is the number of pulses from the encoder on the metering motor per kg of product.

For reference, the calculated ratio can be recorded along with the product type and feed roller set. This ratio can be entered manually to quickly change between products in the future.

Scroll down to highlight Manual Ratio press **EDIT** and enter the recorded figure.

To save and exit, press **EXIT**.



17.1 Product Calibration

From the front screen, to select **SETUP** press the arrow directly below.



Then select **Inputs** by pressing **SELECT** or the Enter button in the middle of the navigation keys.



Once the first calibration run has been completed and calculated, the manual ratio will change.

A target rate can now be entered.

Using the Navigation keys, scroll down to highlight **Target**.

Press the arrow key below **EDIT**.



17.1 Product Calibration - continued

This is the weight you want to dispense during your calibration. This is usually 0.100kg (100 grams) up to around 0.800kg (800 grams).

Example: Set to 300 grams or 0.300 kg.



To prime, first release the calibration door on the bottom of the machine and place the calibration tray underneath.

Press and hold the arrow button below **START** on the Jackal Instrument or the button on the applicator junction box. Once the product is dispensed, release the button. The screen will auto reset for the calibration run.

To **START** the calibration, you can either press and hold the arrow button under **START** or press and hold the button on the side of the applicator junction box.

The calibration run will stop when the target rate is reached or when the button is released.



17.1 Product Calibration - continued

Weigh the product dispensed with scales that weigh in grams or kgs to 3 decimal places.

The TARGET line will now read **Actual** with **Actual** highlighted. Press the arrow key below **EDIT** and enter the weight of product dispensed.



Example: If you weighed 256 grams, you need to enter this as 0.256kg on the screen

To save and exit, press the arrow below **EXIT**



17.1 Product Calibration - continued

To confirm the actual weight that has been entered, now press **CALC** to work out the new ratio.

Note: This ratio is the number of pulses from the encoder on the metering motor per kg or product.

For reference, the calculated ratio can be written down along with the product type and feed roller set. This ratio can be entered manually to quickly change between products in the future.



Scroll down to highlight **Manual Ratio** press **EDIT** and enter the recorded figure.



To save and exit, press **EXIT**.



18.0 Spreading/Applying Product

NOTE:

These instructions are for the 12v electric fan. If the applicator is fitted with the optional hydraulic fan, turn the fan on using the tractors hydraulic remote (spool) valves.

See section at the rear of this manual.

From the HOME screen, using the **PAGE** button, scroll through until **FAN** is displayed.



Press the arrow button directly below **FAN** to switch the fan on.



When **FAN** is highlighted, the fan should be running.

Using the down arrow on the navigation key pad, scroll down to see the **FAN %** display.

This display shows the 12v electric current being supplied to the fan.

Note: The fan will quickly get up to speed, the % counter takes longer to count up. The % must be at least 70% before the feed rollers can be turned on.



18.0 Spreading/Applying Product - cont.

For the machine to operate, the **RUN/HOLD** in the top left of the screen, must display **RUN**.

This is either switched by the linkage position switch/sensor. (This is either on the 7 pin plug or external finger switch, if supplied).

Alternatively, if there is no 7 pin input or external finger switch, the **RUN/HOLD** button on the bottom right of the keypad can be used to switch the metering unit on and off.



As the machine is about to start work, set the application rate required. This can be done by selecting one of the two pre set "quick rate" buttons, as highlighted opposite.

See *Quick Rate* section to adjust the pre set rates.

Until the machine is moving, **STOP RATE** will be displayed in the top right of the screen.



Alternatively, the rate can be set manually on the **RATE+** or **RATE-** page.

Once the machine starts to move, the forward speed will be displayed and the **STOP** message will change to **OK**.

The applicator should now be applying product.



19.0 Simulated Speed

Simulated speed is used when no forward speed input is available, or if you need to run the machine while stationary for testing.

If simulated speed is switched on, it will override any external speed input.

Select the Other Settings page by selecting **SETUP** then **Other Settings**, scroll down to **SimulSpeed**.

The simulated speed can be switched on or off by highlighting **YES** or **NO** and pressing the arrow key below **EDIT** or the Enter Button.

To return to the Run/Home screen press **EXIT** to save and **EXIT** each screen.



When simulated speed is turned on, this function is now available when scrolling through the screen functions using the **PAGE** button.

The simulated speed function must be switched off to allow an external forward speed input to alter the application rate as the tractors speed changes.

The speed can be adjusted on the move and the feed rate will adjust accordingly.



19.1 Alarms and Trip Functions

Alarms

The Alarms page is accessed from the home screen, using the left hand select arrow.

The Alarms are listed and show which alarms are active.

The alarm function should be set to AUTO.

=AUTO: As soon as the value moves back within the min and max range the monitor will automatically reset the alarm.

=ON: When the alarm is activated it will remain ON until you enter the ALARM menu and manually reset.

=OFF: You can disable the alarm altogether.



Trips

The Trips page allows accumulating area (hectare) values to be saved and recalled at a later time.

From the front-page press **TRIP**, the screen opposite allows you to SAVE/RESET individual trips or view SAVED TRIPS.

By pressing the **SAVE/RESET** you have the ability to Reset Trip | Save Trip | Reset All. (see below)

By pressing **2. Save Trip** it will be stored in the SAVED TRIPS option.

You can now view the **SAVED TRIPS**. You also have the ability to **EDIT** and name the Trip or **DEL ALL** (Delete All Trips).

When you return to the TRIPS page the Trip will continue to accumulate.

You will need to SAVE/RESET the trip if you want to start from Zero (0) again.



```

Trip Edit
5:AREA 0.00Ha
    
```

```

1. Reset Trip
2. Save Trip
3. Reset All
    
```

```

EXIT          SELECT
    
```

19.2 Quick Rate and Step Size Adjustment

The pre set quick rates can be set to whatever is required.

From the front screen settings, the size of the step rate can be adjusted.

To get to the Front Screen, use the page button until SETUP is displayed. Select SETUP, then scroll down to Front Screen and select.

When the Front screen is displayed, as opposite, select **1: SEED** by highlighting and press **EDIT**.



Scroll down until **Step:** is visible.

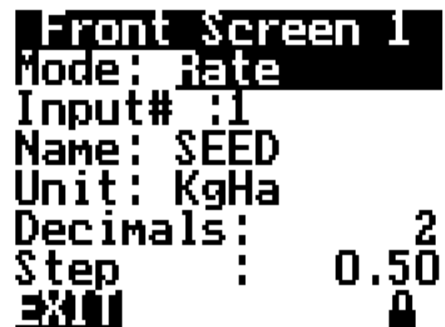

To adjust the Step size, scroll down to highlight **Step**. Press **EDIT** and set the required **Step** size in kg/ha (screen opposite shows steps of 0.50 kg/ha).

Press **EXIT** to save and exit.

0.50000 is a 500 grams or 0.5 kg step size.

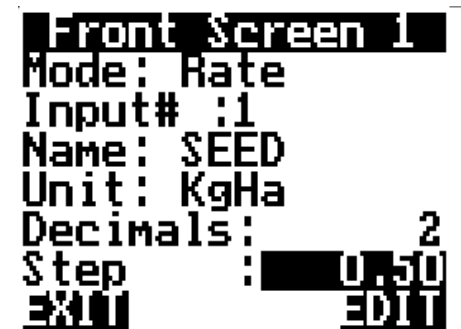

To adjust **RateA** and/or **RateB**, scroll down and highlight the one to be altered. Then press **EDIT**.

Enter the required rate and press **EXIT** to save and exit.

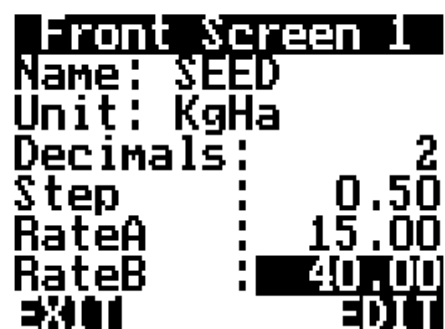

19.3 Flush/Hopper Empty

The Jackal has a Flush or Hopper Empty function.

Use the Page button to scroll through the function until **SEED** and **Flush** are displayed above the arrow buttons.

Open the calibration door and place a suitable bucket or container underneath.

To begin emptying, press the arrow button under **Flush**.

The Flush icon will begin to flash and the metering unit turns.

Press again to stop.



19.4 Diagnostics

The Diagnostics page is accessed from the **SETUP** page and scroll down to Diagnostics.

This page will display supply voltage and current being drawn.

Each input and output set up on the Jackal is displayed. When switched on or operated it will show a voltage or hertz reading.



20.0 Feed Block Kit Information

⚠ WARNING! Moving parts of this machine are powerful and can cause injury. Be especially careful whilst performing calibration tests. Always observe all application standards and guidelines provided by the product manufacturer as some seed dressings and granular products may be toxic.

If unsure contact your seed or product supplier for more information.

NOTE: Before applying very fine seeds or product please contact your local dealer or Stocks Ag directly to ensure the machine is suitable. Failure to do so could invalidate your warranty.

20.1 Large Seed Feed Block Kit

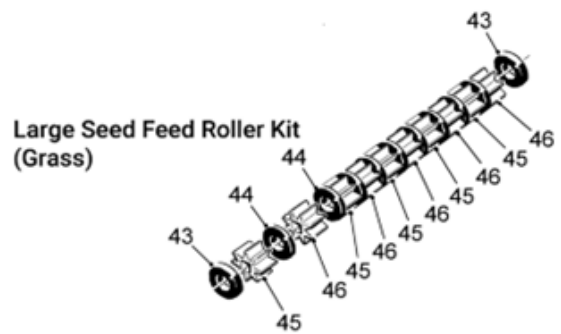
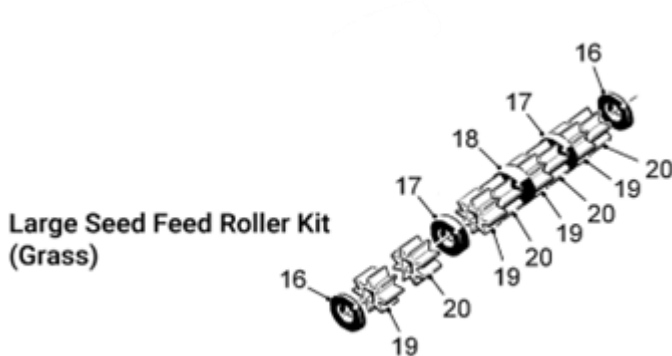

Part Number: **47TJT5003** (8 outlet machine)

Part Number: **47TJT5013** (10 outlet machine)

Supplied from factory with 8 or 10 feed rollers (1 feed roller per outlet) for grass seed application typically applied at 35kg/ha.

Half Rate Large Seed Set Up

For lower output for example when applying over a narrow working width or to apply most **cover crop mixes** the number of feed rollers will need to be reduced (1 feed roller per 2 outlets) by fitting the 15mm and 39mm wide spacers supplied with the kit.

8 Outlet Example

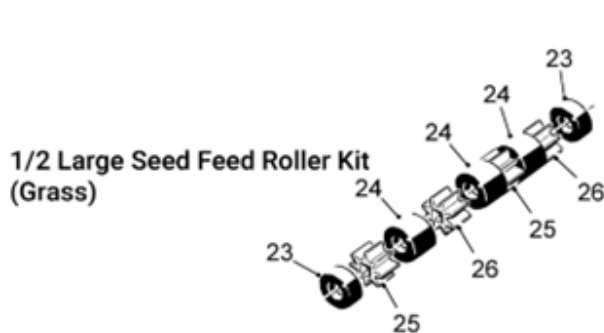

10 Outlet Example

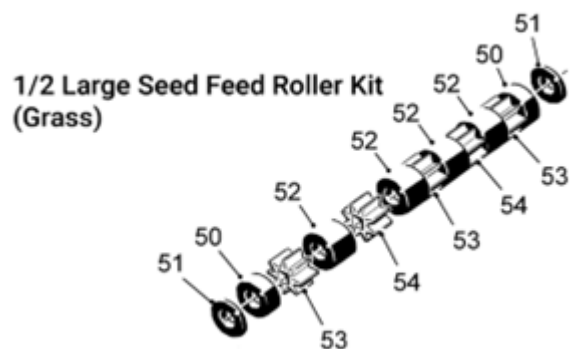

WARNING! It is the responsibility of the operator to ensure the feed block assembly is suitable for the product being applied.

20.2 Precision Small Seed Feed Block Kit

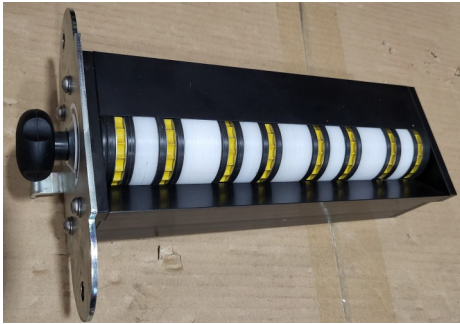

Part Number: **47TJT5002** (8 outlet machine)

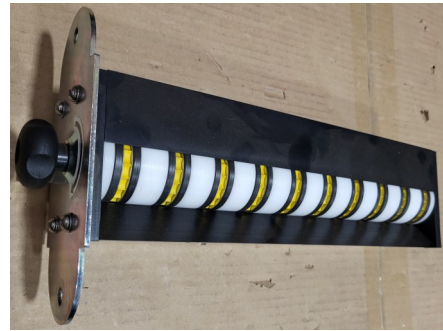

Part Number: **47TJT5012** (10 outlet machine)

This block has been developed to eliminate finer products from leaking around the feed rollers and into the airstream and is required **for low rate work such as small seed and slug pellet application.**

Yellow feed rollers are fitted from factory and typically used for small seed application such as OSR with 1 feed roller fitted over each outlet as shown below. If higher rates are required the **white** feed rollers, also supplied in the kit, can be fitted to increase output.

NOTE: Yellow feed rollers apply approximately 40% less than the white rollers - product dependent.

If you cannot achieve the required rate using just a single yellow or white roll, then use multiple rolls together per outlet for example 2 or 3. You can also mix the yellow and white provided each outlet has the same configuration of feed rolls. Other components from this kit, which include 16 white feed rollers and 3 black 5mm blanking spacers can be found in a bag packed inside the hopper.

NOTE: Before applying very fine seeds or product please contact your local dealer or Stocks Ag direct to ensure the machine is suitable. Failure to do so could invalidate your warranty.

The feed rollers are easily exchanged by removing the feed mechanism as follows:

1. Ensure the hopper is completely empty.
2. Undo and remove the 2 black plastic knobs holding the mechanism in place and slide out the feed block.
3. Undo and remove the 4 socket head screws on the end of the housing and remove the end plate. Slide the feed rollers and spacers off the shaft and replace with the alternative rollers required.

The black blanking spacers (3 supplied) are the same width as the small seed rolls and are used in combination with the feed rolls to allow 1, 2 or 3 feed rolls per outlet to be used or to replace the feed rolls and blank off an outlet completely. For example if reducing the number of outlets from 8 to 7, to correspond with subsoiler legs or tines, remove all the feed rollers from that outlet and replace with a 5mm blanking spacer.

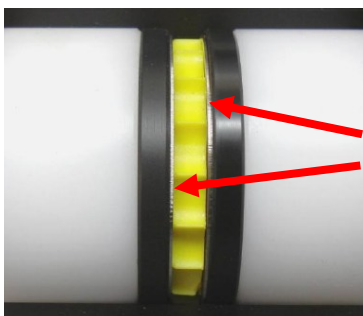

Note: One stainless steel disc needs to be fitted to each side of a single, or opposing ends, of multiple small seed segments. They are used to reduce friction between the small seed segments and the plastic spacer that are on each side.

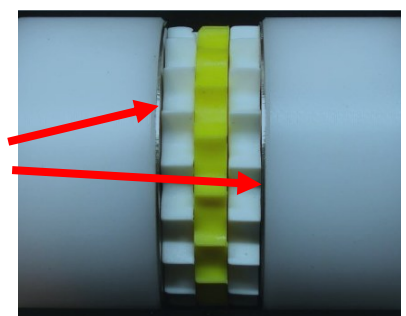

Remember to blank off the relevant manifold pipes using the push-in PVC plugs supplied.

NOTE: When re-fitting the end plate to the feed block after changing the feed roller configuration, the end plate should be able to fit flush with the feed block by hand, without having to pull it home with the socket head screws. The assembled rolls and spacers should not be under compression. Once re-assembled, slide the feed block assembly back into the machine ensuring the drive shaft engages correctly by slowly rotating the feed shaft. Once engaged secure the two black plastic retaining knobs.

⚠ WARNING! It is the responsibility of the operator to ensure the feed block assembly is suitable for the product being applied.

20.3 Granular Feed Block Kit

Designed for fine granules at higher application rates such as Avadex®* Excel 15G at 15kg/ha and can also be used for fine seed work where high outputs are required.



Part Number: **47TJT5020** (8 outlet machine)



Part Number: **47TJT5021** (10 outlet machine)

NOTE: If replacing the feed rollers always ensure the outer two rollers are positioned so that the blank end of the feed roller faces each of the black PVC end plates.

Avadex ®* is a Trademark used under licence by Gowan Crop Protection Ltd.

20.4 Stainless Feed Block Kit

Designed for applying abrasive granular products such as starter fertiliser or low rates of standard prilled fertiliser. (Supplied with 3 sizes of 5mm wide stainless feed rollers for different application rates).

NOTE: For higher standard fertiliser application rates our large seed block kit may be suitable.

Please contact your dealer for more information.



Part Number **47TJT5022** (8 Outlet Machine)



Part Number **47TJT5023** (10 Outlet Machine)

⚠ WARNING! It is the responsibility of the operator to ensure the feed block assembly is suitable for the product being applied.

NOTE: Before applying very fine seeds or product please contact your local dealer or Stocks Ag directly to ensure the machine is suitable. Failure to do so could invalidate your warranty.

21.0 Hopper Baffle Plate

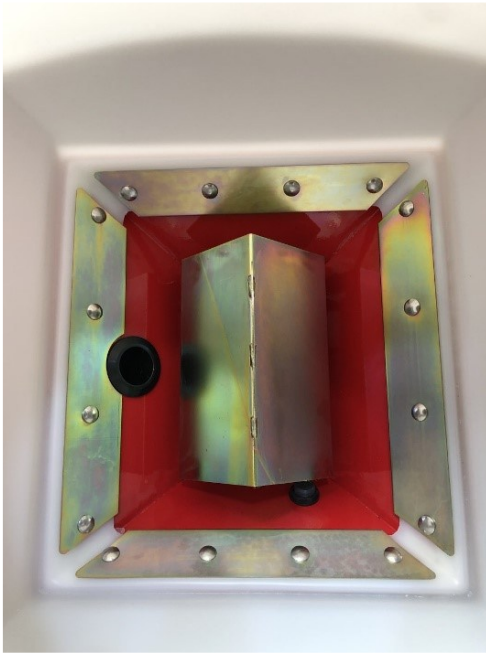

Turbo Jet 8 Hopper Baffle Plate
Part number: **TJ471**

Turbo Jet 10 hoper baffle plate
Part number: **TJ472**

WARNING A Hopper Baffle Plate must be fitted when applying fertiliser or any other dense product to reduce the pressure on the feed block assembly and so reduce strain on the feed motor. Failure to do so may damage the feed motor and invalidate the warranty.

NOTE: All 400L machines are supplied with a hopper baffle plate as standard.

22.0 Ready For Work

Once calibrated your machine is ready for work

1. Remove the calibration tray and store away safely.
2. Close the hinged drop down panel and secure with the over centre catches.
3. Ensure the agitator is running if required.
4. Check all outlet pipes are seeding correctly.
5. Ensure that you are travelling at the correct chosen speed if not using the optional GPS Kit.
6. Stop after a few metres – check for even distribution, spread and application rate.
7. Commence work checking periodically to ensure the machine is working correctly.

If you are unable to calibrate correctly or you have any other questions about the machine please contact us.

CAUTION. The feed rolls and agitator can pull in hair or loose clothing. The motor is so powerful that you will be unable to stop it.

Always clean out the machine at the end of the day, use a brush not your hand to sweep out the hopper.

⚠ WARNING! Always observe all application standards and guidelines provided by the product manufacturer as some seed dressings and granular products may be toxic.

NOTE: If unsure contact your seed or product supplier for more information.

23.0 Hydraulic Fan (Optional)- Specification

Hydraulic Fan Specification		
Model	FC4	
Max RPM	7000	rpm
Max Operational RPM	6000	rpm
Max Pressure	210	bar
Max Operational Pressure	172	bar
Displacement	4.1	cc
Flow	27.3	L/min
Power	9.54	NM
Weight	16	kg

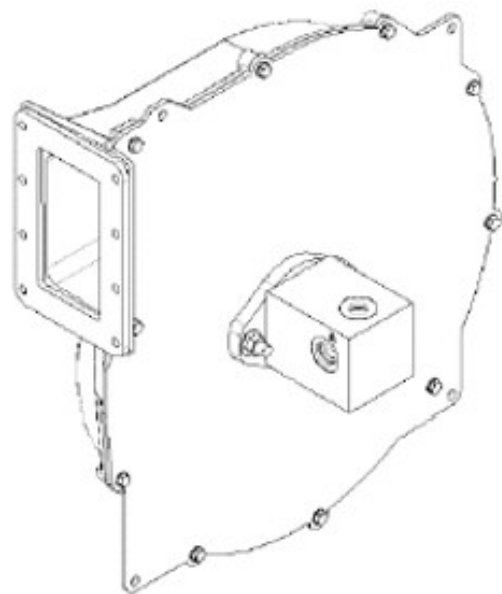

23.1 Hydraulic Fan - Safety

The hydraulic system on the machine operates under high pressure. (Maximum of 210 bar). Pressurised hydraulic oil is dangerous so connecting/disconnecting the fan must only be undertaken with the tractor engine turned off and the pressure in the hoses released. Before operating the machines hydraulics, always inspect the hoses and fittings to ensure there is no damage or loosened parts. If you find any damaged hoses, you must contact your dealer to have them replaced immediately.

Never try to block leaking hydraulic hose pipes with your hand or fingers! Hydraulic oil leaking out under high pressure may enter the skin and bloodstream and cause serious injuries. If injuries caused by hydraulic oil occur, immediately contact the medical services.

The tractor must be equipped with a free-return flow hydraulic connector (NO BACK PRESSURE). The oil flow necessary to drive the fan is taken from the tractor hydraulic remote valves, through a 3/4 inch delivery hose with BSP male fitting. The rotational speed of the hydraulic motor, and therefore the fan, is connected to the oil flow adjustable from the tractor's controls. The hydraulic motor safety valve makes it possible for the device to keep on turning by momentum, even after the system has been shut off. It is important to connect the return hose of the hydraulic motor to a free flow connection on the tractor; this free discharge cannot generate any back-pressure exceeding 2 bar.

Failing to follow these instructions will increase the risk of motor failure and increase the risk of premature failure.

23.2 Hydraulic Fan - Fitting Position

The hydraulic fan will draw in large quantities of air when running. The air inlet to the fan must be kept clear of obstructions. Where possible, mount in a location that will minimise the amount of dust being drawn in, as this will impede the performance of the applicator.

The hydraulic fan is supplied with a pair of 4 metre long hoses, for pressure and return to reach from the fan motor to the remote (spool) valves on the tractor. For trailed implements, please allow some extra slack in the hoses, which will be required when making sharp turns.

The hydraulic fan is supplied with a 2 metre hose that connects the fan outlet to the air inlet manifold of the applicator.

23.3 Hydraulic Fan - Speed Setting

The hydraulic fan generates a greater volume of air flow at higher speeds than the 12v electric fans, allowing higher volumes of material to be conveyed over wider working widths.

The fan is driven by a hydraulic motor, which is powered by the tractor hydraulic system.

The hydraulic motor has a overrun protection built in.

The rpm of the fan is measured by a NPN (Negative Positive Negative) sensor with a two pulse pick up point (2ppr).

The fan speed determines the volume and speed of air used to deliver product to the outlets. The correct speed required varies depending on product size, application rate and overall working widths. Fan speed is altered by adjusting the flow control on the hydraulics of the tractor.

If the tractor is not equipped with variable flow control on the hydraulic remote (spool) valves, there is a flow control valve available as an optional extra. This valve fits on the pressure hose at the tractor end. The speed is adjusted by restricting the oil flow to the fan.

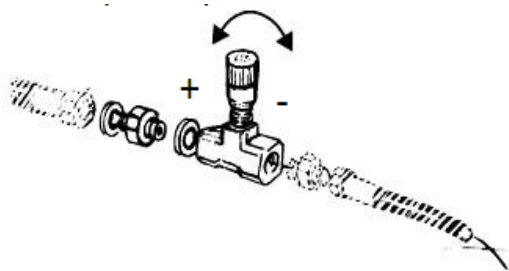

Optional flow control valve for adjusting fan speed

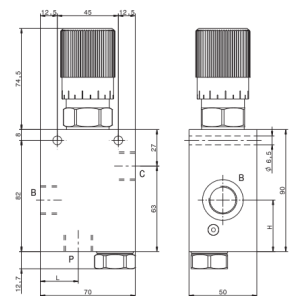

23.4 Hydraulic Fan Speed Guide

The fan speeds in the table below are just an rough guide. The correct speed required will alter greatly between varying setups depending on machine location, hose length and hose routing.

Fan Speed rpm	6m	8m	12m	15m
3500	Small seeds, OSR, Clover	Small seeds, OSR, Clover		
4000	Slug pellets, Avadex	Small seeds, OSR, Clover		
4800	Barley, Wheat, Fertiliser	Slug pellets, Avadex	Small seeds, OSR, Clover	Small seeds, OSR, Clover
5500	Larger Seeds, peas	Barley, Wheat, Fertiliser	Slug pellets, Avadex	Slug pellets, Avadex
6000	Larger Seeds, peas	Larger Seeds, peas	Barley, Wheat, Fertiliser	Barley, Wheat, Fertiliser

23.5 Hydraulic Fan - Speed Display

When the hydraulic fan option has been purchased, the Jackal control box will come pre-configured to display the fan speed on the screen in rpm.



23.6 Hydraulic Fan - Speed Sensor

The fan speed sensor requires mounting in the grill over the fan inlet, using the hole provided.

Each time one of the bolt heads mounted on the fan blade passes in front of the sensor, it generates a pulse and the LED on the back flashes red.

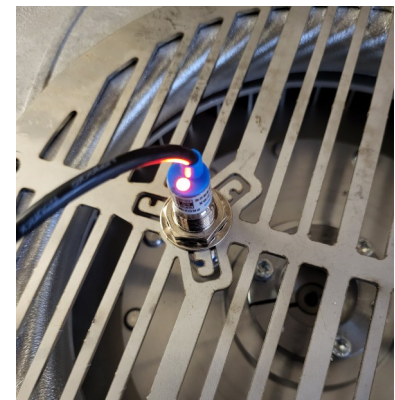

The picture opposite shows the two bolt heads that are used as the pick up points for the fan speed sensor.

The grill over the fan inlet has to be removed to fit the sensor. The grill is held in place with four M8 bolts.

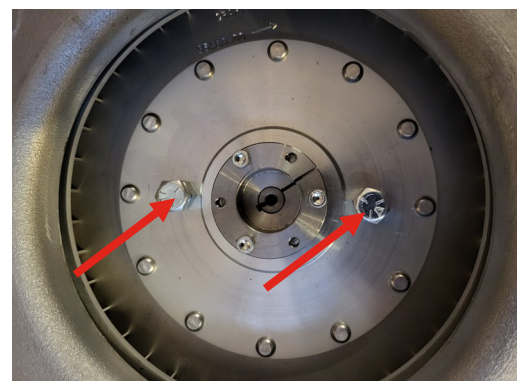

It is vital to install the fan speed sensor in the correct position. The sensor has an M12 fine thread with two nuts and lock washers to hold it in place. The blue tip to the sensor is roughly 30mm from the underside of the grill cover.

The critical measurement is the 1.5mm clearance between the sensor tip and the bolt heads. If the distance is too great, the LED will not flash. If it is too little, there is a risk of permanent damage to the sensor.

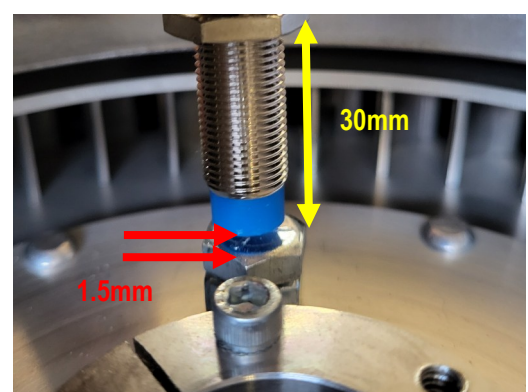

23.7 Hydraulic Fan - Mounting

To mount the hydraulic fan, the back plate is pre drilled with four M8 bolt holes.

It is recommended that all four bolt holes are used to mount the fan on a frame to support the fan securely.

The diagram below give the dimensions for the hole location and spacing.

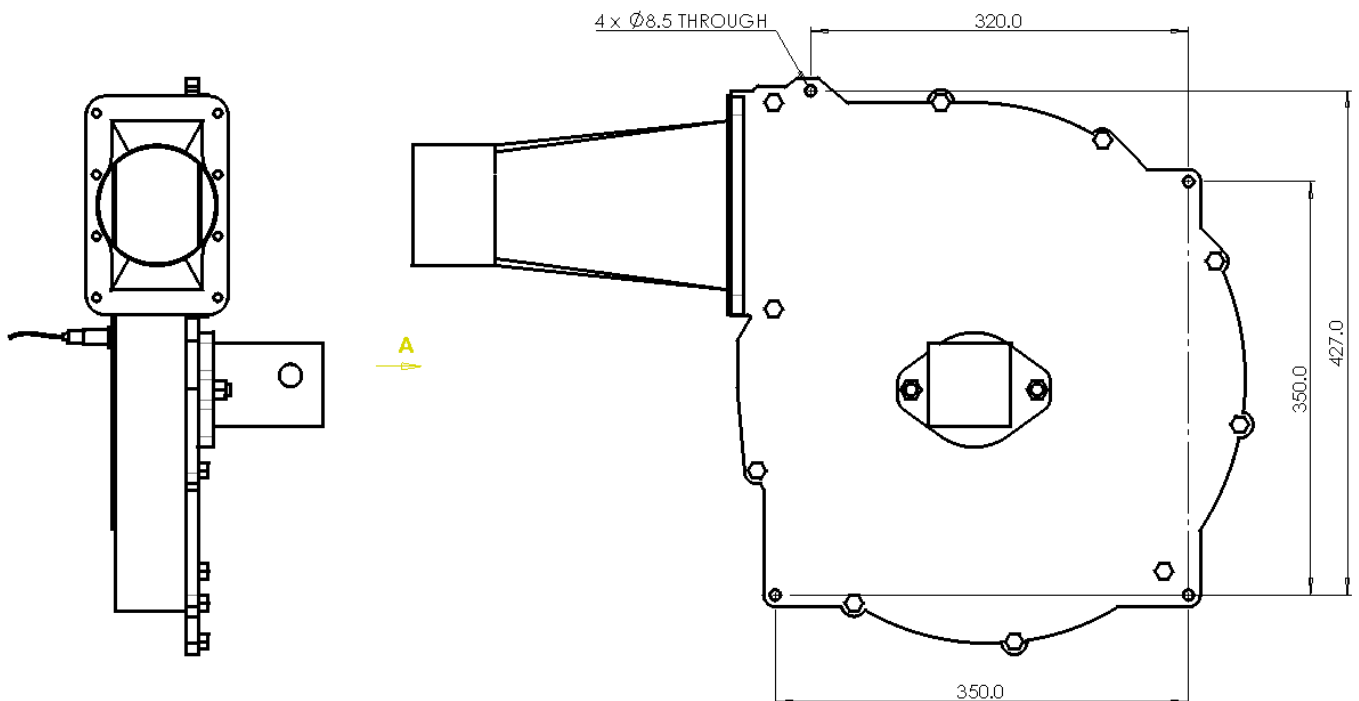

23.8 Hydraulic Fan Speed - Fly Lead Wiring

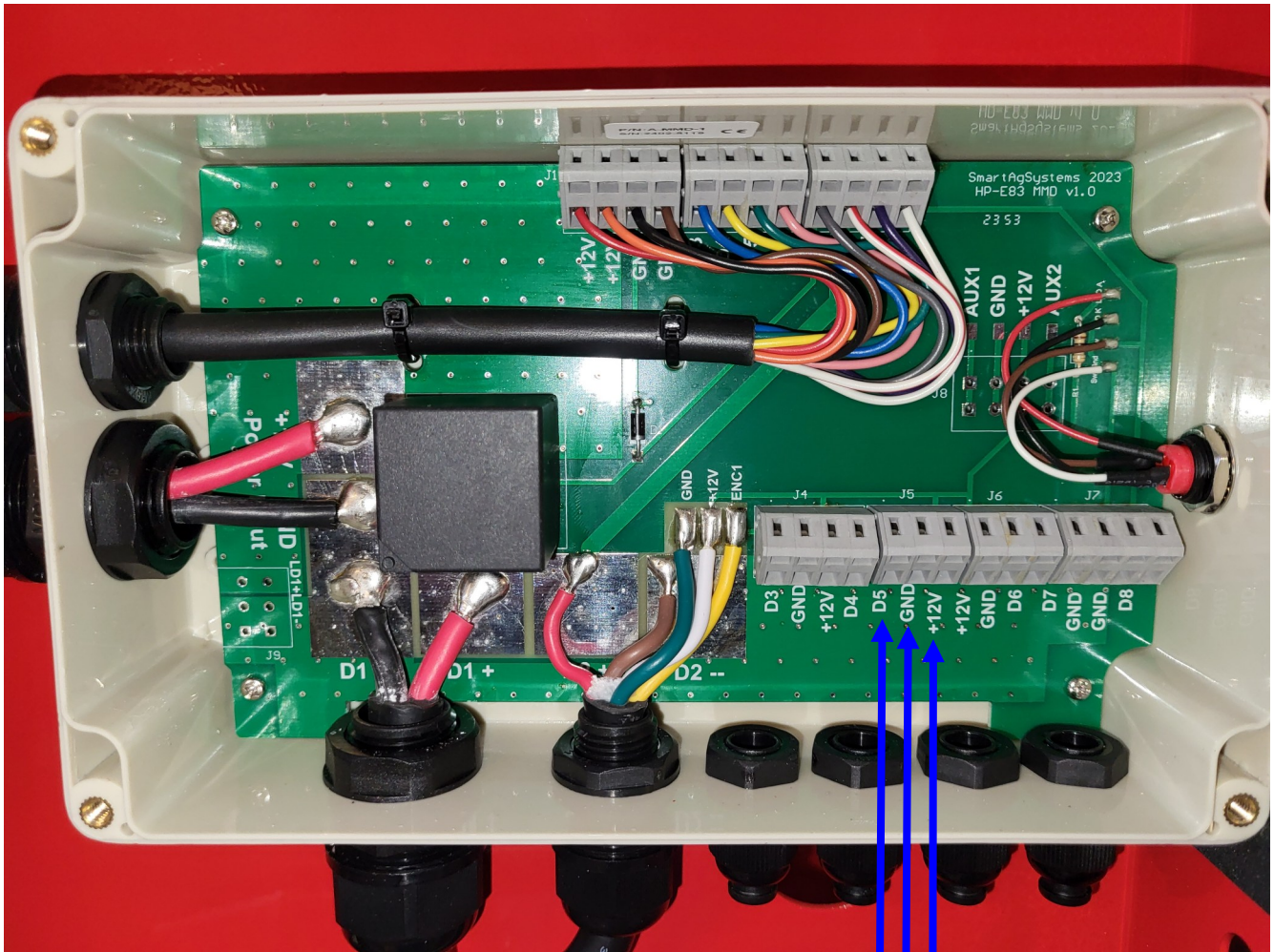

Hydraulic Fan Speed Sensor wire connections

YELLOW / GREEN = D5

BLUE = GROUND

BROWN = +12V

24.0 Turbo Jet Parts Diagram

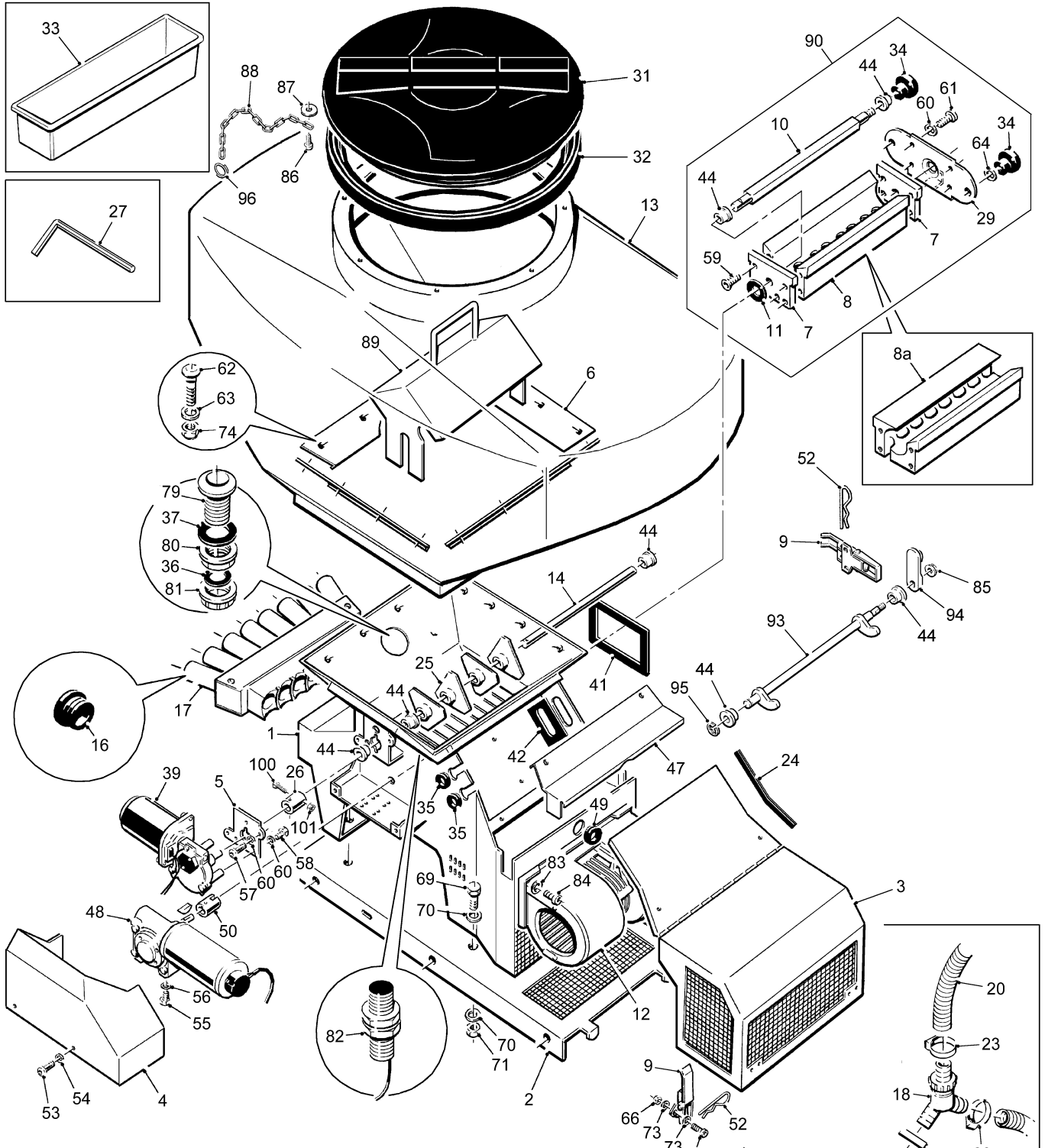

TJ-SP018

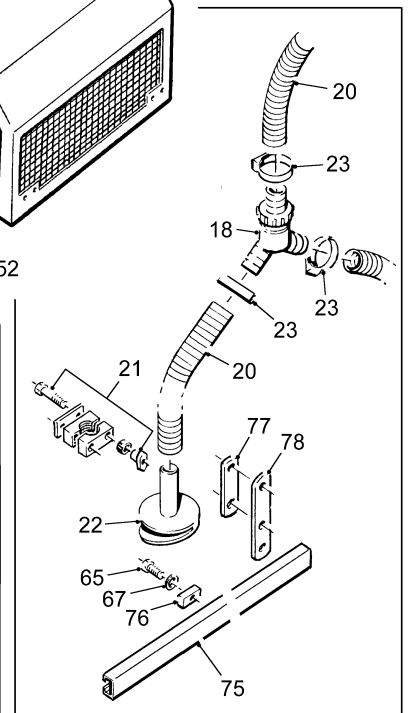
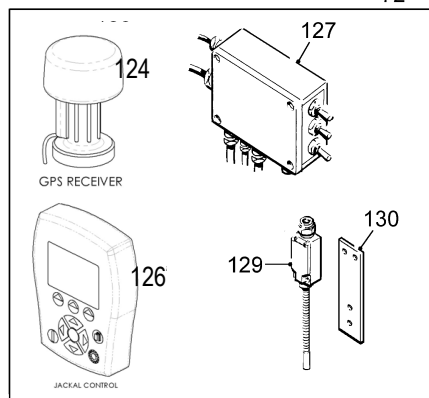
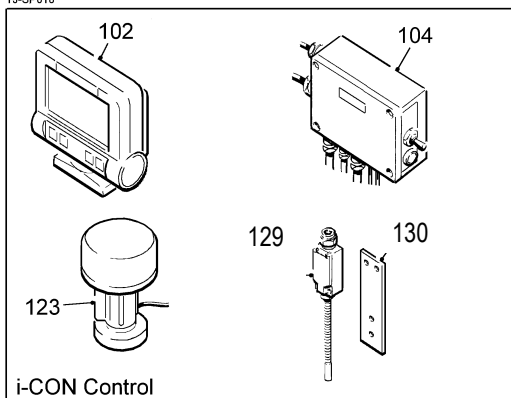

24.1 Turbo Jet Parts List

Item	Part No.	Description	Qty.	Remarks
1	TJ400A	Chassis (8 outlet)	1	
	TJ400B	Chassis (10 outlet)	1	
2	TJ422	Base Plate (8 & 10 outlet)	1	
3	TJ425A	Fan Guard (8 outlet)	1	
	TJ425B	Fan Guard (10 outlet)	1	
4	TJ418	Motor Guard (8 outlet)	1	
	TJ459	Motor Guard (10 outlet)	1	
5	TJ429	Agitator Motor Plate	1	
6	TJ465	Support Plate Kit	1	Set of 4 plates
7	TJ101A	Feed Block End Cap		
8	TJ102	Feed Block (8 outlet)		
	TJ098C	Feed Block (10 outlet)		
8a	TJ102A	Low Rate Feed Block (8 outlet)		
	TJ098D	Low Rate Feed Block (10 outlet)		
9	TJ103	Fastener Assembly	4	
10	TJ104D	Metering Shaft (8 outlet)		
	TJ099C	Metering Shaft (10 outlet)		
11	TJ033	Feed Block Gasket		
12	TJ124	Double Fan Unit (8 & 10 outlet)	1	
13	TJ126A	Hopper (240L)	1	
Or	TJ125A	Hopper (400L)	1	
14	TJ138	Agitator Shaft (8 outlet)	1	
	TJ138A	Agitator Shaft (10 outlet)	1	
16	TJ219-1	Manifold Blanking Plug		As required
17	TJ218A	Feed Unit Manifold (8 outlet)	1	
Or	TJ217A	Feed Unit Manifold (10 outlet)	1	
18	TJ220-Assembly	"Y" Connector-Assembly		As required
20	TJ222	Ø32mm Hose		As required
21	TJ223	Clamp Assembly		As required
22	TJ224	Spreader Plate Assembly		As required
23	TJ227	Ø40mm BZP Hose Clip		As required
24	TJ038	Strip Seal	2.4m	
25	TJ021A	Agitator Paddle (8 outlet)	4	
Or	TJ021A	Agitator Paddle (10 outlet)	5	

24.1 Turbo Jet Parts List - continued

Item	Part No.	Description	Qty.	Remarks
26	TJ137	Coupler	1	
27	TJ131	4mm Allen Key	1	
28				
29	TJ416	Cassette Mounting Plate	1	
30				
31	TJ128	Hopper Lid	1	
32	TJ129	Neck Ring	1	
33	TJ130	PVC Calibration Tray	1	
34	FJ033A	M8 Fem Knob	3	
35	GRO03	Rubber Grommet	2	
36	TJ053	Rubber Washer	1	
37	TJ054	Rubber Washer	1	
38				
39	GA046B	Agitator Motor	1	
40				
41	TJ040	Feed Block Gasket	1	
42	TJ041	Junction Box Gasket	1	
43				
44	GA103	PVC Flanged Bush	6	
45	TJ055-1	Chassis PVC Blank Plug (Agitator shaft)	1	Not shown
46				
47	TJ430	Hinge Guard (8 outlet)	1	
	TJ431	Hinge Guard (10 outlet)	1	
48	TJ044B	Feed Motor	1	
49	TJ039	Rubber Grommet	1	
50	TJ043A	Coupler	1	
52	FJ419A	R' Clip	4	
53	M6-003	M6 Setscrew	2	
54	M6-016	M6 Flat Washer	2	
55	M5-011	M5 Setscrew	4	
56	M5-014	M5 Flat Washer	4	
57	M6-004	M6x16 Bolt	2	
58	M6-004	M6x16 Bolt	3	
59	M6-007	M6x20 CSK Setscrew	4	
60	M6-016	M6 Flat Washer	6	
61	M6-008	M6x25 Button Head Setscrew	4	
62	M8-004	M8x20 Dome SQ Bolt	16	
63	M8-010	M8 Flat Washer	16	

24.1 Turbo Jet Parts List-continued

Item	Part No.	Description	Qty.	Remarks
64	M8-012	M8 Penny Washer	2	
65	M10-001	M10x16 Bolt		As required
66	M4-004	M4 Lock Nut	4	
67	M10-016	M10 Flat Washer		As required
68	M10-024	M10 Lock Nut	3	
69	M12-003	M12x35 Bolt	4	
70	M12-008	M12 Flat Washer	8	
71	M12-014	M12 Lock Nut	4	
72	M4-001	M4x6 Socket Head Setscrew	8	
73	M4-006	M4 Flat Washer	8	
74	M8-019	M8 Lock Nut	16	
75	TJ150	`C' Rail 2 metre length		As required
76	TJ151A	Channel Nut		As required
77	TJ152-1	Short Clamp Plate 2 Holes		As required
78	TJ153	Long Clamp Plate 3 Holes		As required
79	TJ050	Tank Outlet	1	
80	TJ051	Nut	1	
81	TJ052	Blanking Cap	1	
82	TM016	Jackal Hopper Level Sensor	1	
83	M4-006	M4 Flat Washer	8	
84	M4-003	M4 Setscrew	8	
85	M8-019	M10 Lock Nut	1	
86	TJ1285	Self Tapping Screw	1	
87	M5-015	Washer	1	
88	MM019	Loop Link Chain	1	
89	TJ471	Hopper Baffle Plate (8 outlet)	1	400L models only
Or	TJ472	Hopper Baffle Plate (10 outlet)	1	400L models only
90	TJ196A	8 Outlet Feed Block Assembly		
	TJ196E	10 Outlet Feed Block Assembly		
	TJ196B	8 Outlet Low Rate Feed Block Assembly		
	TJ196F	10 Outlet Low Rate Feed Block Assembly		
93	TJ435A	Door Release Shaft TJ8	1	
	TJ440A	Door Release Shaft TJ10	1	
94	TJ437A	Door Latch	1	
95	TJ433	E-Clip	1	
96	FJ418A	Split Ring	1	
100	M3-003	M3 Bolt	1	
101	M3-008	M3 Lock Nut	1	
Jackal Control System:				
123	TJ255B	GPS Receiver		
125		Mounting Kit for Instrument Panel	1	
126	97APC0046	Jackal Instrument Panel c/w Mounting Kit	1	
127		Junction Box	1	
129	TJ252	Finger Switch		
130	TJ253	Finger Switch Mounting Plate		
131	TJ254	5m Finger Switch Cable		
132	TJ238	5m Fused Power Cable	1	Not shown
133	97APC0051	5m Instrument Cable	1	Not shown

25.0 Feed Roller Kit Parts Diagram

Turbo Jet 8 Outlet

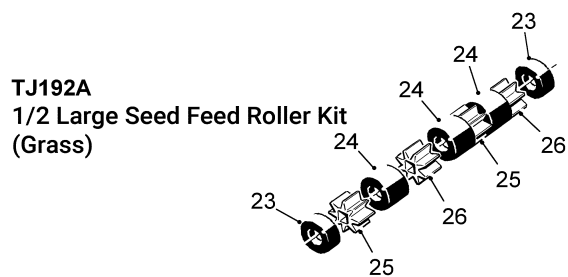
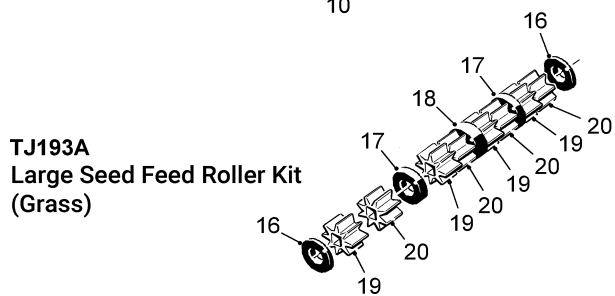
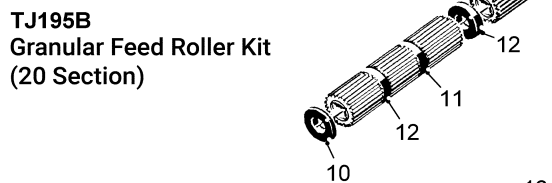
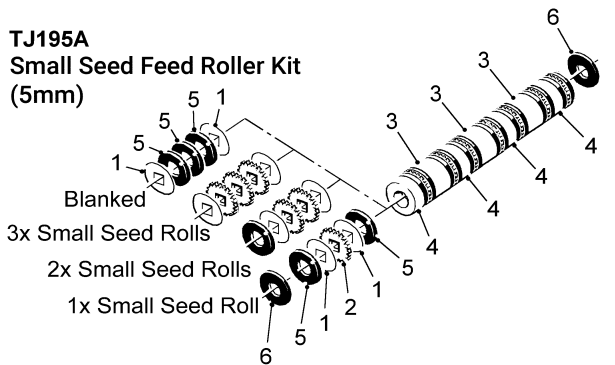

Turbo Jet 10 Outlet

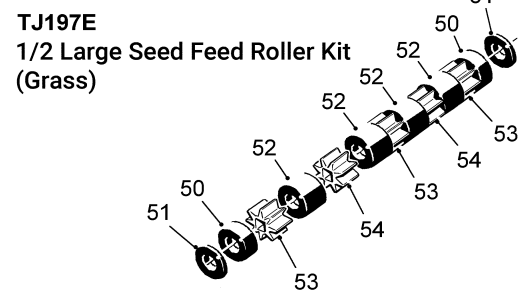
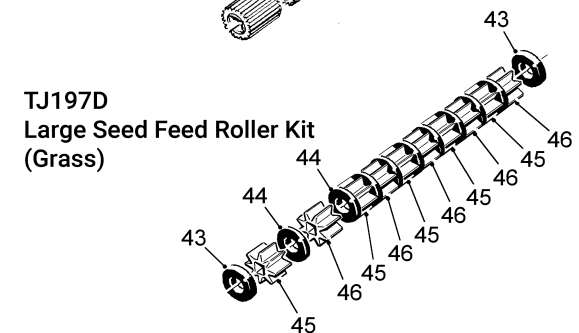
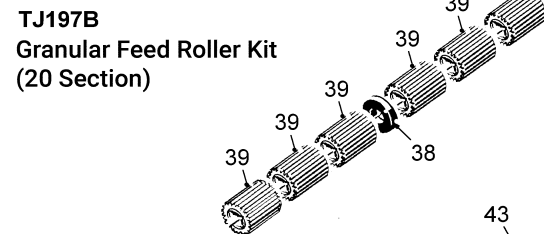
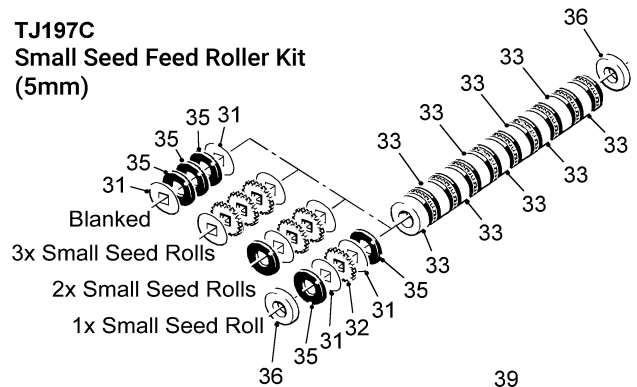

TJ-SP015

Large Seed Feed Rollers (Grass)

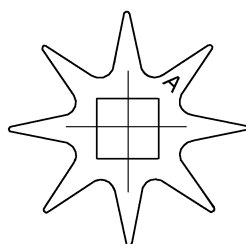

Part No. GA110B-A

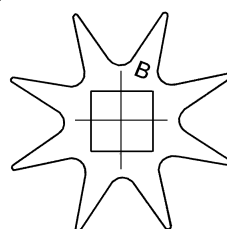

Part No. GA110B-B

25.1 Feed Roller Kits Parts List

Item	Part No.	Description	Qty.	Remarks
	TJ195A	8 Outlet 5mm Small Seed Feed Roller Kit:		
1	TJ199	Stainless Steel Shim	16	
2	TJ200	5mm Small Seed Roll (White)	16	
	TJ201	5mm Small Seed Roll (Yellow)	8	
3	TJ203	24.6mm Spacer	3	
4	TJ204	13.5mm Spacer	4	
5	TJ205	5mm Spacer	19	Includes 3 spare
6	TJ207A	3mm Spacer	2	
7	TJ219-1	PVC Manifold Blanking Plug	3	Not shown
	TJ195B	8 Outlet 20 Section Seed Feed Roller Kit:		
10	TJ207A	3mm Spacer	2	
11	TJ208	10mm Spacer	1	
12	TJ212	12.25mm Spacer	2	
13	GA110	20 Section Feed Rollers	4	
	TJ193A	8 Outlet Seed Feed Roller Kit:		
16	TJ207A	3mm Spacer	2	
17	TJ208	10mm Spacer	2	
18	TJ204	13.5mm Spacer	1	
19	GA110B-A	8 Section Grass Seed Roller (A)	4	
20	GA110B-B	8 Section Grass Seed Roller (B)	4	
	TJ192A	8 Outlet Half Seed Feed Roller Kit:		
23	TJ209	15.4mm Spacer	2	
24	TJ213	39.5mm Spacer	3	
25	GA110B-A	8 Section Grass Seed Roller (A)	2	
26	GA110B-B	8 Section Grass Seed Roller (B)	2	

25.1 Feed Roller Kits Parts List - continued

Item	Part No.	Description	Qty.	Remarks
	TJ197C	10 Outlet 5mm Small Seed Feed Roller Kit:		
31	TJ199	Stainless Steel Shim	20	
32	TJ200	5mm Small Seed Roll (White)	20	
32	TJ201	5mm Small Seed Roll (Yellow)	10	
33	TJ210	18mm Spacer	9	
35	TJ205	5mm Spacer	23	Includes 3 spare
36	TJ211	6.5mm Spacer	2	
36a	TJ219-1	Manifold Blanking Plug	3	Not shown
	TJ197B	10 Outlet 20 Section Seed Feed Roller Kit:		
38	TJ207A	3mm Spacer	1	
39	GA110	20 Section Seed Roll	5	
	TJ197D	10 Outlet Seed Feed Roller Kit:		
43	TJ211	6.5mm Spacer	2	
44	TJ214	5.3mm Spacer	9	
45	GA110B-A	8 Section Grass Seed Roller (A)	5	
46	GA110B-B	8 Section Grass Seed Roller (B)	5	
	TJ197E	10 Outlet 1/2 Grass Seed Feed Roller Kit:		
50	TJ209	15.4mm Spacer	2	
51	TJ205	5mm Spacer	2	
52	TJ213	39.5mm Spacer	4	
53	GA110B-A	8 Section Grass Seed Roller (A)	3	
54	GA110B-B	8 Section Grass Seed Roller (B)	2	

26.0 Hydraulic Fan - Parts (Diagram)

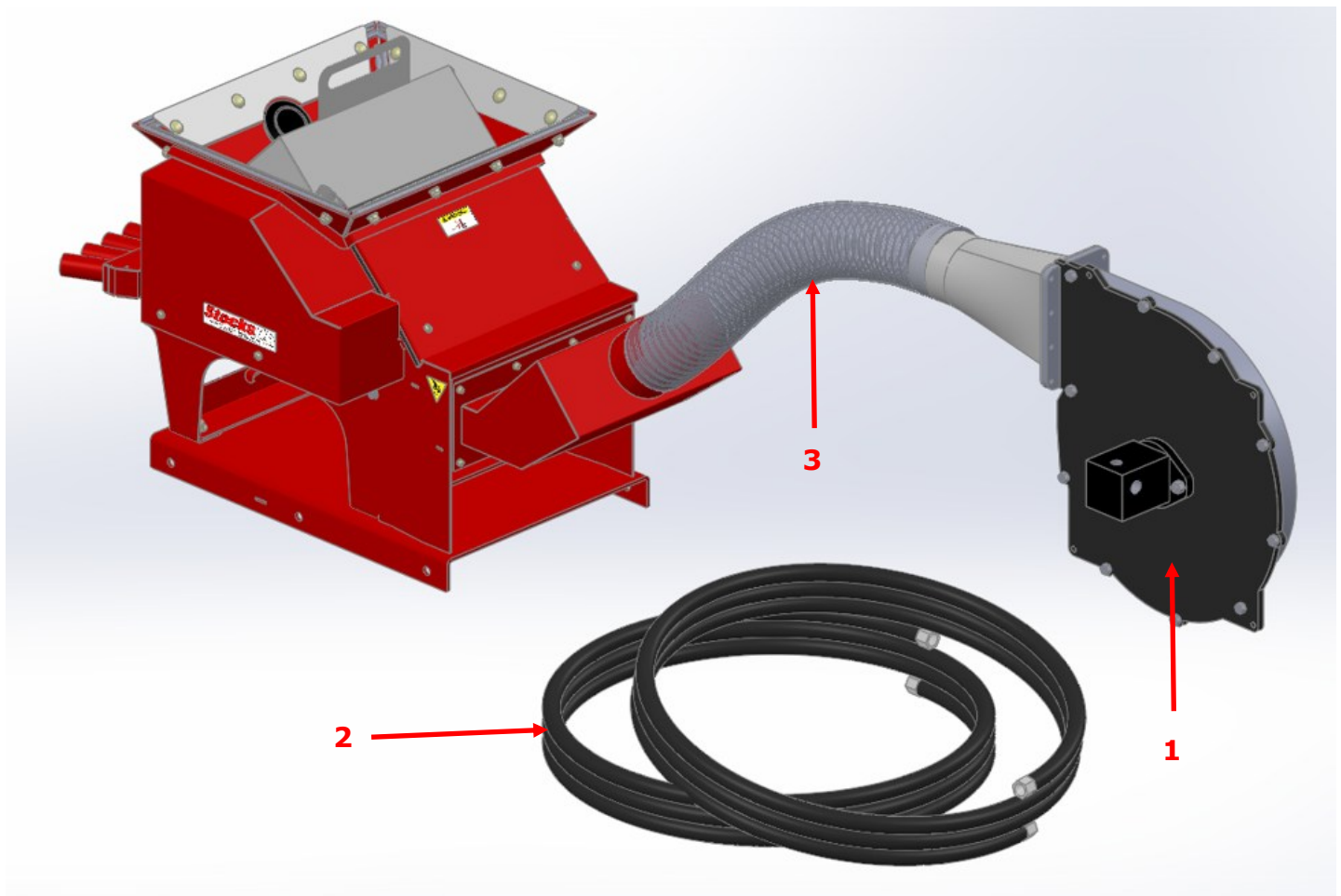

26.0 Hydraulic Fan - Parts List

Item	Part Number:	Description	Qty
1	97APC5452	CRARY HYDRAULIC FAN	1
2	97APC5454	HYDRAULIC FAN HOSE KIT (Pair)	1
3	97APC5456	4 INCH PVC DUCTING	1

27.0 Turbo Jet Hydraulic Version - Parts (Diagram)

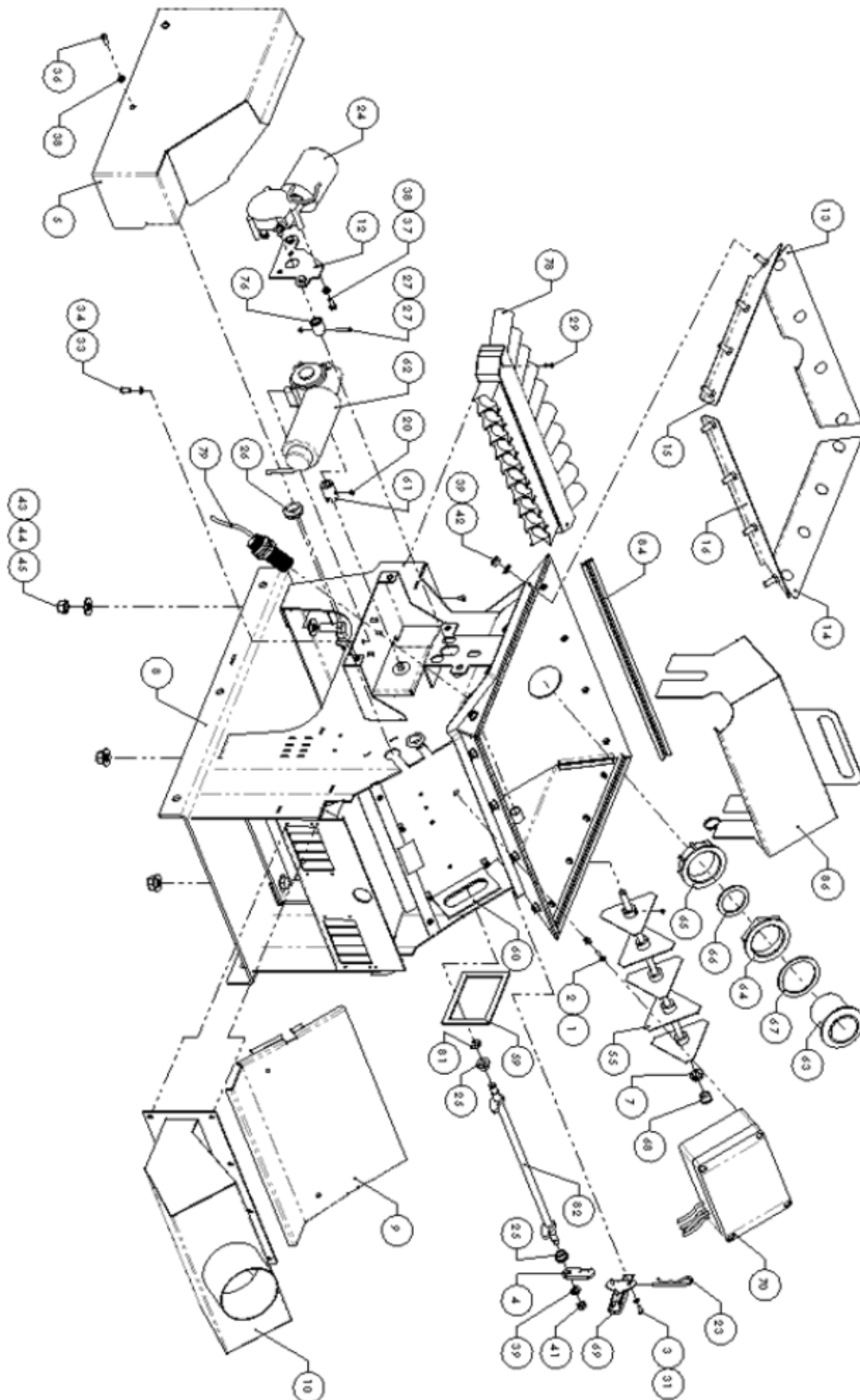

27.1 Turbo Jet Hydraulic Version - Parts List

ITEM NO	PART NUMBER	DESCRIPTION	QTY
1	89APP1011	JETPRESS CAN 015 SQUARE HEADED SCREW GROMMET	7
2	89APP1012	NO. 8 x 1" POZI SELF TAPPING PAN HEAD SCREW ST-ST	4
3	89APP1015	NO. 8 HALF INCH POZI SELF TAPPING PAN HEAD SCREW ST-ST	9
4	97APC1432	DOOR LATCH CATCH PLATE	1
5	97APC1433	MOTOR GUARD WELD ASSEMBLY	1
7	97APC1462	CHASSIS WELD ASSEMBLY - 2ND STAGE	1
8	97APC5133	BASE PLATE	1
9	97APC5140	REAR COVER AND GUARD	1
10	97APC1444	AIR BOX WELD ASSEMBLY	1
11	97APC5149	BASE PLATE WELD ASSEMBLY	1
12	97APC5170	AGITATOR PLATE	1
13	97APC5177	HOPPER DOUBLER PLATE MANIFOLD SIDE WELD ASSEMBLY	1
14	97APC5178	HOPPER DOUBLER PLATE CASSETTE SIDE WELD ASSEMBLY	1
15	97APC5179	HOPPER DOUBLER PLATE MOTOR SIDE WELD ASSEMBLY	1
16	97APC5180	HOPPER DOUBLER PLATE FAN SIDE WELD ASSEMBLY	1
17	98APP1024	TURBO JET DECAL	2
18	98APP1025	STOCKS AG DECAL	1
19	98APP1025	STOCKS AG DECAL	1
20	FJ008A	M6 x 6 CONE POINT HEX SOCKET GRUB SCREW ST/ST	1
21	FJ033A	M8 FEMALE PLASTIC KNOB - BLACK	2
22	FJ418A	SPLIT RING	1
23	FJ419A	R PIN	3
24	GA046	AGITATOR MOTOR 12VDC	1
25	GA103	FLANGED PVC BUSH	2
26	GR003	GROMMET	2
27	M3-003	M3 x 25 HEX HEAD SET SCREW ST/ST	1
28	M3-008	M3 NYLOC NUT T TYPE ST/ST	1
29	M4-001A	M4 x 12 BUTTON SOCKET HEAD SET SCREW ST/ST	2
30	M4-003	M4 x 10 SOC CAP HEAD SET SCREW ST/ST	4
31	M4-006	M4 FLAT WASHER FORM A ST/ST	13
32	M5-001	M5 x 8 HEX SOCKET BUTTON HEAD SCREW ST/ST	2
33	M5-004	M5 x 12 HEX HEAD SET SCREW ST/ST	4
34	M5-014	M5 FLAT WASHER FORM A ST/ST	4
35	M5-015	M5 REPAIR WASHER BZP	1
36	M6-003	M6 x 16 HEX SOCKET BUTTON HEAD SET SCREW ST/ST	4

27.1 Turbo Jet Hydraulic Version - Parts List continued

ITEM NO	PART NUMBER	DESCRIPTION	QTY
37	M6-004	M6 x 16 HEX HEAD SET SCREW ST/ST	5
38	M6-016	M6 FLAT WASHER FORM A ST/ST	9
39	M8-010	M8 FLAT WASHER FORM A BZP	17
40	M8-012	M8 REPAIR WASHER BZP	2
41	M8-014	M8 NUT BZP (M8-014)	1
42	M8-019	M8 NYLOC NUT T TYPE BZP	16
43	M12-004	M12 x 35 BZP HEX HEAD SET SCREW	4
44	M12-008	M12 FLAT WASHER FORM C BZP	8
45	M12-014	M12 NYLOC NUT T TYPE BZP	4
46	MD021	ROTATION ARROW DECAL	1
47	MD024	"MADE IN BRITIAN` DECAL	1
48	MD027	STOCKS AG DECAL	1
49	MD038	SERIAL NO DECAL	1
50	MD051	WARNING DECAL	1
51	MD051	WARNING DECAL	1
52	MD051	WARNING DECAL	1
53	MD051	WARNING DECAL	1
54	MM019	LOOP LINK CHAIN	1
55	TJ021A	AGITATOR PADDLE ASSEMBLY	5
56	TJ038	STRIP SEAL	1
57	TJ038	STRIP SEAL	1
58	TJ038	STRIP SEAL	2
59	TJ040	SELF ADHESIVE FEED BLOCK GASKET	1
60	TJ041	SELF ADHESIVE JUNCTION BOX GASKET	1
61	TJ043A	MOTOR DRIVE COUPLING - SLOTTED	1
62	TJ044B	12 VDC FEED MOTOR	1
63	TJ050	TANK OUTLET FOR DRAIN BUNG	1
64	TJ051	PVC NUT FOR DRAIN BUNG	1
65	TJ052	BLANKING CAP FOR DRAIN BUNG	1
66	TJ053	RUBBER GASKET FOR BLANK CAP	1
67	TJ054	RUBBER GASKET FOR DRAIN BUNG	1
68	TJ055-1	PVC BLANKING PLUG	1
69	TJ103	OVER CENTRE LATCH	1
70	TJ119D	JUNCTION BOX MKII	1
72	TJ126A	HOPPER 240L	1
73	TJ128	LID	1
74	TJ129	NECK RING	1
75	TJ130	PVC CALIBRATION TRAY	1
76	TJ137	AGITATOR DRIVE SHAFT COUPLER	1
77	TJ138A	AGITATOR SHAFT	1
78	TJ217A	10 OUTLET FEED MANIFOLD ASSEMBLY	1
79	TJ251A	HOPPER LEVEL SENSOR	1

27.1 Turbo Jet Hydraulic Version - Parts List continued

ITEM NO	PART NUMBER	DESCRIPTION	QTY
81	TJ433	E TYPE CLIP	1
82	TJ440A	DOOR RELEASE SHAFT WELD ASSEMBLY	1
83	TJ467-1	WHITE `P` SEAL STRIP	4
84	TJ467-1	WHITE `P` SEAL STRIP	2
85	TJ467-1	WHITE `P` SEAL STRIP	2
86	TJ472A	HOPPER BAFFLE WELD ASSEMBLY	1
87	TJ1285	NO.10 x 1 INCH HEX HEAD SELF TAPPING SCREW ST/ST	1

