



***Stocks*AG**

Turbo Jet 8 & 10 i-CON

ORIGINAL OPERATING MANUAL & PARTS LIST



Read carefully before installation and operation

This document must not be copied duplicated or distributed without prior consent.
All intellectual property and patent rights apply.



Stocks Ag Limited.

Cromwell Road, Wisbech, Cambridgeshire, PE14 0SD, UK
01945 464909 sales@stocks-ag.co.uk www.stocks-ag.co.uk



Index

Section		Page
	E.C. DECLARATION OF CONFORMITY	5
	UKCA. DECLARATION OF CONFORMITY	6
1.0	General Information	7
1.1	Technical Data	7
1.2	Intended Use	7
1.3	Unintended Use	7
1.4	Machine Identification	8
1.5	Warranty	8
2.0	Safety	9
2.1	Safety Warning Decals	10
3.0	Emergency Stop Instructions	11
4.0	Storage	11
5.0	PVC Waterproof Covers	11
6.0	Disposal	11
7.0	General Maintenance	12
7.1	Before Use	12
7.2	Daily Checks	12
7.3	After Each Use	12
8.0	Installation Guide	13
8.1	Base Plate	13
8.2	Spreader Plates	14
8.3	Spreader Plates Set Up	14
8.4	C Section Rail	16
8.5	Feed Hose	16
9.0	Machine Components	17
9.1	Feed Motor	17
9.2	Hopper Agitator	17
9.3	12v Fan Unit	17
9.4	Main Power Cable	17
9.5	Instrument Lead	17
9.6	Spring Finger Switch	17
9.7	Junction Box	18

Index

Section	Page	
9.8	i-CON Instrument	18
9.9	Hopper Level Sensor	18
9.10	Feed Rollers	18
10.0	Inspection	19
10.1	Fan Inspection	19
10.2	Feed Block Assembly Inspection	19
10.3	Agitator Shaft Inspection	19
11.0	Hopper Emptying Procedure	20
12.0	Clearing A Feed Hose Blockage	20
13.0	Checking The Feed Motor	20
14.0	i-CON Control System	21
14.1	i-CON Overview	21
14.2	Wiring Diagram	21
14.3	i-CON Instrument Functions	22
14.4	Precision Farming Software Access	22
15.0	i-CON Calibration	23
15.1	At The Junction Box	23
15.2	At The i-CON Cab Console	23
15.3	Manual Calibration	24
15.4	GPS Speed	24
15.5	Common Calibration Mistakes	24
15.6	Ready For Work	24
16.0	Feed Block Assembly Guide	25
16.1	Feed Roller Configuration	25
16.2	Feed Block Assemblies	26
16.3	Feed Block Assemblies - Optional	26
17.0	Hopper Baffle Plate	26
18.0	Hydraulic Fan (Optional) Specification	27
18.1	Hydraulic Fan - Safety	28
18.2	Hydraulic Fan - Fitting Position	28
18.3	Hydraulic Fan - Speed Setting	29
18.4	Hydraulic Fan - Speed Guide	29
18.5	Hydraulic Fan - Speed Display	30
18.6	Hydraulic Fan - Speed Sensor	30

Index

Section		Page
18.7	Hydraulic Fan - Mounting	31
19.0	Turbo Jet Parts (Diagram)	32
19.1	Turbo Jet Parts List	33
19.2	Turbo Jet Parts List	34
19.3	Turbo Jet Parts List	36
19.4	Turbo Jet Parts List	36
20.0	Feed Roller Kit Parts (Diagram)	37
20.1	Feed Roller Kits Parts List	38
20.2	Feed Roller Kits Parts List Continued	39
21.0	Hydraulic Fan - Parts (Diagram)	40
21.1	Hydraulic Fan - Parts List	40
22.0	Turbo Jet Hydraulic Version - Parts (Diagram)	41
22.1	Turbo Jet Hydraulic Version - Parts List	42
22.2	Turbo Jet Hydraulic Version - Parts List Continued	43
22.3	Turbo Jet Hydraulic Version - Parts List Continued	44



E.C. DECLARATION OF CONFORMITY

Machine Type: Mounted Agricultural Implement - Pellet and Seed application broadcasters

Model(s):	Fan Jet Pro	All Variants and Versions
	Fan Jet Plus	All Variants and Versions
	Fan Jet Mini	All Variants and Versions
	Fan Jet Duo	All Variants and Versions
	Maxi Jet	All Variants and Versions
	Turbo Jet	All Variants and Versions
	Rotor Meter	All Variants and Versions
	Rotor Jet	All Variants and Versions
	Micro Meter	All Variants and Versions
	Maxi Meter	All Variants and Versions

Serial No.

Manufacturer: Stocks Ag Ltd
Cromwell Road
Wisbech
Cambridgeshire PE14 OSD
United Kingdom

This is to declare that the above machine conforms to the relevant Essential Health and Safety Requirements of the Machinery Directive 2006/42/EC, implemented in the United Kingdom by Statutory Instrument 2008 No. 1597 – The Supply of Machinery (Safety) Regulations 2008 as amended.

The following standards have been applied in the design and construction of this machine:

- | | | |
|-------------------|------|--|
| BS EN ISO 12100: | 2010 | Safety of machinery – General principles for design – Risk assessment and Risk reduction. |
| BS EN ISO 4254-1: | 2015 | Agricultural machinery – Safety - General requirements. |
| BS EN ISO 4254-8: | 2018 | Agricultural machinery. Safety - Solid fertiliser distributors. |
| BS EN ISO 13854: | 2019 | Safety of machinery – Minimum gaps to avoid crushing of parts of the human body. |
| BS EN ISO 13857: | 2019 | Safety of machinery – Safety distances to prevent hazard zones being reached by the upper and lower limbs. |

The manufacturer stated above holds the technical file for this machine.

Signed on behalf of Stocks Ag Ltd

Name:  J Woolway

Date: 06th August 2020

Position: Managing Director



t. +44 (0) 1945 464909 f. +44 (0) 1945 464985 e. sales@stocks-ag.co.uk

StocksAG**UKCA. DECLARATION OF CONFORMITY**

Machine Type: Mounted Agricultural Implement - Pellet and Seed application broadcasters

Model(s):	Fan Jet Pro	All Variants and Versions
	Fan Jet Plus	All Variants and Versions
	Fan Jet Mini	All Variants and Versions
	Fan Jet Duo	All Variants and Versions
	Maxi Jet	All Variants and Versions
	Turbo Jet	All Variants and Versions
	Rotor Meter	All Variants and Versions
	Rotor Jet	All Variants and Versions
	Micro Meter	All Variants and Versions
	Maxi Meter	All Variants and Versions

Serial No.

Manufacturer: Stocks Ag Ltd
Cromwell Road
Wisbech
Cambridgeshire PE14 OSD
United Kingdom

This is to declare that the above machine conforms to the relevant Essential Health and Safety Requirements of the Machinery Directive 2006/42/EC, implemented in the United Kingdom by Statutory Instrument 2008 No. 1597 – The Supply of Machinery (Safety) Regulations 2008 as amended.

The following standards have been applied in the design and construction of this machine:

BS EN ISO 12100:	2010	Safety of machinery – General principles for design – Risk assessment and Risk reduction.
BS EN ISO 4254-1:	2015	Agricultural machinery – Safety - General requirements.
BS EN ISO 4254-8:	2018	Agricultural machinery. Safety - Solid fertiliser distributors
BS EN ISO 13854:	2019	Safety of machinery – Minimum gaps to avoid crushing of parts of the human body.
BS EN ISO 13857:	2019	Safety of machinery – Safety distances to prevent hazard zones being reached by the upper and lower limbs.

The manufacturer stated above holds the technical file for this machine.

Signed on behalf of Stocks Ag Ltd

Name:  J WoolwayDate: 01st December 2020

Position: Managing Director

t. +44 (0) 1945 464909 f. +44 (0) 1945 464985 e. sales@stocks-ag.co.uk**UK
CA**

1.0 General Information

Congratulations on your Turbo Jet purchase:

Please check the machine for any transport damage upon receipt and advise your supplier of any problems immediately. Late claims regarding any damage may be rejected.

Specifications descriptions and illustrations in this manual are accurate at the time of this publication but may be subject to change this manual are correct at the time of printing but we reserve the right to change and improve them. This machine is designed with safety in mind. Maintenance and servicing in accordance with this manual will ensure safe operation and reliability of your machine for many years.

IMPORTANT: This Operating Manual forms part of the machine and must be readily available for the operator who must read and follow the points covered before use.

1.1 Technical Data

Model: Turbo Jet 8 i-CON and Turbo Jet 10 i-CON

Hopper capacity: 240 litre or 400 litre.

240 litre machine:

Net weight: 90kg with spreader kit 120kg,

Dimensions: (WxDxH) 66x100x116cm.

Max. spreading width:

Turbo Jet 8: 8m

Turbo Jet 10: 10m electric fan

Turbo Jet 10: 15m hydraulic fan (product dependant)

400 litre machine:

Net weight: 95kg with spreader kit 130kg,

Dimensions: (WxDxH) 66x100x143cm.

Recommended working width:

Turbo Jet 8: 3-8m

Turbo Jet 10: 3-10m - depending on the application

Turbo Jet 10: 15m hydraulic fan (product dependant)

Operating voltage 12v: power requirement 30 amps, motor output 360 watt

Power consumption of the motor: 35 amps when starting, up to 30 amps during normal operation

Noise level: 70 dB electric fan - 90dB hydraulic fan (optional)

1.2 Intended Use

This Turbo Jet has been designed solely to apply small seed and granular products for use in the agricultural, horticulture and the amenity sector.

Any other use is considered to be non-intended and the manufacturer will not be liable for any resulting damage.

This machine should not be used in the rain or during a thunderstorm.

The manufacturer is not liable for any resulting damage if the machine is used for any other purpose than the intended use and also includes compliance with the conditions for operation, maintenance, and repairs prescribed within this instruction manual.

The applicable accident prevention regulations as well as the other generally safety-related, occupational health and road traffic regulations must also be observed.

NOTE: Do not operate this machine during adverse weather conditions.

1.3 Unintended Use

This machine is not designed to apply abrasive materials such as sand & grit or for applying salt products.

The operator alone bears the associated risk if used for non-intended use.

2.0 Safety

Ensure care is taken when lifting the machine. Safe lifting practice to be observed when handling as the net weight is over 25kg.



- We advise safety shoes and protective gloves are worn when handling the machine.
- Assistance will be required when lifting or lowering the machine.
- Care to be taken to avoid crushing due to the weight of the machine.
- When lifting or fitting the machine on to a parent vehicle or implement ensure work is performed on level ground or flat surface to avoid slipping, stumbling or falling.

PERSONAL PROTECTION EQUIPMENT

It is the responsibility of the operator or maintenance engineer to ensure safe handling of the machine and the appropriate personal protection equipment must be worn for the material being applied and to prevent contamination to the machine or the environment.

⚠ WARNING! Ear protection required if working in close proximity to the machine as it exceeds 80dB.

PRODUCT APPLIED

If applying slug pellets or other toxic material and the parent vehicle has a closed cab the operator must ensure the cabin is always closed and the air filter system is in good order. If fitted to a UTV vehicle ensure the stability of the parent vehicle is not affected when the machine is in use. If in doubt contact the vehicle manufacturer for more information. After working the machine ensure that any unused product is returned safely to its original packaging. Stocks Ag Ltd. does not accept any liability for the storage and use of the material being applied.

NOTE: If unsure contact your seed or product supplier for more information.

⚠ WARNING! Always observe all application standards and guidelines provided by the product manufacturer as some seed dressings and granular products may be toxic.

OPERATION AND MAINTENANCE

The machine may only be used, maintained and repaired by persons who have relevant experience or a machinery dealer who is aware of any risks involved. The applicable accident prevention regulations as well as the other generally safety related, occupational health and road traffic regulations must also be observed.

The manufacturer is not liable for any damage resulting from unauthorised modifications and the use of components and auxiliary parts. The machine must be checked regularly by the operator (before each use) for any damage, loose bolts or electrical connections, vibrations, unusual sounds, and to ensure they function correctly.

The machine must not be operated in wet weather conditions or during thunderstorms. Observe the generally applicable safety and accident prevention regulations. Always empty the hopper of toxic materials to prevent harm to humans and animals after each use and prior to storage.

⚠ WARNING! Do not put your hands inside the hopper when the agitator motor is turning as the agitator shaft inside the hopper rotates at high speed and is sharp and dangerous.

⚠ WARNING! Always isolate the power supply if servicing or leaving the machine unattended.

2.1 Safety Warning Decals

Important: Be aware of the safety warning below which are all relevant to this machine



⚠ WARNING!

Read and understand the Operators Manual instructions before operating this machine.

Operator errors can result in serious injury.



⚠ WARNING!

Danger due to thrown or flying objects.

Always maintain a safe distance whilst the machine is in operation.

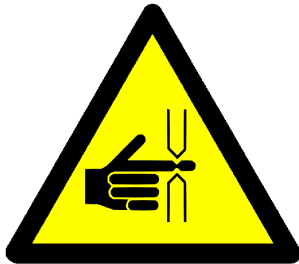

⚠ WARNING!

Risk of injury. Possible trapping point when tipping hopper.



⚠ WARNING!

Risk of injury.

Be aware the feed mechanism is powerful and can cause serious injury.



⚠ WARNING!

Keep Clear!

Maintain a safe distance from the machine when in operation.

Wear the appropriate protective personal equipment.



⚠ WARNING!

Do Not Jet Wash This machine is not designed to withstand Jet Washing.

3.0 Emergency Stop Instructions

1. Power down the control system immediately by pressing and holding down the left-hand rubber end cap on the instrument control panel for approx. 2 seconds — then release to power off.



4.0 Storage

2. Disconnect the power supply by unplugging the power cable or by removing the 40amp fuse fitted in the power cable.

It is the responsibility of the operator to ensure the hopper is empty after use and cleaned thoroughly before storage.

Store in dry conditions to protect the machine and control system from moisture.

Always clean and spray electrical connectors with a moisture repellent spray when not in use for long periods.

Fit the PVC waterproof cover (if available).

Ensure feed blocks are free to turn and all electrical cables checked following periods of storage.

5.0 PVC Waterproof Covers - Optional

Heavy Duty White PVC covers available for both the 240L and 400L machines, fitted with eyelets and bungee cord for easy attachment.

240L Model TJ240COVER 400L Model TJ400COVER

Please contact your locals Stocks Ag dealer for more information.

6.0 Disposal

Ensure that any persons handling the machine are aware that the machine may have been used to apply toxic chemicals and so the appropriate personal protection equipment should be worn.

Ensure the hopper contents have been removed and any toxic residue removed and put back into a sealed container or disposed of in accordance with the manufacturers guidelines to eliminate any possible contamination of others or the environment.

Always adhere to the local disposal regulations paying particular attention to the plastics, rubber, and electrical components.

7.0 General Maintenance

⚠ WARNING! Always ensure the power supply is disconnected before any maintenance work or cleaning of this machine by unplugging the power cable or removing the 40amp fuse in the power cable.

Ensure the parent machine is stationary and parked on level ground before working on the machine.

The machine must be checked regularly by the operator for any damage loose bolts or electrical connections, vibrations, unusual sounds, and to ensure they function correctly.

⚠ WARNING! Protective clothing must be worn when applying or handling toxic products.

Always observe all guidelines provided by the product manufacturer with regards to handling, storage and disposal of products. Take care not to spill any product that could contaminate the machine or the environment ensuring any product removed from the machine is put back into its original container.

7.1 Before Use

1. Ensure the machine is securely mounted.
2. Check the power supply and ensure the power cable is connected direct to the vehicle battery.
3. Check the feed block is configured correctly and free running before starting work.

7.2 Daily Checks

1. Check the feed motor and agitator motors are working correctly.
2. Check the 12v Fan and air intake meshes are clean and free from any debris.
3. Check feed hoses for any blockages and all hose clips are tight.
4. Check the spreader plates are positioned correctly.

7.3 After Each Use

1. Empty hopper and clean the machine thoroughly.
2. Disconnect the power supply.
3. Replace the PVC waterproof cover (if applicable).
4. Store in dry conditions to protect the machine and control system from moisture.

⚠ WARNING
DO NOT JET WASH THIS MACHINE.



8.0 Installation Guide

The Turbo Jet can be used for a wide variety of seeding applications in conjunction with a wide variety of parent implements.

It is not practical to supply tailored mounting brackets for every implement on the market, and so the final attachment of the Turbo Jet to the implement is the responsibility of the supplying dealer or end user.

The positioning of the hopper, the spreader plate, the "C" section mounting rails will depend upon the type and design of parent implement, here are a few basic pointers to ensure the Turbo Jet performs correctly.

Position the Turbo Jet high enough above the implement to facilitate routing of the flexible tubes to the spreader plates, without severe bends or uphill runs. Try to route all tubes generally downhill. Do not block the air intakes to the fans under the base plate.

Ensure the wing sections do not foul the hopper and all hose runs are long enough to fold with the implement, and the tubes are long enough to fold with the implement, without a restriction when in work.

Ensure you can access the hopper to fill, and are able to remove the feed block assembly and position the calibration tray underneath to calibrate or empty.

Ensure there is room to undo the fan housing catches and lift the housing to clean the fans. When filling, emptying or calibrating the Turbo Jet ensure you work safely. If necessary fabricate and fit a work platform and steps, complete with handrails. The hopper may face forwards or backwards- whichever offers the easiest mounting and best flexible tube run. Select a strong, rigid position and use the heavy flat base plate provided to weld or bolt to your implement as per the below example. If necessary fabricate and fit a work platform and steps, complete with handrails.



8.1 Base Plate

Part No. TJ422 - Dimensions and fixing hole detail

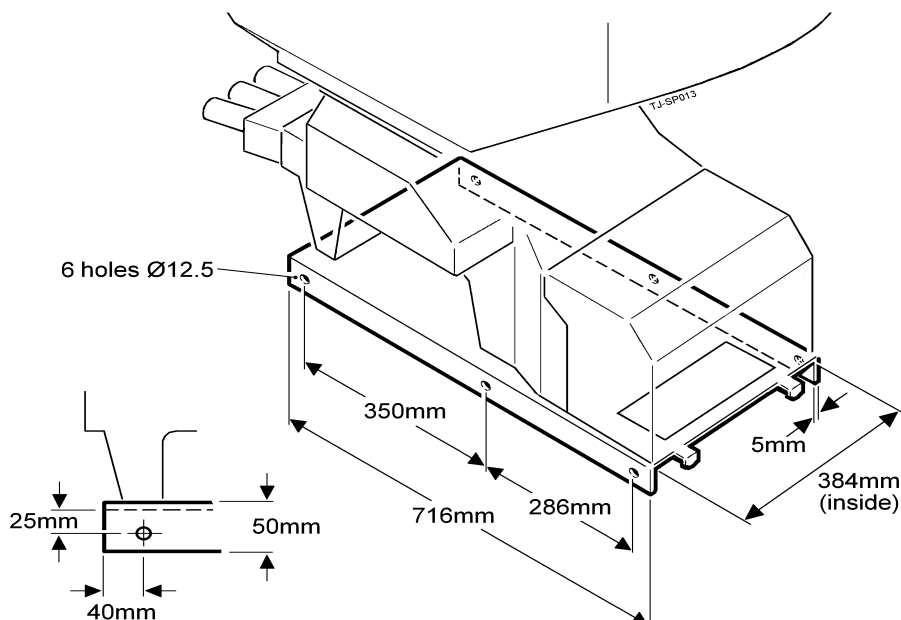

8.2 Spreader Plates

The machines have 8 or 10 outlets, if required the feed hoses can be split with the black "Y" connectors in the relevant kits, to give 16 or 20 spreader plates. Depending on the implement width and if you require a broadcast or band sown effect, use as many outlets as required.

Plan the positioning of the pipes/spreader plates to be equal distant across the width of your implement. If using the black plastic "Y" connectors ensure they are fitted above the spreader plate using as short a run of flexible hose to the plates as possible, whilst still providing a smooth flow and of being equal length. It is recommended that a straight of a minimum 300mm section of pipe is utilised prior to the "Y" connector, to ensure a more even split of product. Flexible hoses from these connectors then runs to the outlet pipes on the Turbo Jet. Aim to route all these hoses smoothly and generally downhill from the hopper to the spreader plate, avoiding severe bends and uphill runs.

8.3 Spreader Plate Set Up

The Stocks Ag spreader plate was developed to allow a wider spread pattern while positioning the outlets closer to the ground.

For products such as grass seed, oil seed rape and Avadex, a spread width per outlet of 750mm is achievable from as low as 250mm above the ground (250mm to the bottom plate).

A 6m grass harrow only requires 8 evenly spaced outlets. In many circumstances reducing the need for Y piece splitters and having double the outlets.

The spreader plates have two main adjustments to set up the optimum spread pattern to suit a variety of products and machine fitments.

The main bottom plate requires bending into position. The angle of the bottom plate alters the spread width from each outlet. A common setup would be to bend from vertical to approximately 15° from parallel to the top plate (see below).

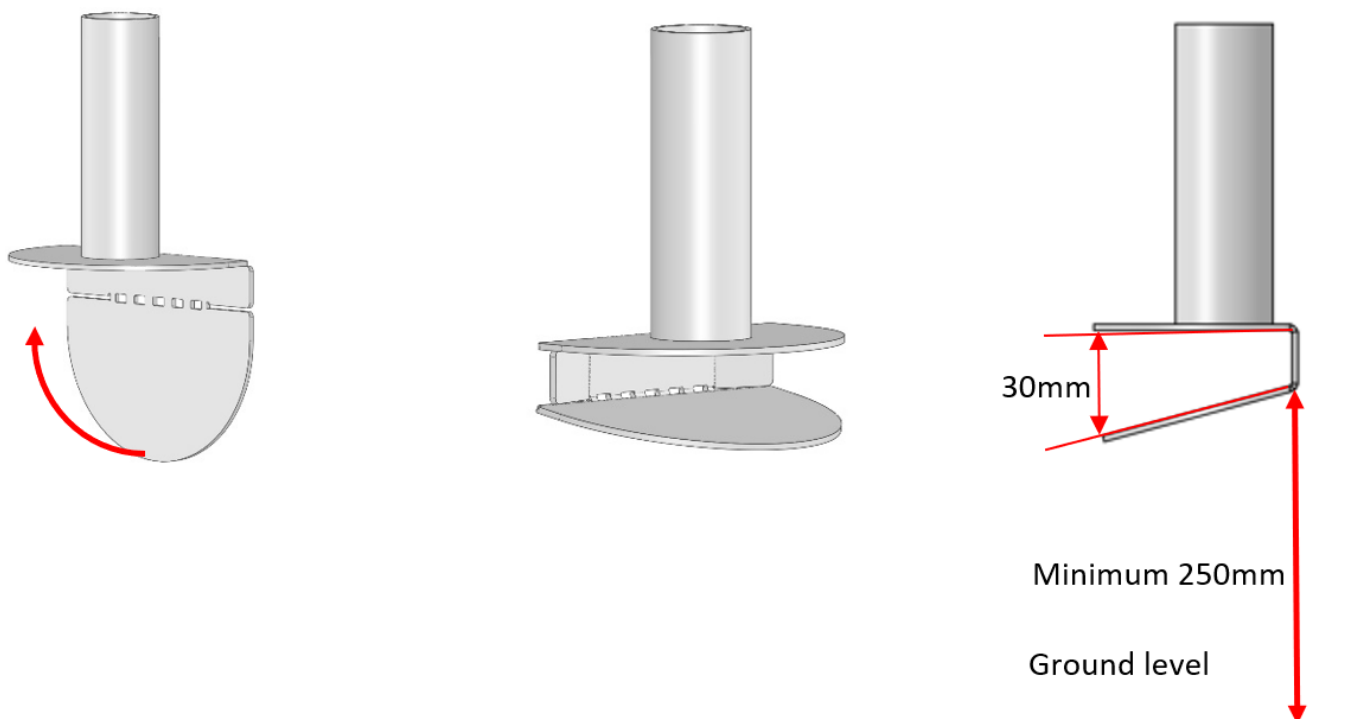

8.3 Spreader Plate Set Up—continued

There are two adjustable tabs on the back plate of each outlet. These tabs are used to create an even arc shaped spread pattern and when required, to adjust overlap between outlets.

When the back plate is left straight, some products can produce a spread pattern similar to the diagram below.

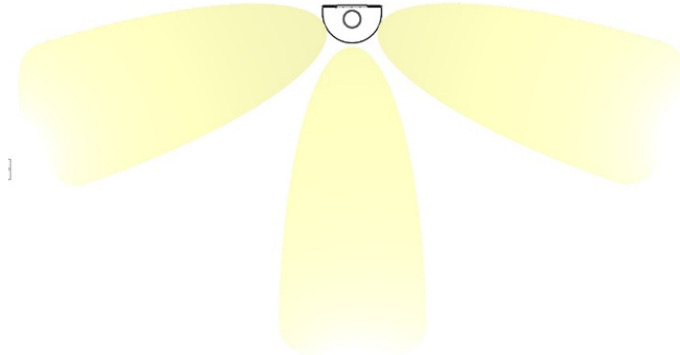

By bending the back plate tabs in slightly (see diagram below).

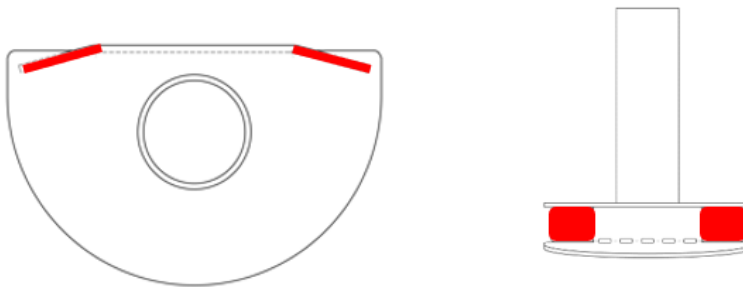

The coverage of product over the ground can be made much more uniform.



These recommended settings are an initial guide, set up vary between different products and machines fitments and required further adjustment.

8.4 C Section Rail

The spreader plates themselves are mounted to the "C" section rails, these can be ordered in 2m lengths as an option. Part no. **47TJT5008**. These can be cut down to suit the implement width. The "C" section rails can be attached to the implement using the supplied straight brackets, two per rail, which can be welded or bolted into position.

The spreader plates slide along the rails to give the planned spacing and lock into position using the integral bolts. It is generally better to position the spreader plates facing to the rear of the implement as this can prevent wet mud or tilth being thrown up into the mouth of the spreader causing blockages, especially if positioned close behind the tractor wheels, roller or discs.

8.5 Feed Hose

The feed hose comes in coils 30m long, to be ordered as an option with a new machine. Extra rolls can be ordered as a spare part, **part no TJ222-30M**. This requires cutting into lengths according to the positioning of the hopper and spreader. Ensure all hose runs are as short as possible whilst giving a smooth downhill route to the spreader plates. Avoid kinks, severe bends or uphill runs. Plan and measure the individual hose runs before cutting, fit the hose clips to the "Y" connector tails.



9.0 Machine Components

9.1 Feed Motor

The feed motor can be turned ON or OFF, either manually via the head unit, or automatically by the remote mounted spring finger switch, which can be fitted to the linkage or the implement. The feed motor must be switched ON via the head unit for the spring finger switch to work automatically.

9.2 Hopper Agitator

The internal agitator is powered independently by a separate motor. Its purpose is to prevent seed becoming compacted in the hopper and bridging (not flowing). It is recommended for all grass and grass seed mixes, or other seed that may bridge in the hopper, but it is not required for free flowing seeds such as OSR, clover, stubble turnips or similar, or granular products.

NOTE: If using the agitator in the field, also use it when calibrating.

9.3 12v Fan Unit

The double 12v fan unit is housed under the hinged meshed cover designed for easy access, and air is drawn through the mesh intakes on the rear, front, and sides of the cover, and underside the mounting base plate. This hinged cover can be lifted for cleaning purposes.

The Fan ON OFF switch is mounted on the side of the machine.

NOTE: Turn the fan **OFF** when calibrating, and **ON** once calibrated and ready for work.

9.4 Main Power Cable

The heavy duty power cable should connect directly to the vehicle battery posts to ensure adequate 12v supply to the fans. The in-line MAXI FUSE is 40 amp. This cable should reach to the back of the tractor in turn this is connected to the 5m heavy duty power extension cable which then connects to the power input flylead on the machine.

9.5 Instrument Lead

The 6m instrument lead connects to the junction box of the Turbo Jet, and runs to the control panel in the tractor cab.

NOTE: Extension power and instrument cables available if required.

Please contact your local Stocks Ag dealer for more information.

9.6 Spring Finger Switch

The switch should be mounted to a suitable place on the implement or linkage of the tractor, thus deflecting the spring, and automatically switching the feed motor off or on accordingly as the circuit is made or broken.

Position the finger switch so that the tip of the spring comes into contact with the moving part of the implement or linkage when lifted out of work, and remains deflected until the implement is lowered back into work. **NOTE.** Ensure that there is sufficient and positive deflection on the spring to prevent accidental switching ON or OFF if the implement moves slightly up or down in work.

The standard wiring as supplied for this switch is when the spring is at rest, the feed motor will run normally. If required, the switch can work in the opposite mode by changing the position of the 2 wires inside the switch so that the switch is out of work when the spring is at rest. To change over remove the PVC cover plate held in position with the retaining screw to access the wiring terminals. Remove the 2 wires from terminals 13 and 14 and re-connect to terminals 21 and 22 (nearest the gland nut) then re-fit the PVC cover plate.

NOTE: The area meter also stops when the feed motor stops

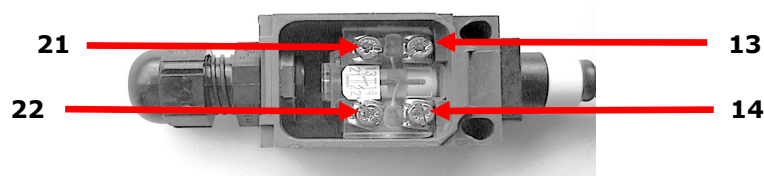

9.7 Junction Box

Positioned on the Turbo Jet under a cover above the fan, and houses 1 toggle switch to turn the fan ON or OFF, and the feed mechanism Prime Button. The switch is accessible to the side of the cover. Pushing the spring loaded Prime button will start the feed motor running at a pre-set speed during the calibration.

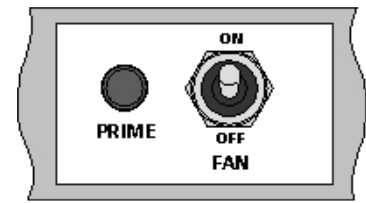

9.8 i-CON Instrument

A touch screen instrument which controls the sophisticated, CAN-based control system that provides complete control and monitoring of the applicator unit. Its primary function is to automatically maintain a pre-set target application rate as the forward speed varies, with on-the-move spot adjustment of the rate as required.



9.9 Hopper Level Sensor

A hopper level sensor is fitted as standard on i-CON machines which indicates low hopper contents.

9.10 Feed Rollers

Two types of feed roller kits are supplied with the machine as standard. The i-CON machine are fitted with the one Yellow 5mm wide small feed roller per outlet from factory with the other components making up the small feed roller kit packed in the hopper along with the larger 8 section grass seed roller kit.

Small Feed Rollers Fitted when applying small seeds such as Oil Seed Rape, Mustard, turnips, etc. and slug pellets. Typically 1 Yellow feed roller would be required per outlet when applying small seed and 1 or 2 White feed rollers when applying slug pellets depending upon the seed or product rate of application working width and forward speed. Up to 3 feed rollers per outlet can be fitted if required for other applications. Blanking spacers are also supplied in the kit to allow up to 3 outlets to be blanked off if required.

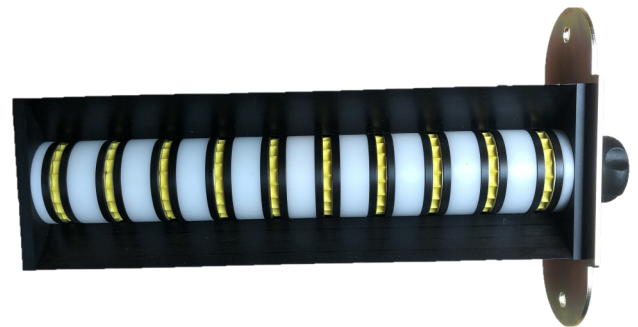

Outlet Feed Block with one Small Feed Roller fitted per outlet.

Grass Seed Rollers Deep 8 section feed rollers for higher application rates. Typically 8 feed roller would be fitted for high rate grass seed application. For lower rates or for narrow working widths 4 feed rollers can be fitted with one feed roller supplying product into two feed outlets, often required when applying cover crop mixtures.

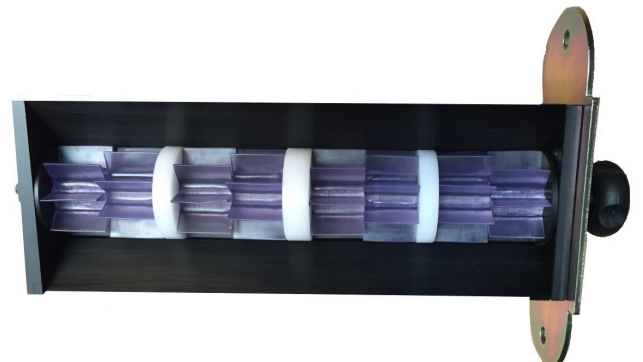

Outlet Feed Block with 8 Grass Seed Rollers fitted.

10.0 Inspection

10.1 12v Fan Inspection

⚠ WARNING! Always isolate the power before inspecting or servicing the machine.

To inspect the fan unit undo the two over-centre catches and hinge up the guard as shown below. Use an air line and brush to clean the fan blades regularly to maintain performance and prevent eccentric running. Always check the fan air intakes are clean and free from debris.

NOTE: The 12v fan has a self detection feature which shuts the fan off if it is out of balance.

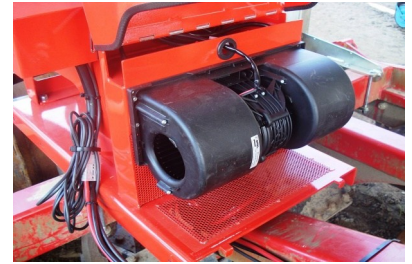

10.2 Feed Block Assembly Inspection

⚠ WARNING! Always observe all application standards and guidelines provided by the product manufacturer as some seed dressings and granular products may be toxic!

NOTE if unsure contact your seed or product supplier for more information.

1. Empty the hopper completely to prevent spillage, release the two over-centre catches and drop the hinged panel under the feed rolls and position the plastic collection tray directly underneath to catch any remaining seed or product.
 2. Undo and remove the 2 black plastic knobs holding the mechanism in place and slide out the feed block assembly.
- Be aware that the feed block assembly may retain some seed product.**
3. Use an air line and brush to clean the feed block and internal components, checking for any wear or damage replacing any worn or damaged parts as necessary. When doing this wear appropriate PPE.
 4. Before re-fitting the feed block ensure that the feed shaft can easily be turned by hand using the Black PVC knob fitted to the end of the shaft. If difficult to turn remove the end cap at the opposite end of the feed block assembly and remove all spacers and feed rollers by sliding each one off the shaft.
 5. Check the drive shaft engages correctly when sliding the feed block back into the machine by slowly rotating the central black plastic knob before re-fitting the outer black plastic retaining knobs.

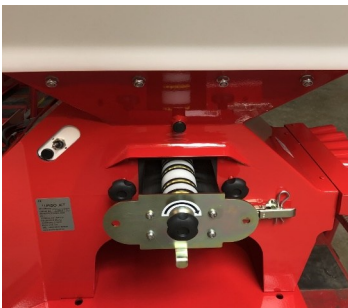

10.3 Agitator Shaft Inspection

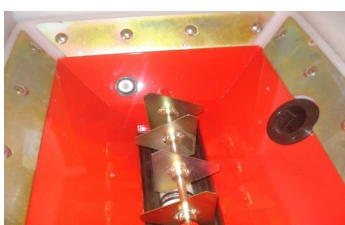

Check the internal agitator shaft to ensure it is clear of any debris and free to rotate.



11.0 Hopper Emptying Procedure



The hopper drain cap can be removed to help empty the hopper. Any remaining product is best removed by using an industrial vacuum before the feed block is removed from the machine. Once the feed block has been removed from the machine dispose of any remaining product held in the feed block. Release the bottom calibration door and check the air chambers for any sign of debris or build up of product and clear as necessary.

12.0 Clearing A Feed Hose Blockage

In the unlikely event of a blockage, remove the hose and clear any obstruction from within the hose or manifold on the machine. Remove the feed block and check the air chamber below the feed block opening and clear any debris. Re-position the feed hoses if this has been the cause of the problem.

13.0 Checking The Feed Motor

⚠ WARNING! This procedure must be carried out by a competent person who is aware of any risks involved.



Firstly empty the hopper then remove the feed block assembly.

Remove the motor guard by releasing the fixing screws.

Check to see if the feed motor shaft rotates when pressing the prime button. If the shaft is not rotating this may indicate the motor is faulty or has been damaged and needs to be replaced.

For any spare parts or if no faults are found and the alarm persists, contact your local Stocks Ag dealer.

14.0 i-CON Control System

14.1 i-CON Overview

All control system components integral to the Seed Applicator Unit are factory fitted in.

The Instrument has a 4.3" Colour Touch Screen which has 4 basic menu keys.

Separate heavy-duty power cable and head unit leads interconnect the tractor and the Seed Applicator Unit.

The following components need to be installed during fitment (packed in hopper from factory).

- i-CON Instrument: TJ117C
- Instrument cables: TJ118C and TJ242A
- Power supply cables: TJ238 and TJ247
- GPS Receiver: TJ255B
- Cut out Switch: TJ252

14.2 Wiring Diagram

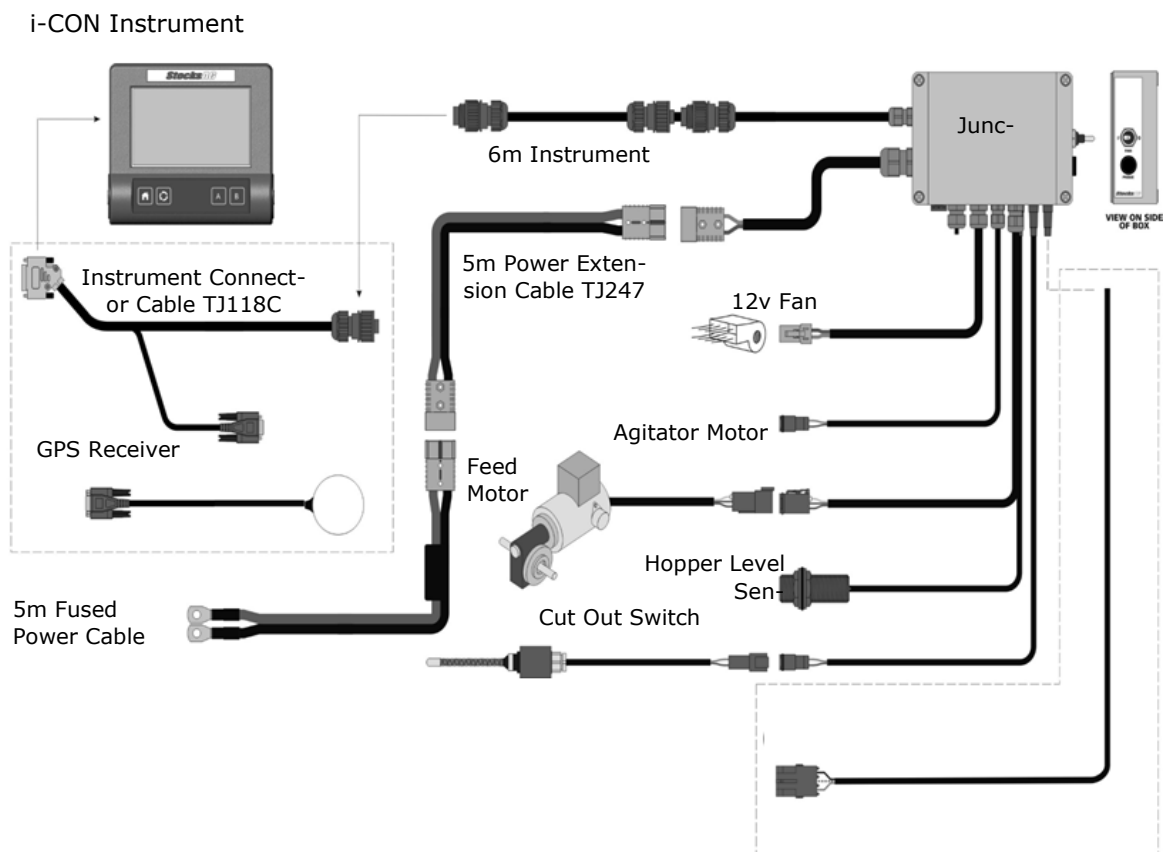

14.3 Electrical Connections

Ensure the power supply cable is connected directly to the vehicle battery to ensure maximum power.

Connect the positive wire (fused) to the positive (+) terminal and negative earth connection to the negative (-) terminal.

Failure to connect to the vehicle battery may result in control function problems and possible damage to the vehicle battery and charging system must be in good condition to achieve the best results. All cables and controls are fitted with matching plugs and sockets. Extension cables available.

Any modification to the wiring, fuse holder or controls will invalidate any warranty claim and may affect the performance.

Always replace any blown fuse with the same rated fuse as the original one fitted.

14.3 i-CON Instrument Functions

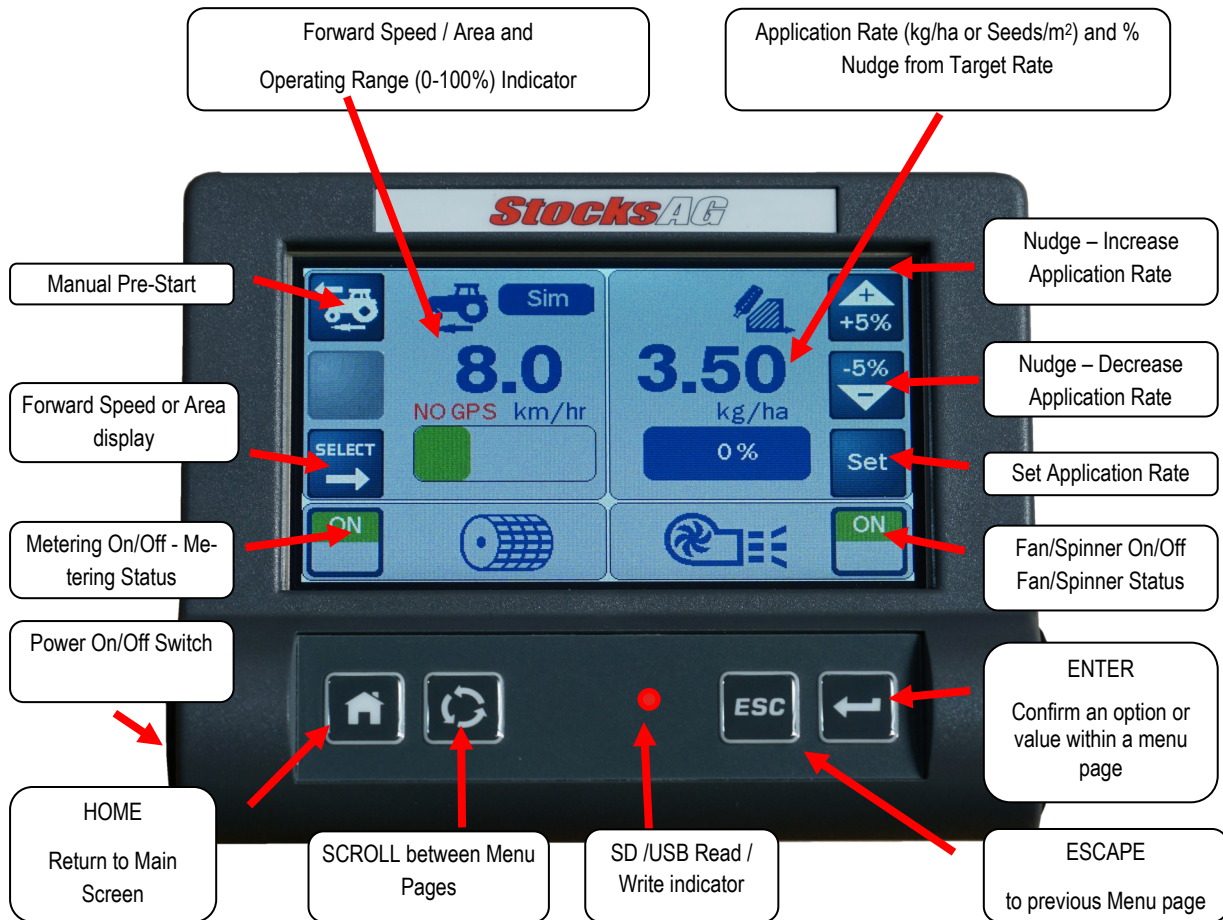

- Seed Application Rate (kg/ha or Seeds/m²).
- Forward Speed (km/hr).
- Minimum/Maximum Forward Speed indicator with alarms, (beyond which the programmed seed rate cannot be maintained).
- Metering Unit Status (On/Off) and Alarm.
- Fan (or Spinner - depending on installation) Status (On/Off) and Alarm.
- Hopper contents (kg) and Low Level Alarm.
- Part and Full (Job) Totals for Area (ha), Product dispensed (kg) and hours worked.
- Grand Total for Area (ha), Product (kg) and hours worked.

Other features include:

- Simple and intuitive touchscreen Alarm codes and diagnostic displays in the event of system malfunction.
- Menus for Forward Speed / Product calibration and adjustment.
- Pre-start' - ensures seed delivery begins immediately the drill enters work (user-programmable).
- Rate 'Nudge' - on-the-move rate adjustment in pre-set increments (user-programmable).

NOTE: A comprehensive control system user guide also supplied (packed with the i-CON instrument).

14.4 Precision Farming Software - Optional

The instrument can be unlocked to activate the precision farming program as a cost option.

This is something that can be requested when the machine is purchased or can be added at a later date.

15.0 i-CON Calibration

You will need the supplied plastic calibration tray, and an accurate set of scales which weighs in grams.

15.1 At The Junction Box

1. Switch the fan OFF at the junction box.
2. Release the two over-centre catches and drop the hinged panel under the cassette manifold.
3. Position the collection tray directly underneath to catch the seed.
4. Place a few kilograms of seed in the hopper.

15.2 At The i-CON Instrument

1. Switch the spinning disc / fan off at the instrument
2. Switch the head unit ON via the left hand side push button – wait until the start-up routine has finished and displays the main “home screen”
3. Scroll through  to the Setup Menu and select the Applicator Icon.
4. Adjust the implement width accordingly - refer to the RDS manual, Set Implement Width.

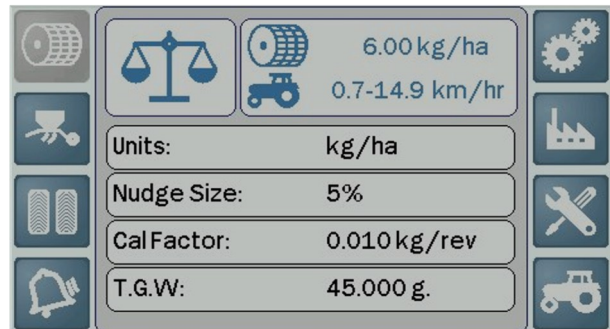

5. Ensure the correct application rate is entered – select and adjust accordingly, refer to the RDS manual, Setting the Application Rate.

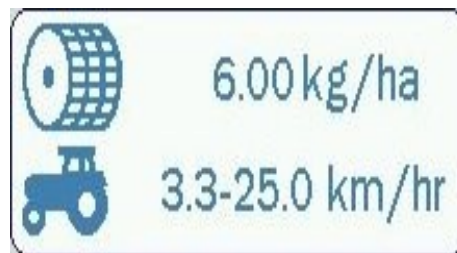



6. Ensure the feed roller setup is appropriate for the intended product or seed type, application rate and forward speed range for application.

7. The instrument calculates the calibration factor from the working width, target application rate, and the metered weight delivered whilst calibrating. If however as a result of the calibration routine, you find that you cannot achieve your desired field speed, displayed in the top right corner of the screen, then re-configure the feed roll assembly and repeat the calibration procedure.

8. Prime the feed rolls with product by pressing and holding briefly the prime button on the junction box - this will ensure a higher initial calibration accuracy, empty the contents of the tray back into the hopper.

9. For an **Auto Calibration** from the Product Setup page, touch 

10. Touch  and enter the quantity that you wish to dispense for calibration purposes. You can enter the quantity in grams if preferred. The CAL factor will however, still be calculated in kg/rev.

11. Touch on the screen page 

12. After the  key the motor runs at the calibration speed (calculated from the Simulated Forward Speed, Width, Application Rate and current calibration factor).

13. The dispensed weight (based on the current calibration factor) is displayed.

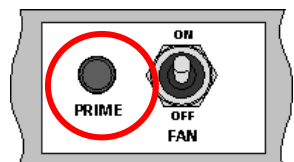

14. Weigh the product dispensed and then enter the measured weight, and press 



15. A new calibration factor is then re-calculated and displayed.

16. Your in-field min and max speeds will be displayed as per the image to the right hand side. If you find that you can not achieve your desired field speed, then re-configure the feed roll assembly and repeat the calibration procedure **NOTE:** Recommended min speed 0.8kph - 1.2kph (if not see feed roller configuration).



17. Touch  to save the new factor, it is advised to repeat the calibration two more times to ensure accuracy.

15.3 Manual Calibration

1. For a **Manual Calibration** press and hold the Prime button on the junction box, the larger the quantity dispersed the higher the accuracy the final calibration factor will be, release the prime button once sufficient product has been dispensed.
2. The estimated dispensed weight (based on the current calibration factor) is displayed.
3. Weigh the product dispensed (in grams) and then enter the measured weight, and press .
4. A new calibration factor is then re-calculated and displayed.
5. Your in field min and max speeds will be displayed. If you find that you cannot achieve your desired field speed, then re-configure the feed roll assembly and repeat the calibration procedure.
6. Touch  to save the new factor, it is advised to repeat calibration two or three more times to ensure accuracy.

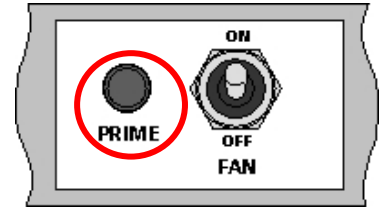

15.4 GPS Speed

The i-CON control system is automatically configured to run with GPS receiver supplied and is a simple plug and play device. This system only works outside and if you are not receiving a GPS signal an alarm will be displayed on the main screen indicating NO GPS.

15.5 Common Calibration Mistakes

- Ensure you enter the width and required rate correctly – that the decimal point is in the correct position. If the rate is 2.5 kg/ha, enter 2.5. (not 25 - which is 25kg/ha).
- Remember to deduct the weight of the collection bag or bucket – weigh only the contents.
- Ensure you work in grams – not kilograms.
- Ensure you are working in the mode required – either Kilograms per Hectare or Seeds per Square Metre. The standard default mode for the i-CON is in Kgs/Ha and you will have to reconfigure the display if you want to display Seeds per Square Metre. You do not need to enter or change the TGW if working in Kgs/Ha – only if working in Seeds per Square Metre - Refer to the RDS manual.
- Ensure you check the minimum and maximum speeds displayed, and that they are sensible for your field operation. This is the speed range that the i-CON can maintain the required application rate, and depends on the width of your machine, the application rate required, and the type and configuration of feed rolls fitted.
- Ensure that the speed range will work for you in the field – ensure that your target forward speed will not be close to either the minimum or the maximum of the range, and that you have some reserve of speed range above and below the in-field forward speed. Ideally your forward speed will be in close to the middle of the range.
- If the minimum is too high, for example 4kph then the feed motor will be running too slowly if your forward speed drops towards the minimum as you set in and lift out of work, and this could result in missed patches (although the alarm will trigger when either the minimum or maximum speed is reached).
- If the indicated speed range does not work for your operation, you must change the feed roll configuration or the type of feed roll to apply more or less seed, per revolution of the feed mechanism, as required. Once completed, recalibrate and note the new speed range.

15.6 Ready For Work

Close the hinged panel and secure with the over centre catches.

Ensure the fan is running – switch junction box fan switch to ON.

Ensure the feed motor is running and agitator motor is switched on if required.

Check all outlet pipes are seeding correctly before commencing work.

16.0 Feed Block Assembly Guide

⚠ WARNING! The moving parts of this machine are powerful and can cause injury. Be especially careful whilst performing calibration tests.

⚠ WARNING! Always observe all application standards and guidelines provided by the product manufacturer as some seed dressings and granular products may be toxic.

NOTE: If unsure contact your seed or product supplier for more information.

16.1 Feed Roller Configuration

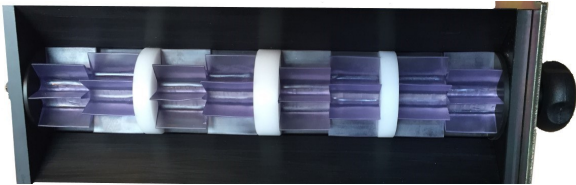

When supplied from the factory unless specified the machine will be fitted with 8 section feed rollers for grass seed, grass mixes and some cover crops applications. Normally one feed roller per outlet required as fitted for grass seed application and typically applied at 35kg/ha over a 6m working width.

For lower outputs requirements for example when applying over a 3m working width or to apply some cover crops then the number of feed rollers can be reduced - see Feed Roller section showing how the feed rollers and spacers need to be assembled.

In addition the machine is supplied with a second feed roller kit for lower rate applications such as small seed and slug pellet applications as shown below.

Yellow feed rollers are typically used for small seed application such as OSR with 1 feed roller fitted over each outlet as shown below. If higher rates are required the **white** feed rollers can be used.

NOTE: Yellow feed rollers apply approx. 40% less than the white rollers - Product dependant.

If you cannot achieve the required rate using just a single yellow or white roll, then use multiple rolls together per outlet for example 2 or 3, you can also mix the yellow and white provided each outlet has the same configuration of feed rolls. Other components from this kit which include 16 white feed rollers and 3 black 5mm blanking spacers will be found in a bag packed inside the hopper.

⚠ WARNING! It is the responsibility of the operator to ensure the feed block assembly is suitable for the product being applied.

NOTE: Before applying very fine seeds or product please contact your local dealer or Stocks Ag directly to ensure the machine is suitable. Failure to do so could invalidate your warranty.

The feed rollers are easily exchanged by removing the feed mechanism as follows:

1. Ensure the hopper is completely empty
2. Undo and remove the 2 black plastic knobs holding the mechanism in place and slide out the feed block.
3. Undo and remove the 4 socket head screws on the end of the housing and remove the end plate. Slide the feed rollers and spacers off the shaft and replace with the alternative rollers required.

The black blanking spacers (3 supplied) are the same width as the small seed rolls and are used in combination with the feed rolls to allow 1, 2 or 3 feed rolls per outlet to be used or to replace the feed rolls and blank off an outlet completely. For example if reducing the number of outlets from 8 to 7, to correspond with subsoiler legs or tines, remove all the feed rollers from that outlet and replace with a 5mm blanking spacer.

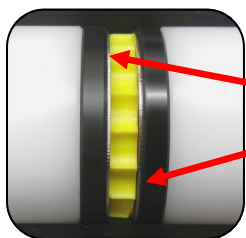

NOTE one stainless disc needs to be fitted to each side of the 5mm small seed rolls. They are used to reduce the friction element between the small seed rolls and the plastic spacers that are to each side of them.

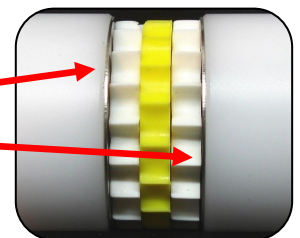

Remember to blank off the relevant air pipes using the push in PVC plugs supplied.

NOTE: When re-fitting the end plate to the feed block after changing the feed roller configuration, the end plate should be able to fit flush with the feed block by hand, without having to pull it home with the socket head screws. The assembled rolls and spacers should not be under compression. To check the correct feed roller and spacer configuration. Once re-assembled, slide the feed block assembly back into the machine ensuring the drive shaft engages correctly by slowly rotating the feed shaft. Once engaged secure the two black plastic retaining knobs.

16.2 Feed Block Assemblies - Optional

For some applications, such as applying very small seed or granular product, a low rate feed block assembly is recommended. This block has been developed to eliminate finer products from leaking around the feed rollers and into the airstream. These feed blocks can be used with the standard feed rollers supplied with the machine when applying very small seeds at low rates.

Part Number: **TJ196B** (8 outlet machine)

Part Number: **TJ196F** (10 outlet machine)

For fine granules at higher application rates such as *Avadex® Excel 15G the following feed block assemblies kits will be required.

Part Number: **TJ8-20 Section** (8 outlet machine)

Part Number: **TJ10-20 Section** (10 outlet machine)

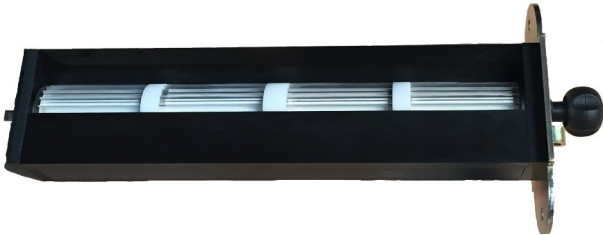

Photo showing a TJ8-20 Section Feed Block Assembly

NOTE: When assembling the feed rollers, ensure the outer two rollers are positioned so that the blank end faces each of the end plates.

16.3 Feed Block Assembly - Optional

For Fertiliser Application

For applying abrasive granular products such as starter fertiliser or low rates of prilled fertiliser the Low Rate feed block fitted with stainless components must be used.

Part Number **TJ8SS** (8 Outlet Machine)

Part Number **TJ10SS** (10 Outlet Machine)

⚠ WARNING! It is the responsibility of the operator to ensure the feed block assembly is suitable for the product being applied.

NOTE: before applying very fine seeds or product please contact your local dealer or Stocks Ag direct to ensure the machine is suitable. Failure to do so could invalidate your warranty.

17.0 Hopper Baffle Plate

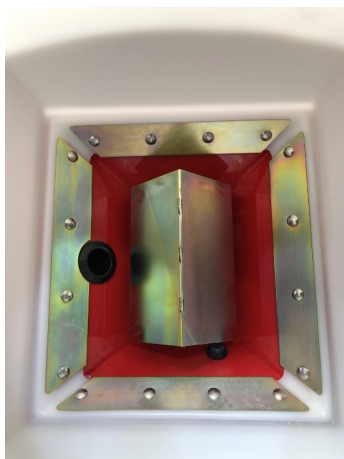

Turbo Jet 8 Hopper Baffle Plate Part number: **TJ471**

Turbo Jet 10 hoper baffle plate Part number: **TJ472**

⚠ WARNING! A Hopper Baffle Plate must be fitted when applying fertiliser or any other dense product to reduce the pressure on the feed block assembly and so reduce strain on the feed motor. Failure to do so may damage the feed motor and invalidate the warranty.

NOTE: All 400L machines are supplied with a hopper baffle plate as standard.

All parts available through your local Stocks Ag dealer.

*Avadex ® is a Trademark used under licence by Gowan Crop Protection Ltd,.

18.0 Hydraulic Fan (Optional)- Specification

Hydraulic Fan Specification		
Model	FC4	
Max RPM	7000	rpm
Max Operational RPM	6000	rpm
Max Pressure	210	bar
Max Operational Pressure	172	bar
Displacement	4.1	cc
Flow	27.3	L/min
Power	9.54	NM
Weight	16	kg

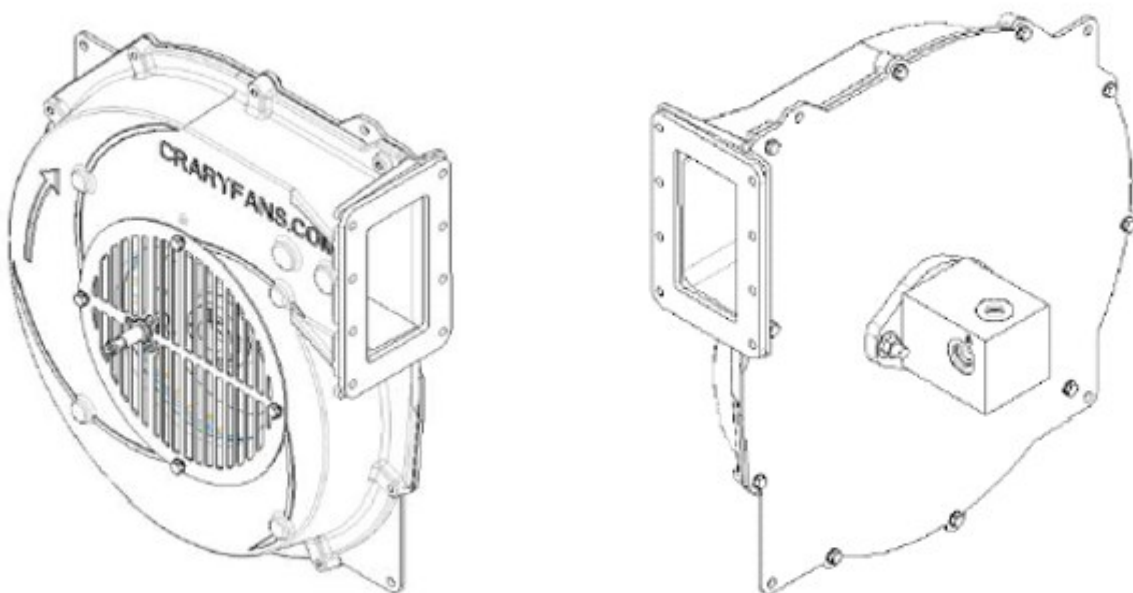

18.1 Hydraulic Fan - Safety

The hydraulic system on the machine operates under high pressure. (Maximum of 210 bar). Pressurised hydraulic oil is dangerous so connecting/disconnecting the fan must only be undertaken with the tractor engine turned off and the pressure in the hoses released. Before operating the machines hydraulics, always inspect the hoses and fittings to ensure there is no damage or loosened parts. If you find any damaged hoses, you must contact your dealer to have them replaced immediately.

Never try to block leaking hydraulic hose pipes with your hand or fingers! Hydraulic oil leaking out under high pressure may enter the skin and bloodstream and cause serious injuries. If injuries caused by hydraulic oil occur, immediately contact the medical services.

The tractor must be equipped with a free-return flow hydraulic connector (NO BACK PRESSURE). The oil flow necessary to drive the fan is taken from the tractor hydraulic remote valves, through a 3/4 inch delivery hose with BSP male fitting. The rotational speed of the hydraulic motor, and therefore the fan, is connected to the oil flow adjustable from the tractor's controls. The hydraulic motor safety valve makes it possible for the device to keep on turning by momentum, even after the system has been shut off. It is important to connect the return hose of the hydraulic motor to a free flow connection on the tractor; this free discharge cannot generate any back-pressure exceeding 2 bar.

Failing to follow these instructions will increase the risk of motor failure and increase the risk of premature failure.

18.2 Hydraulic Fan - Fitting Position

The hydraulic fan will draw in large quantities of air when running. The air inlet to the fan must be kept clear of obstructions. Where possible, mount in a location that will minimise the amount of dust being drawn in, as this will impede the performance of the applicator.

The hydraulic fan is supplied with a pair of 4 metre long hoses, for pressure and return to reach from the fan motor to the remote (spool) valves on the tractor. For trailed implements, please allow some extra slack in the hoses, which will be required when making sharp turns.

The hydraulic fan is supplied with a 2 metre hose that connects the fan outlet to the air inlet manifold of the applicator.

18.3 Hydraulic Fan - Speed Setting

The hydraulic fan generates a greater volume of air flow at higher speeds than the 12v electric fans, allowing higher volumes of material to be conveyed over wider working widths.

The fan is driven by a hydraulic motor, which is powered by the tractor hydraulic system.

The hydraulic motor has a overrun protection built in.

The rpm of the fan is measured by a NPN (Negative Positive Negative) sensor with a two pulse pick up point (2ppr).

The fan speed determines the volume and speed of air used to deliver product to the outlets. The correct speed required varies depending on product size, application rate and overall working widths. Fan speed is altered by adjusting the flow control on the hydraulics of the tractor.

If the tractor is not equipped with variable flow control on the hydraulic remote (spool) valves, there is a flow control valve available as an optional extra. This valve fits on the pressure hose at the tractor end. The speed is adjusted by restricting the oil flow to the fan.

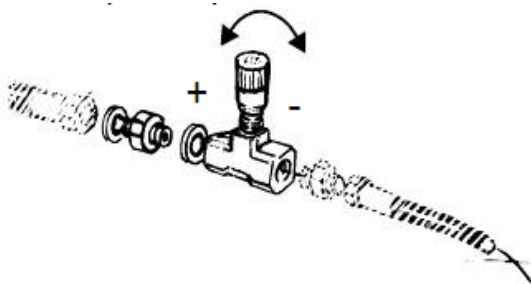

Optional flow control valve for adjusting fan speed

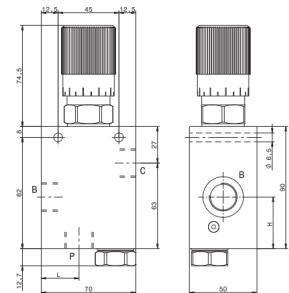

18.4 Hydraulic Fan Speed Guide

The fan speeds in the table below are just an rough guide. The correct speed required will alter greatly between varying setups depending on machine location, hose length and hose routing.

Fan Speed rpm	6m	8m	12m	15m
3500	Small seeds, OSR, Clover	Small seeds, OSR, Clover		
4000	Slug pellets, Avadex	Small seeds, OSR, Clover		
4800	Barley, Wheat, Fertiliser	Slug pellets, Avadex	Small seeds, OSR, Clover	Small seeds, OSR, Clover
5500	Larger Seeds, peas	Barley, Wheat, Fertiliser	Slug pellets, Avadex	Slug pellets, Avadex
6000	Larger Seeds, peas	Larger Seeds, peas	Barley, Wheat, Fertiliser	Barley, Wheat, Fertiliser

18.5 Hydraulic Fan - Speed Display

When the hydraulic fan option has been purchased, the i-CON control box will come pre-configured to display the fan speed on the screen in rpm.



18.6 Hydraulic Fan - Speed Sensor

The fan speed sensor requires mounting in the grill over the fan inlet, using the hole provided.

Each time one of the bolt heads mounted on the fan blade passes in front of the sensor, it generates a pulse and the LED on the back flashes red.

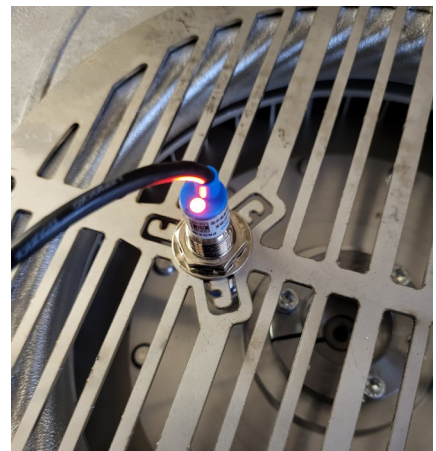

The picture opposite shows the two bolt heads that are used as the pick up points for the fan speed sensor.

The grill over the fan inlet has to be removed to fit the sensor. The grill is held in place with four M8 bolts.

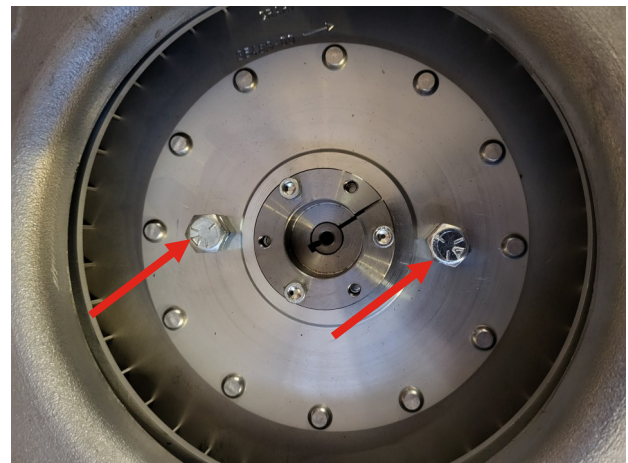

It is vital to install the fan speed sensor in the correct position. The sensor has an M12 fine thread with two nuts and lock washers to hold it in place. The blue tip to the sensor is roughly 30mm from the underside of the grill cover.

The critical measurement is the 1.5mm clearance between the sensor tip and the bolt heads. If the distance is too great, the LED will not flash. If it is too little, there is a risk of permanent damage to the sensor.

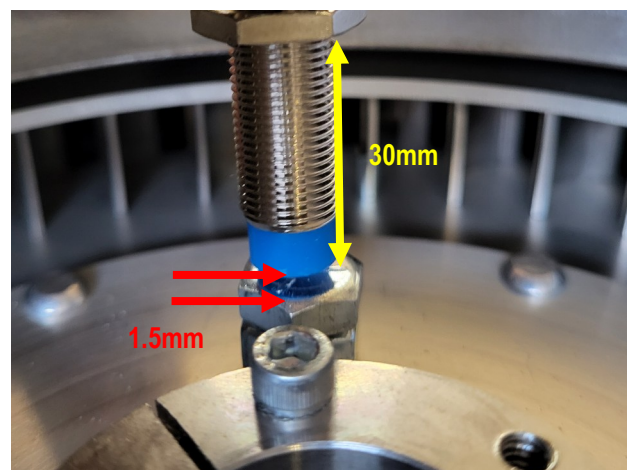

18.7 Hydraulic Fan - Mounting

To mount the hydraulic fan, the back plate is pre drilled with four M8 bolt holes.

It is recommended that all four bolt holes are used to mount the fan on a frame to support the fan securely.

The diagram below give the dimensions for the hole location and spacing.

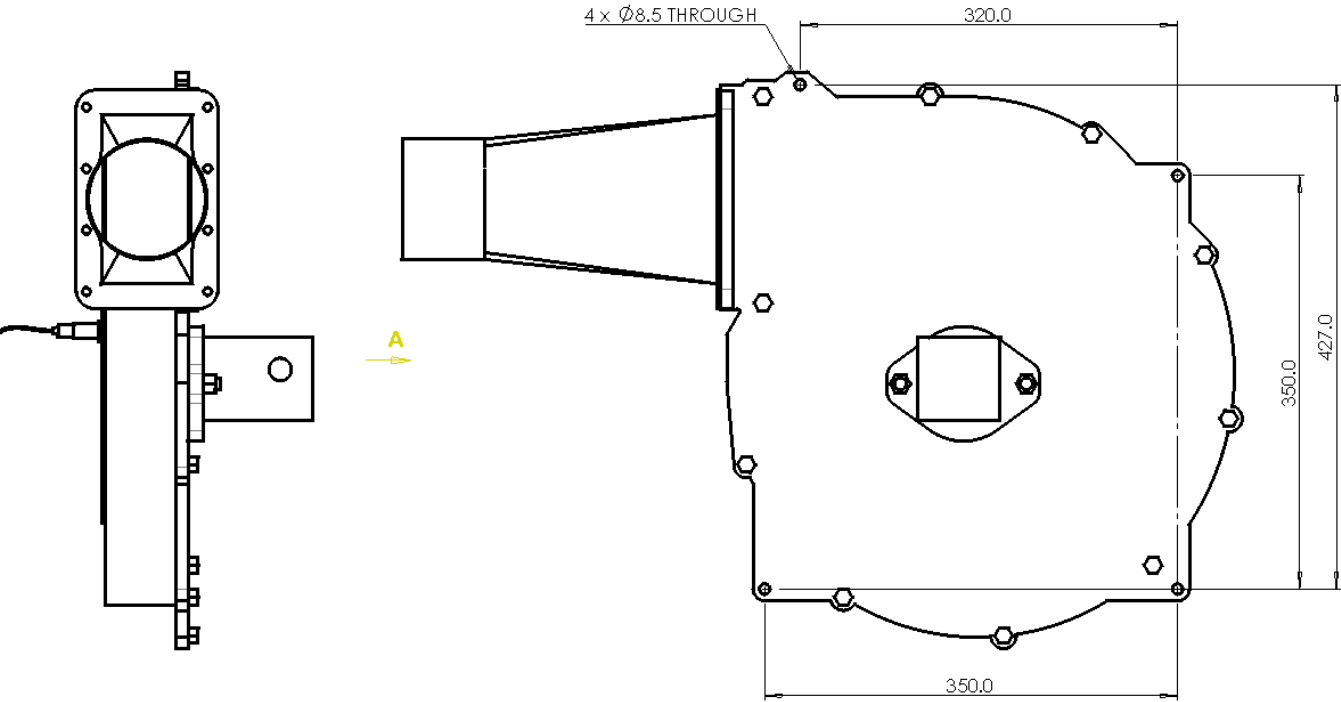

19.0 Turbo Jet Parts

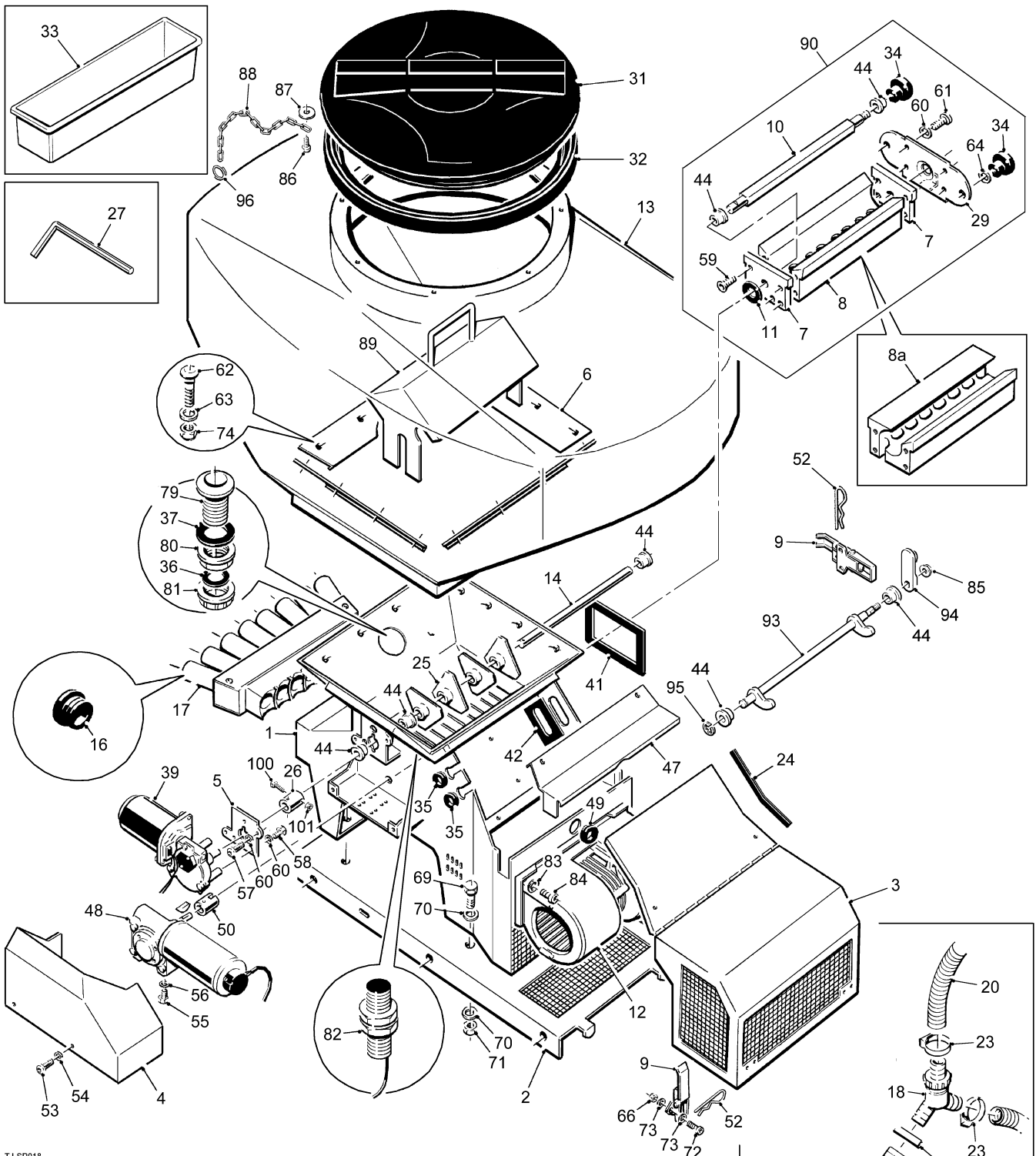

TJ-SP018

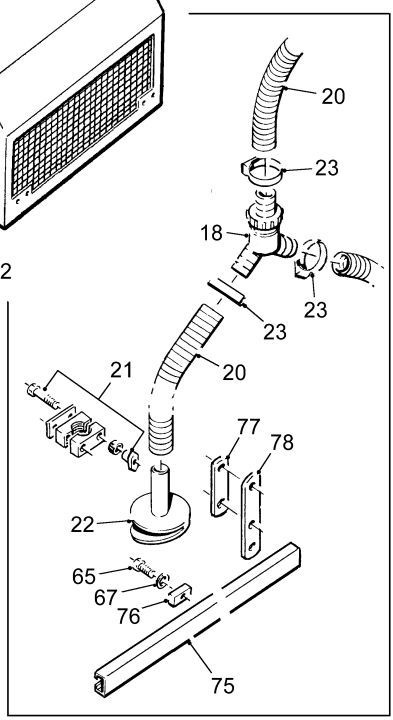
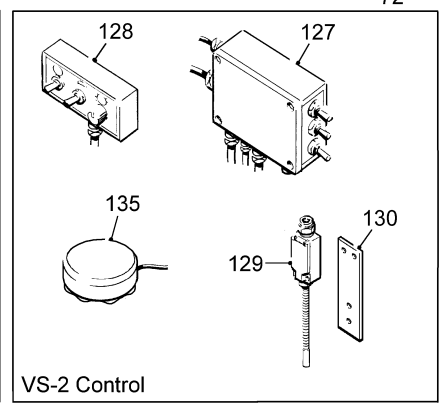
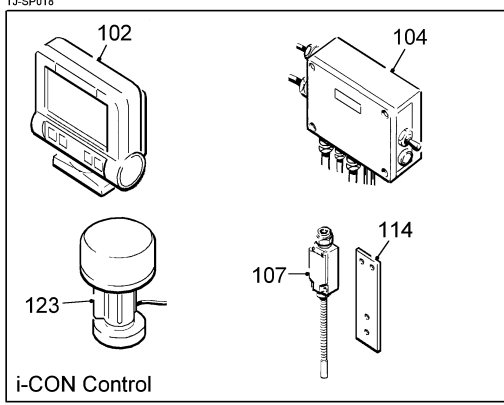

19.1 Turbo Jet Part Numbers

Item	Part No.	Description	Qty.	Remarks
1	TJ400A	Chassis (8 outlet)	1	
	TJ400B	Chassis (10 outlet)	1	
2	TJ422	Base Plate (8 & 10 outlet)	1	
3	TJ425A	Fan Guard (8 outlet)	1	
	TJ425B	Fan Guard (10 outlet)	1	
4	TJ418	Motor Guard (8 outlet)	1	
	TJ459	Motor Guard (10 outlet)	1	
5	TJ429	Agitator Motor Plate	1	
6	TJ465	Support Plate Kit	1	Set of 4 plates
7	TJ101A	Feed Block End Cap	2	Counter Bored
8	TJ102	Feed Block (8 outlet)	1	
	TJ098C	Feed Block (10 outlet)	1	
8a	TJ102A	Low Rate Feed Block (8 outlet)	0	Cost Option
	TJ098D	Low Rate Feed Block (10 outlet)	0	Cost Option
9	TJ103	Fastener Assembly	4	
10	TJ104D	Metering Shaft (8 outlet)	1	
	TJ099C	Metering Shaft (10 outlet)	1	
11	TJ033	Gasket	1	
12	TJ124C	Double Fan Unit (8 & 10 outlet)	1	
13	TJ126A	Hopper (240L)	1	
	TJ125A	Hopper (400L)	1	
14	TJ138	Agitator Shaft (8 outlet)	1	
	TJ138A	Agitator Shaft (10 outlet)	1	
15				
16	TJ219	Blanking Plug (8 & 10 outlet)	3	
17	TJ218A	Feed Unit Manifold (8 outlet)	1	
	TJ217A	Feed Unit Manifold (10 outlet)	1	
18	TJ220- Assembly	"Y" Connector—Assembly	8 or 10	8 or 10 outlet
20	TJ222	Ø32mm Hose	30m	Not shown
21	TJ223	Clamp Assembly		
22	TJ224	Spreader Plate (Assembly)		8 or 10 outlet
23	TJ227	Ø40mm BZP Hose Clip		8 or 10 outlet
24	TJ038	Strip Seal	2.4m	
25	TJ021A	Agitator Paddle (8 outlet)	4	
	TJ021A	Agitator Paddle (10 outlet)	5	

19.2 Turbo Jet Part Numbers Cont

Item	Part No.	Description	Qty.	Remarks
26	TJ137	Coupler	1	
27	TJ131	4mm Allen Key	1	
29	TJ416	Cassette Mounting Plate	1	
31	TJ128	Hopper Lid	1	
32	TJ129	Neck Ring	1	
33	TJ130	PVC Calibration Tray	1	
34	FJ033A	M8 Fem Knob	3	
35	GRO03	Rubber Grommet	2	
36	TJ053	Rubber Washer	1	
37	TJ054	Rubber Washer	1	
39	GA046B	Agitator Motor	1	
41	TJ040	Feed Block Gasket	1	
42	TJ041	Junction Box Gasket	1	
44	GA103	PVC Flanged Bush	6	
45	TJ055-1	PVC Plug	1	
47	TJ430	Hinge Guard (8 outlet)	1	
	TJ431	Hinge Guard (10 outlet)	1	
48	TJ044B	Feed Motor	1	
49	TJ039	Rubber Grommet	1	
50	TJ043A	Coupler	1	
51	M10-004	M10x25 Bolt	3	
52	FJ419A	R' Clip	4	
53	M6-003	M6 Setscrew	2	
54	M6-016	M6 Flat Washer	2	
55	M5-011	M5 Setscrew	4	
56	M5-014	M5 Flat Washer	4	
57	M6-004	M6x16 Bolt	2	
58	M6-004	M6x16 Bolt	3	
59	M6-007	M6x20 CSK Setscrew	4	
60	M6-016	M6 Flat Washer	6	
61	M6-008	M6x25 Button Head Setscrew	4	
62	M8-004	M8x20 Dome SQ Bolt	16	
63	M8-010	M8 Flat Washer	16	
64	M8-012	M8 Penny Washer	2	
65	M10-001	M10x16 Bolt	a/r	
66	M4-004	M4 Lock Nut	4	
67	M10-016	M10 Flat Washer	a/r	
68	M10-024	M10 Lock Nut	3	
69	M12-003	M12x35 Bolt	4	

19.3 Turbo Jet Part Numbers Cont

Item	Part No.	Description	Qty.	Remarks
70	M12-008	M12 Flat Washer	8	
71	M12-014	M12 Lock Nut	4	
72	M4-001	M4x6 Socket Head Setscrew	8	
73	M4-006	M4 Flat Washer	8	
74	M8-019	M8 Lock Nut	16	
75	TJ150	'C' Rail 2 metre length	4	
76	TJ151A	Channel Nut	a/r	
77	TJ152-1	Short Clamp Plate 2 Holes	a/r	
78	TJ153	Long Clamp Plate 3 Holes	a/r	
79	TJ050	Tank Outlet	1	
80	TJ051	Nut	1	
81	TJ052	Blanking Cap	1	
82	TJ251A	i-CON Hopper Level Sensor	1	
83	M4-006	M4 Flat Washer	8	
84	M4-003	M4 Setscrew	8	
85				
86	TJ1285	Self Tapping Screw	2	
87	M5-015	Washer		
88	MM019	Loop Link Chain	1	
89	TJ471	Tank Baffle (8 outlet)	1	400L models only
	TJ472	Tank Baffle (10 outlet)	1	400L models only
90	TJ196A	8 Outlet Feed Block Assembly	1	
	TJ196E	10 Outlet Feed Block Assembly	1	
	TJ196B	8 Outlet Low Rate Feed Block Assembly	1	Cost Option
	TJ196F	10 Outlet Low Rate Feed Block Assembly	1	Cost Option
93	TJ435A	Door Release Shaft TJ8	1	
	TJ440A	Door Release Shaft TJ10		
94	TJ437A	Door Release Catch Plate	1	
95	TJ433	E-clip	1	
100	M3-003	M3 Bolt	1	
101	M3-008	M3 Lock Nut	1	
102	TJ117C	i-CON Instrument Control Panel	1	
103	TJ118C	i-CON Instrument Connector Cable	1	Not shown
104	TJ119D	i-CON Junction Box	1	
107	TJ252	Finger Cut Out Switch	1	
108	TJ254	6m Switch Cable	1	Not shown
109	TJ235	Instrument Mounting Bracket	1	Not shown

19.4 Turbo Jet Part Numbers Cont

Item	Part No.	Description	Qty.	Remarks
111	TJ238	5m Fused (40A) Power Cable	1	
112	TJ242A	6m i-CON Instrument Ext. Cable	1	
113	TJ247	5m Power Extension Cable	1	
114	TJ253	Finger Switch Mounting Plate	1	
115				
116				

Optional extension cables available				
117	TJ240A	i-CON Instrument Ext Cable 4m	-	Cost Option
118	TJ244A	i-CON Instrument Ext Cable 10m	-	Cost Option
119	TJ247	i-CON Power Ext Cable 5m	-	Cost Option
120	TJ250	i-CON Power Ext Cable 10m	-	Cost Option
121				
122				
123	TJ255B	GPS Receiver	1	

20.0 Feed Roller Kits Parts

Turbo Jet 8 Outlet

TJ195A
Small Seed Feed Roller Kit
(5mm)

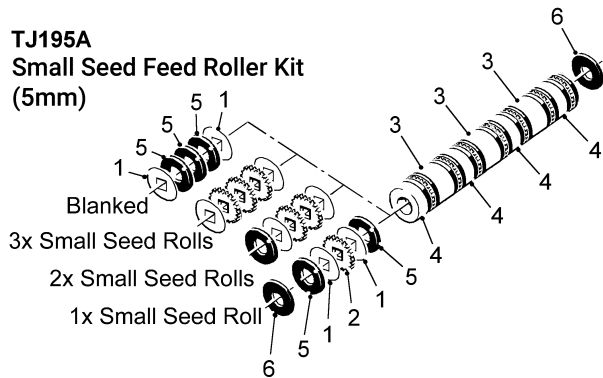

TJ195B
Granular Feed Roller Kit
(20 Section)

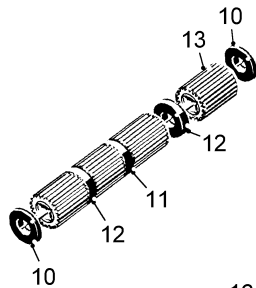

TJ193A
Large Seed Feed Roller Kit
(Grass)

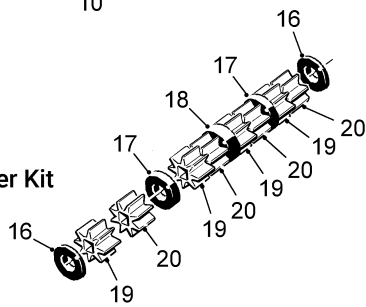

TJ192A
1/2 Large Seed Feed Roller Kit
(Grass)

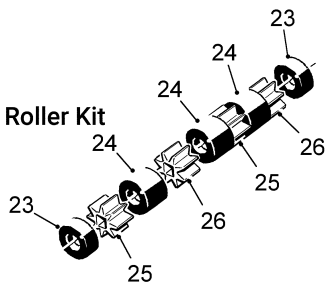

Turbo Jet 10 Outlet

TJ197C
Small Seed Feed Roller Kit
(5mm)

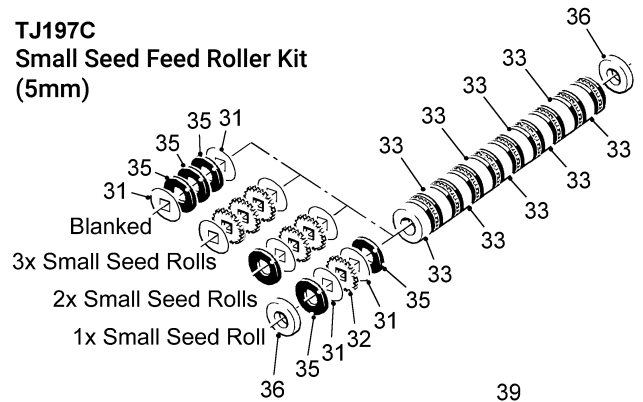

TJ197B
Granular Feed Roller Kit
(20 Section)

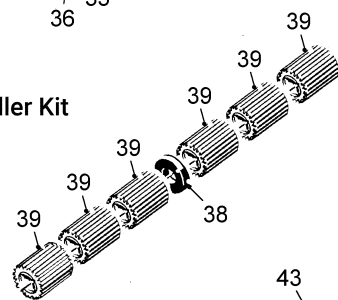

TJ197D
Large Seed Feed Roller Kit
(Grass)

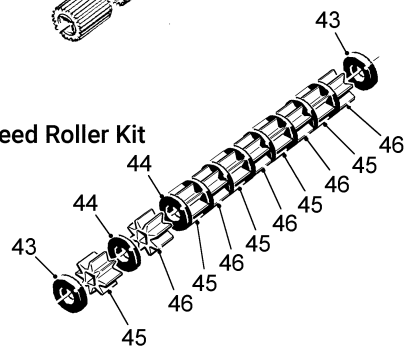

TJ197E
1/2 Large Seed Feed Roller Kit
(Grass)

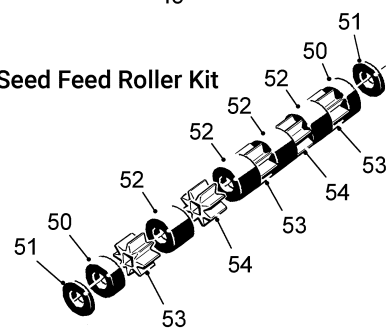

**Large Seed Feed Rollers
(Grass)**

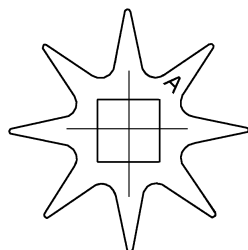

Part No. GA110B-A

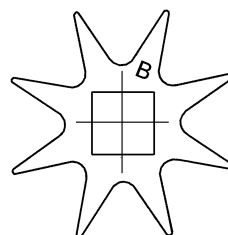

Part No. GA110B-B

TJ-SP015

20.1 Feed Roller Kit Part Numbers

Item	Part No.	Description	Qty.	Remarks
	TJ195A	8 Outlet 5mm Small Seed Feed Roller Kit consisting of the following:		
1	TJ199	Stainless Steel Shim	16	
2	TJ200	5mm Small Seed Roller (White)	16	
	TJ201	5mm Small Seed Roller (Yellow)	8	
3	TJ203	24.6mm Spacer	3	
4	TJ204	13.5mm Spacer	4	
5	TJ205	5mm Spacer	19	Includes 3 spare
6	TJ207A	3mm Spacer	2	
7	TJ219-1	PVC Manifold Blanking Plug	3	Not shown
	TJ195B	8 Outlet 20 Section Seed Feed Roller Kit consisting of the following:		
10	TJ207A	3mm Spacer	2	
11	TJ208	10mm Spacer	1	
12	TJ212	12.25mm Spacer	2	
13	GA110	20 Section Feed Rollers	4	
	TJ193A	8 Outlet Grass Seed Feed Roller Kit consisting of the following:		
16	TJ207A	3mm Spacer	2	
17	TJ208	10mm Spacer	2	
18	TJ204	13.5mm Spacer	1	
19	GA110B-A	8 Section Grass Seed Roller (A)	4	
20	GA110B-B	8 Section Grass Seed Roller (B)	4	
	TJ192A	8 Outlet 1/2 Seed Feed Roller Kit consisting of the following:		
23	TJ209	15.4mm Spacer	2	
24	TJ213	39.5mm Spacer	3	
25	GA110B-A	8 Section Grass Seed Roller (A)	2	
26	GA110B-B	8 Section Grass Seed Roller (B)	2	

20.2 Feed Roller Kits Part Numbers Cont

Item	Part No.	Description	Qty.	Remarks
	TJ197C	10 Outlet 5mm Small Seed Feed Roller Kit consisting of the following items:		
31	TJ199	Stainless Steel Shim	20	
32	TJ200	5mm Small Seed Roller (White)	20	
32	TJ201	5mm Small Seed Roller (Yellow)	10	
33	TJ210	18mm Spacer	9	
35	TJ205	5mm Spacer	23	Includes 3 spare
36	TJ211	6.5mm Spacer	2	
36a	TJ219-1	Manifold Blanking Plug	3	Not shown
	TJ197B	10 Outlet 20 Section Seed Feed Roller Kit consisting of the following items:		
38	TJ207A	3mm Spacer	1	
39	GA110	20 Section Seed Roller	5	
	TJ197D	10 Outlet Seed Feed Roller Kit consisting of the following items:		
43	TJ211	6.5mm Spacer	2	
44	TJ214	5.3mm Spacer	9	
45	GA110B-A	8 Section Grass Seed Roller (A)	5	
46	GA110B-B	8 Section Grass Seed Roller (B)	5	
	TJ197E	10 Outlet 1/2 Seed Feed Roller Kit consisting of the following items:		
50	TJ209	15.4mm Spacer	2	
51	TJ205	5mm Spacer	2	
52	TJ213	39.5mm Spacer	4	
53	GA110B-A	8 Section Grass Seed Roller (A)	3	
54	GA110B-B	8 Section Grass Seed Roller (B)	2	

21.0 Hydraulic Fan - Parts (Diagram)

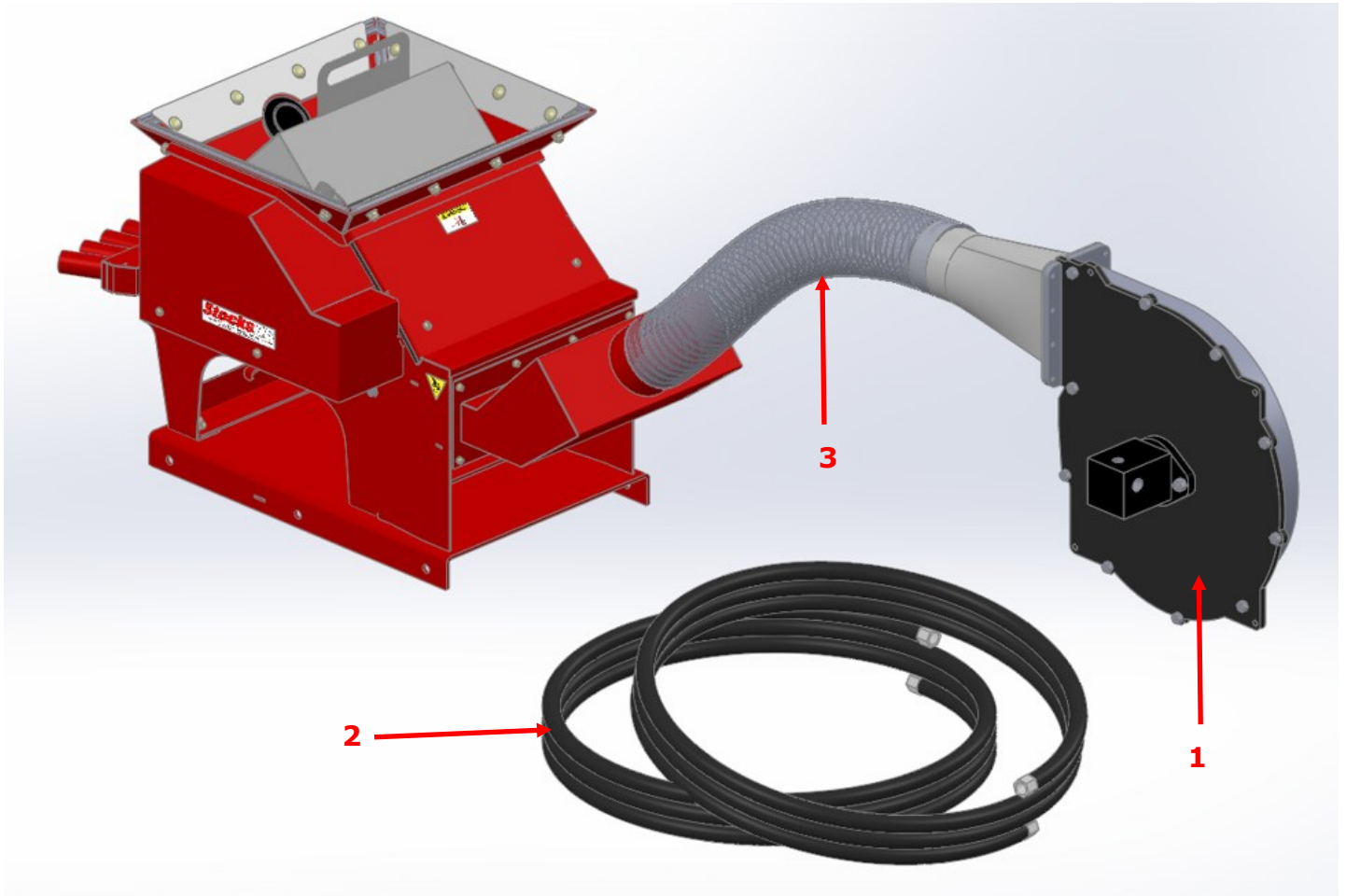

21.1 Hydraulic Fan - Parts List

Item	Part Number:	Description	Qty
1	97APC5452	CRARY HYDRAULIC FAN	1
2	97APC5454	HYDRAULIC FAN HOSE KIT (Pair)	1
3	97APC5456	4 INCH PVC DUCTING	1

22.0 Turbo Jet Hydraulic Version - Parts (Diagram)

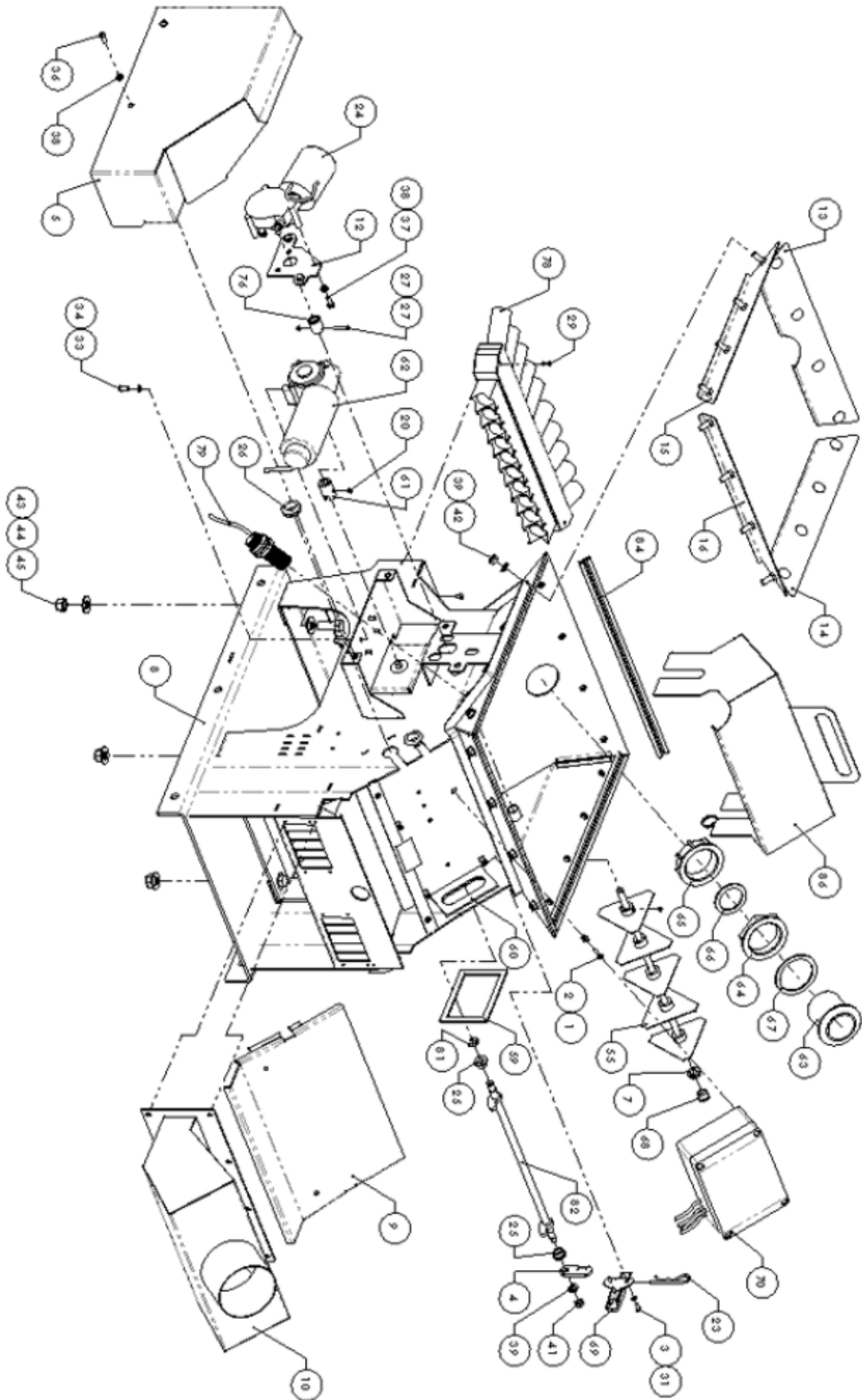

22.1 Turbo Jet Hydraulic Version - Parts List

ITEM NO	PART NUMBER	DESCRIPTION	QTY
1	89APP1011	JETPRESS CAN 015 SQUARE HEADED SCREW GROMMET	7
2	89APP1012	NO. 8 x 1" POZI SELF TAPPING PAN HEAD SCREW ST-ST	4
3	89APP1015	NO. 8 HALF INCH POZI SELF TAPPING PAN HEAD SCREW ST-ST	9
4	97APC1432	DOOR LATCH CATCH PLATE	1
5	97APC1433	MOTOR GUARD WELD ASSEMBLY	1
7	97APC1462	CHASSIS WELD ASSEMBLY - 2ND STAGE	1
8	97APC5133	BASE PLATE	1
9	97APC5140	REAR COVER AND GUARD	1
10	97APC1444	AIR BOX WELD ASSEMBLY	1
11	97APC5149	BASE PLATE WELD ASSEMBLY	1
12	97APC5170	AGITATOR PLATE	1
13	97APC5177	HOPPER DOUBLER PLATE MANIFOLD SIDE WELD ASSEMBLY	1
14	97APC5178	HOPPER DOUBLER PLATE CASSETTE SIDE WELD ASSEMBLY	1
15	97APC5179	HOPPER DOUBLER PLATE MOTOR SIDE WELD ASSEMBLY	1
16	97APC5180	HOPPER DOUBLER PLATE FAN SIDE WELD ASSEMBLY	1
17	98APP1024	TURBO JET DECAL	2
18	98APP1025	STOCKS AG DECAL	1
19	98APP1025	STOCKS AG DECAL	1
20	FJ008A	M6 x 6 CONE POINT HEX SOCKET GRUB SCREW ST/ST	1
21	FJ033A	M8 FEMALE PLASTIC KNOB - BLACK	2
22	FJ418A	SPLIT RING	1
23	FJ419A	R PIN	3
24	GA046	AGITATOR MOTOR 12VDC	1
25	GA103	FLANGED PVC BUSH	2
26	GR003	GROMMET	2
27	M3-003	M3 x 25 HEX HEAD SET SCREW ST/ST	1
28	M3-008	M3 NYLOC NUT T TYPE ST/ST	1
29	M4-001A	M4 x 12 BUTTON SOCKET HEAD SET SCREW ST/ST	2
30	M4-003	M4 x 10 SOC CAP HEAD SET SCREW ST/ST	4
31	M4-006	M4 FLAT WASHER FORM A ST/ST	13
32	M5-001	M5 x 8 HEX SOCKET BUTTON HEAD SCREW ST/ST	2
33	M5-004	M5 x 12 HEX HEAD SET SCREW ST/ST	4
34	M5-014	M5 FLAT WASHER FORM A ST/ST	4
35	M5-015	M5 REPAIR WASHER BZP	1
36	M6-003	M6 x 16 HEX SOCKET BUTTON HEAD SET SCREW ST/ST	4

22.2 Turbo Jet Hydraulic Version - Parts List continued

ITEM NO	PART NUMBER	DESCRIPTION	QTY
37	M6-004	M6 x 16 HEX HEAD SET SCREW ST/ST	5
38	M6-016	M6 FLAT WASHER FORM A ST/ST	9
39	M8-010	M8 FLAT WASHER FORM A BZP	17
40	M8-012	M8 REPAIR WASHER BZP	2
41	M8-014	M8 NUT BZP (M8-014)	1
42	M8-019	M8 NYLOC NUT T TYPE BZP	16
43	M12-004	M12 x 35 BZP HEX HEAD SET SCREW	4
44	M12-008	M12 FLAT WASHER FORM C BZP	8
45	M12-014	M12 NYLOC NUT T TYPE BZP	4
46	MD021	ROTATION ARROW DECAL	1
47	MD024	"MADE IN BRITIAN` DECAL	1
48	MD027	STOCKS AG DECAL	1
49	MD038	SERIAL NO DECAL	1
50	MD051	WARNING DECAL	1
51	MD051	WARNING DECAL	1
52	MD051	WARNING DECAL	1
53	MD051	WARNING DECAL	1
54	MM019	LOOP LINK CHAIN	1
55	TJ021A	AGITATOR PADDLE ASSEMBLY	5
56	TJ038	STRIP SEAL	1
57	TJ038	STRIP SEAL	1
58	TJ038	STRIP SEAL	2
59	TJ040	SELF ADHESIVE FEED BLOCK GASKET	1
60	TJ041	SELF ADHESIVE JUNCTION BOX GASKET	1
61	TJ043A	MOTOR DRIVE COUPLING - SLOTTED	1
62	TJ044B	12 VDC FEED MOTOR	1
63	TJ050	TANK OUTLET FOR DRAIN BUNG	1
64	TJ051	PVC NUT FOR DRAIN BUNG	1
65	TJ052	BLANKING CAP FOR DRAIN BUNG	1
66	TJ053	RUBBER GASKET FOR BLANK CAP	1
67	TJ054	RUBBER GASKET FOR DRAIN BUNG	1
68	TJ055-1	PVC BLANKING PLUG	1
69	TJ103	OVER CENTRE LATCH	1
70	TJ119D	JUNCTION BOX MKII	1
72	TJ126A	HOPPER 240L	1
73	TJ128	LID	1
74	TJ129	NECK RING	1
75	TJ130	PVC CALIBRATION TRAY	1
76	TJ137	AGITATOR DRIVE SHAFT COUPLER	1
77	TJ138A	AGITATOR SHAFT	1
78	TJ217A	10 OUTLET FEED MANIFOLD ASSEMBLY	1
79	TJ251A	HOPPER LEVEL SENSOR	1

22.3 Turbo Jet Hydraulic Version - Parts List continued

ITEM NO	PART NUMBER	DESCRIPTION	QTY
81	TJ433	E TYPE CLIP	1
82	TJ440A	DOOR RELEASE SHAFT WELD ASSEMBLY	1
83	TJ467-1	WHITE `P` SEAL STRIP	4
84	TJ467-1	WHITE `P` SEAL STRIP	2
85	TJ467-1	WHITE `P` SEAL STRIP	2
86	TJ472A	HOPPER BAFFLE WELD ASSEMBLY	1
87	TJ1285	NO.10 x 1 INCH HEX HEAD SELF TAPPING SCREW ST/ST	1

