

StocksAG

Fan Jet Mini i-CON

ORIGINAL OPERATING MANUAL & PARTS LIST



Read carefully before installation and operation

This document must not be copied duplicated or distributed without prior consent.
All intellectual property and patent rights apply.



Stocks Ag Limited.

Cromwell Road, Wisbech, Cambridgeshires, PE14 0SD, UK
01945 464909 sales@stocks-ag.co.uk www.stocks-ag.co.uk



Index

Section		Page
	E.C. DECLARATION OF CONFORMITY	4
	UKCA. DECLARATION OF CONFORMITY	5
1.0	General Information	6
1.1	Technical Data	6
1.2	Intended Use	6
1.3	Unintended Use	6
1.4	Machine Identification	7
1.5	Warranty	7
2.0	Safety	8
2.1	Safety Warning Decals	9
3.0	Emergency Stop Instructions	10
4.0	Storage	10
5.0	PVC Waterproof Covers	10
6.0	Disposal	10
7.0	General Maintenance	11
7.1	Before Use	11
7.2	Daily Checks	11
7.3	After Each Use	11
8.0	Installation Guide	12
8.1	ATV Fitting Kit	12
8.2	UTV Fitting Kit	12
8.3	Mounting Plate	13
9.0	Machine Components	14
9.1	Feed Motor	14
9.2	12v Disc Motor	14
9.3	GPS Sensor	14
9.4	Main Power Cable	14
9.5	Instrument Lead	14
9.6	Spring Finger Switch	14
9.7	Hopper Level Sensor	14
10.0	Hopper Emptying Procedure	15
10.1	Clearing A Blockage	15
11.0	i-CON Control System	16
11.1	Wiring Diagram	16
11.2	Electrical Connections	16
12.0	i-CON Instrument Functions	17
12.1	Precision Farming Software Access	17

Index

Section		Page
13.0	i-CON Calibration	18
13.1	At The Machine	18
13.2	At The i-CON Instrument	18
13.3	Manual Calibration	19
13.4	GPS Speed	19
13.5	Common Calibration	19
13.6	Ready For Work	19
14.0	Setting The Feed Rate	20
14.1	Feed Roller Configuration	20
15.0	Setting The Headland Deflectors	21
15.1	Spread Width And Pattern	21
16.0	Calibration Hopper	22
16.1	Fitting Instructions	22
17.0	Fan Jet Mini Parts (Diagram)	23
17.1	Fan Jet Mini Parts List	24
17.2	Fan Jet Mini Parts List Cont	25

E.C. DECLARATION OF CONFORMITY

Machine Type: Mounted Agricultural Implement - Pellet and Seed application broadcasters

Model(s):

Fan Jet Pro	All Variants and Versions
Fan Jet Pro Plus	All Variants and Versions
Fan Jet Twin	All Variants and Versions
Fan Jet Mini	All Variants and Versions
Fan Jet Duo	All Variants and Versions
Turbo Jet	All Variants and Versions
Rotor Meter	All Variants and Versions
Rotor Meter Air Force	All Variants and Versions
Micro Meter	All Variants and Versions
Maxi Meter	All Variants and Versions

Serial No.

Manufacturer: Stocks Ag Ltd
Cromwell Road
Wisbech
Cambridgeshire PE14 OSD
United Kingdom

This is to declare that the above machine conforms to the relevant Essential Health and Safety Requirements of the Machinery Directive 2006/42/EC, implemented in the United Kingdom by Statutory Instrument 2008 No. 1597 – The Supply of Machinery (Safety) Regulations 2008 as amended.

The following standards have been applied in the design and construction of this machine:

BS EN ISO 12100:	2010	Safety of machinery – General principles for design – Risk assessment and Risk reduction.
BS EN ISO 4254-1:	2015	Agricultural machinery – Safety - General requirements.
BS EN ISO 4254-8:	2018	Agricultural machinery. Safety - Solid fertilizer distributors
BS EN ISO 13854:	2019	Safety of machinery – Minimum gaps to avoid crushing of parts of the human body.
BS EN ISO 13857:	2019	Safety of machinery – Safety distances to prevent hazard zones being reached by the upper and lower limbs.

The manufacturer stated above holds the technical file for this machine.

Signed on behalf of Stocks Ag Ltd

Name:..... J Woolway

Date: 06th August 2020

Position: Managing Director



t. +44 (0) 1945 464909 f. +44 (0) 1945 464985 e. sales@stocks-ag.co.uk



UKCA. DECLARATION OF CONFORMITY

Machine Type: Mounted Agricultural Implement - Pellet and Seed application broadcasters

Model(s):	Fan Jet Pro	All Variants and Versions
	Fan Jet Pro Plus	All Variants and Versions
	Fan Jet Twin	All Variants and Versions
	Fan Jet Mini	All Variants and Versions
	Fan Jet Duo	All Variants and Versions
	Turbo Jet	All Variants and Versions
	Rotor Meter	All Variants and Versions
	Rotor Meter Air Force	All Variants and Versions
	Micro Meter	All Variants and Versions
	Maxi Meter	All Variants and Versions

Serial No.

Manufacturer: Stocks Ag Ltd
Cromwell Road
Wisbech
Cambridgeshire PE14 OSD
United Kingdom

This is to declare that the above machine conforms to the relevant Essential Health and Safety Requirements of the Machinery Directive 2006/42/EC, implemented in the United Kingdom by Statutory Instrument 2008 No. 1597 – The Supply of Machinery (Safety) Regulations 2008 as amended.

The following standards have been applied in the design and construction of this machine:

BS EN ISO 12100:	2010	Safety of machinery – General principles for design – Risk assessment and Risk reduction.
BS EN ISO 4254-1:	2015	Agricultural machinery – Safety - General requirements.
BS EN ISO 4254-8:	2018	Agricultural machinery. Safety - Solid fertilizer distributors
BS EN ISO 13854:	2019	Safety of machinery – Minimum gaps to avoid crushing of parts of the human body.
BS EN ISO 13857:	2019	Safety of machinery – Safety distances to prevent hazard zones being reached by the upper and lower limbs.

The manufacturer stated above holds the technical file for this machine.

Signed on behalf of Stocks Ag Ltd

Name:  J Woolway

Date: 01st December 2020

Position: Managing Director

t. +44 (0) 1945 464909 f. +44 (0) 1945 464985 e. sales@stocks-ag.co.uk



1.0 General Information

Congratulations on your Fan Jet Mini purchase:

Please check the machine for any transport damage upon receipt and advise your supplier of any problems immediately. Late claims regarding any damage may be rejected.

Specifications, descriptions and illustrations in this manual are accurate at the time of this publication but may be subject to change. This manual is correct at the time of printing but Stocks-AG reserve the right to change and improve them. This machine is designed with safety in mind. Maintenance and servicing in accordance with this manual will ensure safe operation and reliability of your machine for many years.

This Operating Manual forms part of the machine and must be readily available for the operator who must read and follow the points covered before use.

1.1 Technical Data

Model: Fan Jet Mini i-CON

Hopper capacity: 65 litre or 130 litre

65 litre machine:

Net weight: 40kg

Dimensions: (WxDxH) 50 x 56 x 82cm
(boxed 52cm x 58cm x 100cm)

130 litre machine:

Net weight: 45kg

Dimensions: (WxDxH) 60 x 60 x 90cm
(boxed 62cm x 62cm x 113cm)

Max spreading width: 12m

Recommended working width: 3-12m

Operating Voltage: 12v

Power Requirement: 30 amps (continuous supply)

Motor outputs: 360 watt

Max disc speed: 3700 rpm

***Noise level:** 85dB

1.2 Intended Use

This Fan Jet Mini i-CON has been designed for use in the agricultural, horticulture, and amenity sector to apply large dense slug pellets from 3-12m and various small seeds and granular products, to varying widths depending upon the seed or product density. Can also be used for game cover cropping and as a game feeder.

The applicator can be mounted to operate facing forwards or backwards. Often mounted on the rear of drills and sets of rolls to apply slug pellets.

Any other use is considered to be unintended and the manufacturer will not be liable for any resulting damage.

The manufacturer is not liable for any resulting damage if the machine is used for any other purpose than the intended use and also includes compliance with the conditions for operation, maintenance, and repairs prescribed within this instruction manual.

The applicable accident prevention regulations as well as the other generally safety-related, occupational health and road traffic regulations must also be observed.

1.3 Unintended Use

This machine is not designed to apply abrasive materials such as sand & grit or for applying salt products.

The operator alone bears the associated risk if used for non-intended use.

2.0 Safety

Ensure care is taken when lifting the machine. Safe lifting practice to be observed when handling as the net weight is over 25kg



- We advise safety shoes and protective gloves are worn when handling the machine.
- Assistance will be required when lifting or lowering the machine.
- Care to be taken to avoid crushing due to the weight of the machine.
- When lifting or fitting the machine on to a parent vehicle or implement ensure work is performed on level ground or flat surface to avoid slipping, stumbling or falling.

PERSONAL PROTECTION EQUIPMENT

It is the responsibility of the operator or maintenance engineer to ensure safe handling of the machine and the appropriate personal protection equipment must be worn for the material being applied and to prevent contamination to the machine or the environment.

⚠ WARNING! Ear protection required if working in close proximity to the machine as it exceeds 80dB.

PRODUCT APPLIED

If applying slug pellets or other toxic material and the parent vehicle has a closed cab the operator must ensure the cabin is always closed and the air filter system is in good order. If fitted to a UTV vehicle ensure the stability of the parent vehicle is not affected when the machine is in use. If in doubt contact the vehicle manufacturer for more information. After working the machine ensure that any unused product is returned safely to its original packaging. Stocks AG Ltd. does not accept any liability for the storage and use of the material being applied.

NOTE: If unsure contact your seed or product supplier for more information.

⚠ WARNING! Always observe all application standards and guidelines provided by the product manufacturer as some seed dressings and granular products may be toxic.

OPERATION AND MAINTENANCE

The machine may only be used, maintained and repaired by persons who have relevant experience or a machinery dealer who is aware of any risks involved. The applicable accident prevention regulations as well as the other generally safety related, occupational health and road traffic regulations must also be observed.

The manufacturer is not liable for any damage resulting from unauthorised modifications and the use of components and auxiliary parts. The machine must be checked regularly by the operator (before each use) for any damage, loose bolts or electrical connections, vibrations, unusual sounds, and to ensure they function correctly.

The machine must not be operated in wet weather conditions or during thunderstorms. Observe the generally applicable safety and accident prevention regulations. Always empty the hopper of toxic materials to prevent harm to humans and animals after each use and prior to storage.

⚠ WARNING! Do not put your hands inside the hopper when the agitator motor is turning as the agitator shaft inside the hopper rotates at high speed and is sharp and dangerous.

⚠ WARNING! Always isolate the power supply if servicing or leaving the machine unattended.

2.1 Safety Warning Decals

Important: Be aware of the safety warning below which are all relevant to this machine



⚠ WARNING!

Read and understand the Operators Manual instructions before operating this machine.

Operator errors can result in serious injury.



⚠ WARNING!

Danger due to thrown or flying objects.

Always maintain a safe distance whilst the machine is in operation.

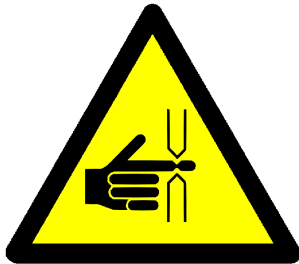

⚠ WARNING!

Risk of injury. Possible trapping point when tipping hopper.



⚠ WARNING!

Risk of injury.

Be aware the feed mechanism is powerful and can cause serious injury.



⚠ WARNING!

Keep Clear!

Maintain a safe distance from the machine when in operation.

Wear the appropriate protective personal equipment.



⚠ WARNING!

Do Not Jet Wash. This machine is not designed to withstand Jet Washing.

3.0 Emergency Stop Instructions

1. Power down the control system immediately by pressing and holding down the left-hand rubber end cap on the instrument control panel for approx. 2 seconds — then release to power off.
2. Disconnect the power supply by unplugging the power cable or removing the inline 40amp fuse.



4.0 Storage

Disconnect the power supply by unplugging the power cable or by removing the fuse fitted in the power cable.

It is the responsibility of the operator to ensure the hopper is empty after each use and cleaned thoroughly before storage.

Store in dry conditions to protect the machine and control system from moisture.

Always clean and spray electrical connectors with a moisture repellent spray when not in use for long periods.

5.0 PVC Waterproof Covers - Optional

Heavy duty White PVC cover fitted with eyelets and bungie cord for easy attachment.

65L Waterproof PVC Cover **Part No. LC65**

130L Waterproof PVC Cover **Part No. LC130**

Please contact your locals Stocks Ag dealer for more information.

6.0 Disposal

Ensure that any persons handling the machine are aware that the machine may have been used to apply toxic chemicals and so the appropriate personal protection equipment should be worn.

Ensure the hopper contents have been removed and any toxic residue removed and put back into a sealed container or disposed of in accordance with the manufacturers guidelines to eliminate any possible contamination of others or the environment.

Always adhere to the local disposal regulations paying particular attention to the plastics, rubber, and electrical components.

7.0 General Maintenance

⚠ WARNING! Always ensure the power supply is disconnected before any maintenance work or cleaning of this machine by unplugging the power cable or removing the 40amp fuse in the power cable.

Ensure the parent machine is stationary and parked on level ground before working on the machine.

The machine must be checked regularly by the operator for any damage loose bolts or electrical connections, vibrations, unusual sounds, and to ensure they function correctly.

⚠ WARNING! Protective clothing must be worn when applying or handling toxic products.

Always observe all guidelines provided by the product manufacturer with regards to handling, storage and disposal of products. Take care not to spill any product that could contaminate the machine or the environment ensuring any product removed from the machine is put back into its original container.

7.1 Before Use

1. Ensure the machine is securely mounted.
2. Check the power supply and ensure the power cable is connected direct to the vehicle battery.
3. Check the feed block assembly's to ensure the feed rollers are clean and replace any worn feed rollers.
4. Check the feed rollers rotate freely before starting work.

7.2 Daily Checks

1. Check the disc to motor shaft socket screws on the lower side of the spinning disc to ensure they are tight and the spinning disc turns with the motor.
2. Check the stainless disc for any wear or distortion and replace prior to use if necessary.
3. Check the feed block assembly's to ensure the feed rollers rotate freely.

7.3 After Each Use

1. Empty hopper and clean the machine thoroughly.
2. Disconnect the power supply.
3. Replace the PVC waterproof cover (if applicable).
4. Store in dry conditions to protect the machine and control system from moisture.

⚠ WARNING!
DO NOT JET WASH THIS MACHINE.



8.0 Installation Guide

Safe lifting practice to be observed when handling the machine as the net weight is over 25kg.

Safety shoes and protective gloves to be worn when handling the machine.

With a full hopper the 65L machine could weigh in excess of 90kg and the 130L machine 95kg and so ensure the machine is securely attached to a suitably strong rigid mounting point.

If unsure seek advise from the parent machine manufacturer or supplier.

Locally fabricated mounting frames are not the responsibility of Stocks AG Ltd

NOTE: The machines can be operated facing forwards or backwards.

Ensure the disc height is a minimum of 1 metre above the crop canopy or the ground – more height may improve the maximum spread width.

Ensure the power cable is connected direct to the parent vehicle 12v battery and the fuse is fitted correctly.

Always adhere to Health and Safety guidelines when mounting or fabricating an appropriate mounting frame and always wear suitable protective clothing.

8.1 ATV Fitting Kit - Optional

ATV fitting Kit available: Part No. FJ-005-BKT (available through your local dealer).

NOTE: Always check specification of any ATV rear carrier before ordering.

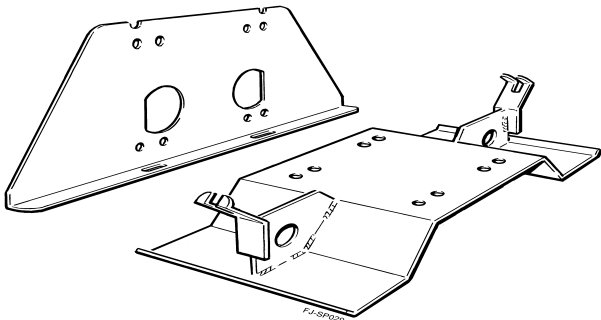

Many rear carriers will not have the load carrying capacity to support the weight of a fully laden Fan Jet mounted on an ATV kit. Please check with your ATV supplier as modification may be available.

The Stocks ATV Kit provides a quick and easy way to attach your Fan Jet to the rear carrier of your ATV. Designed as a universal fitment to elevate the Fan Jet to gain more height to the spinning disc.

The formed steel base plate with quick fit clamps and jacking screws to mount the machine to the base plate and to adjust the angle of the disc when the ATV is fully laden.

The kit includes an operator protection plate which bolts onto the back frame of the machine plus a short power and connector cable to maximise the power at the disc motor.

These are to be fitted rather than the standard length cables supplied with the Fan Jet machine.

8.2 UTV Fitting Kit - Optional

Part No. FJ-005-UTV (available through your local dealer).

The cost option UTV kit available for most UTV fitments. Offering a sturdy fitting option with 4 hooked anchor points with hand release fittings. One piece tubular steel construction with detachable machine mounting plate. Fixed fork lift point safe and easy lifting on and off vehicle.

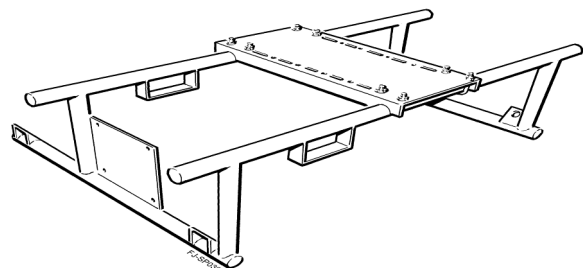

⚠ WARNING! The i-CON instrument is not waterproof and so will need to be protected.

8.3 Mounting Plate

Mount the machine using the tipping base plate. This has 4 holes in the base to take M12 bolts (see below) use these to attach to the parent vehicle. The base plate can be repositioned to fit the holes in the back of the machine to attach to a vertical mounting point – use whichever is best for you.

Ensure there is sufficient room to tip the hopper for emptying and ensure any potential trapping points are noted taking care not to trap hands or fingers.

The tipping base plate is attached to the chassis by 2 bolts and spacers which act as the pivot, and a removable steel pin secured by an 'R' clip. There are 2 positions for the pin – use these to help level the Fan Jet.

The machine must be on level ground or flat surface before tipping the hopper to avoid the hopper accidentally tipping forward once the tipping pin has been removed.

To tip the hopper, remove the pin whilst supporting the hopper, lower gently when emptying the hopper.

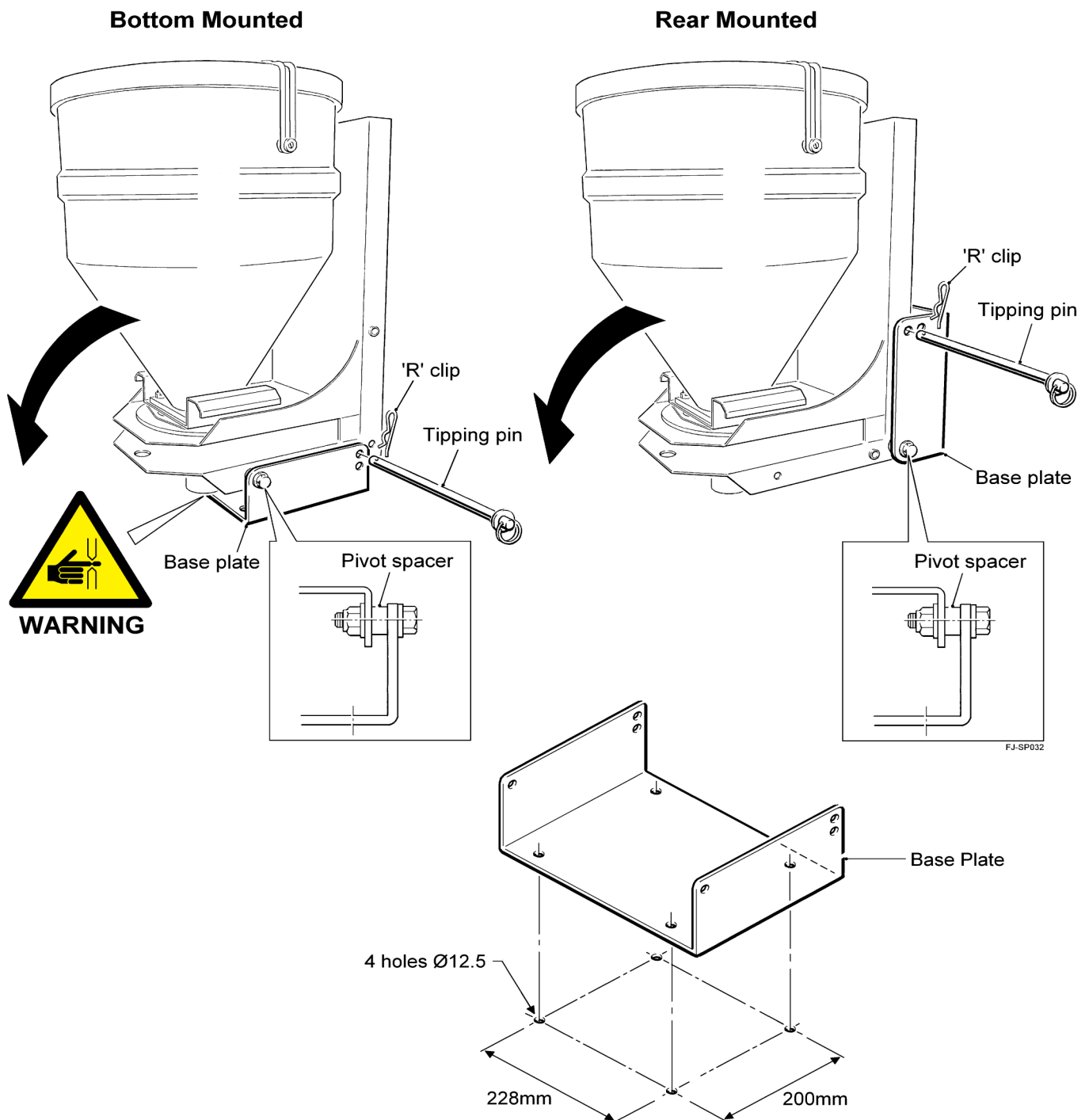

Additional Base Plates available: Part No. FJ514B

9.0 Machine Components

9.1 Feed Motor

The feed motor can be turned ON or OFF, either manually via the head unit, or automatically by the remote mounted spring finger switch which can be fitted to the linkage or the implement. The feed motor must be switched ON via the head unit for the spring finger switch to work automatically.

9.2 12v Disc Motor

The disc motor can be switched on and off and the disc speed adjusted on the instrument panel.

9.3 GPS Sensor

Small and compact with integrated magnetic base for ease of fitting to tractor cab or suitable mounting position. Fitted with a 5m lead which plugs into the i-CON instrument connector cable.

9.4 Main Power Cable

The power cable should connect directly to the vehicle battery posts to ensure adequate 12v supply to the disc motor. The in-line is 25 amp. This 7m power cable connects from the battery to the power input flylead on the machine.

9.5 Instrument Lead

The 6m instrument lead connects to the junction box of the Fan Jet, and runs to the control panel in the tractor cab.

NOTE: Extension power and instrument cables available if required.

Please contact your local Stocks AG dealer for more information.

9.6 Spring Finger Switch

The switch should be mounted to a suitable place on the implement or linkage of the tractor, thus deflecting the spring, and automatically switching the feed motor off or on accordingly as the circuit is made or broken.

Position the finger switch so that the tip of the spring comes into contact with the moving part of the implement or linkage when lifted out of work, and remains deflected until the implement is lowered back into work.

NOTE. Ensure that there is sufficient and positive deflection on the spring to prevent accidental switching ON or OFF if the implement moves slightly up or down in work.

The standard wiring as supplied for this switch is when the spring is at rest, the feed motor will run normally. If required, the switch can work in the opposite mode by changing the position of the 2 wires inside the switch so that the switch is out of work when the sprung is at rest. To change over remove the PVC cover plate held in position with the retaining screw to access the wiring terminals. Remove the 2 wires from terminals 13 and 14 and re-connect to terminals 21 and 22 (nearest the gland nut) then re-fit the PVC cover plate.

NOTE: The area meter also stops when the feed motor stops.

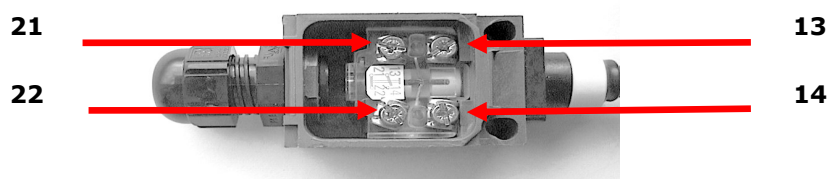

9.7 Hopper Level Sensor

The instrument will alarm once the product in the hopper falls below the level of the sensor.

10.0 Hopper Emptying & Removal Procedure

Removing the hopper for cleaning and maintenance.

Ensure appropriate personal protection equipment is worn for the product being applied.

Ensure there is sufficient room to tip the hopper for emptying and ensure any potential trapping points are noted, taking care not to trap hands or fingers.

NOTE: The machine must be on level ground or flat surface before tipping the hopper to avoid the hopper accidentally tipping forward once the tipping pin has been removed.

Release the rubber lid retaining straps and remove the lid.

To tip the hopper, remove the R Clip and washer. Whilst supporting the hopper, remove the Tipping Pin, lowering gently when emptying the hopper through the three outlet holes in the top. When replacing the hopper ensure the gasket fitted under the base of the hopper is in good order.

Replace if damaged: Part number FJ017S.

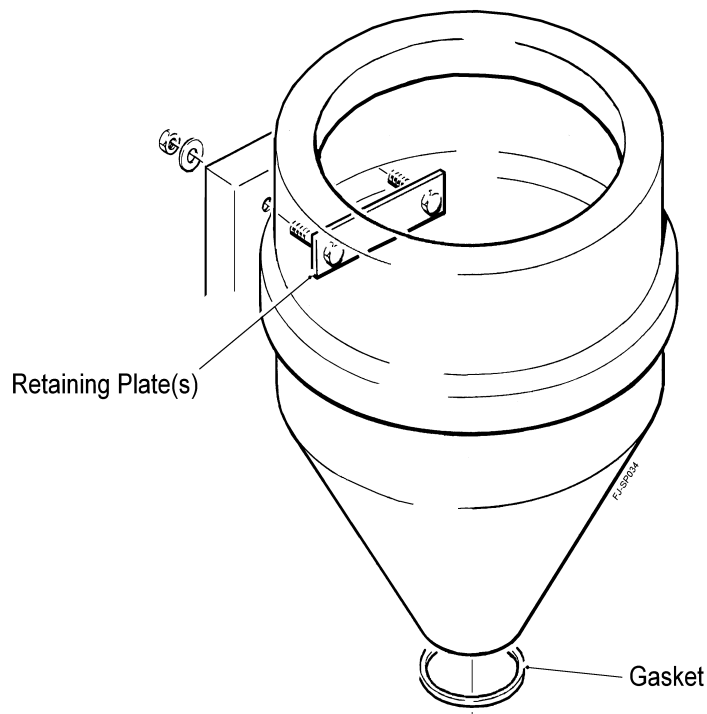

10.1 Clearing A Blockage

Switch off the main power switch on the control panel.

Ensure the parent machine is stationary, switched off, and parked on level ground.

Ensure the main power switch on the control panel is off and unplug the 2 core power supply cable from the control box or disconnecting the power cable from the vehicle battery.

Ensure appropriate personal protection equipment is worn for the product being applied.

Ensure any product removed is put back into its original container. Care to be taken not to spill any product that could contaminate the environment.

11.0 i-CON Control System

All control system components integral to the Seed Applicator Unit are factory fitted in.

The Instrument has a 4.3" Colour Touch Screen which has 4 basic menu keys.

Separate heavy-duty power cable and head unit leads interconnect the tractor and the Seed Applicator Unit.

The following components need to be installed during fitment (packed in hopper from factory).

- i-CON Instrument: TJ117C
- Instrument cables: TJ118C and TJ242A
- Power Cables: FJ107E
- GPS Receiver: TJ255B
- Cut out Switch: TJ252

11.1 Wiring Diagram

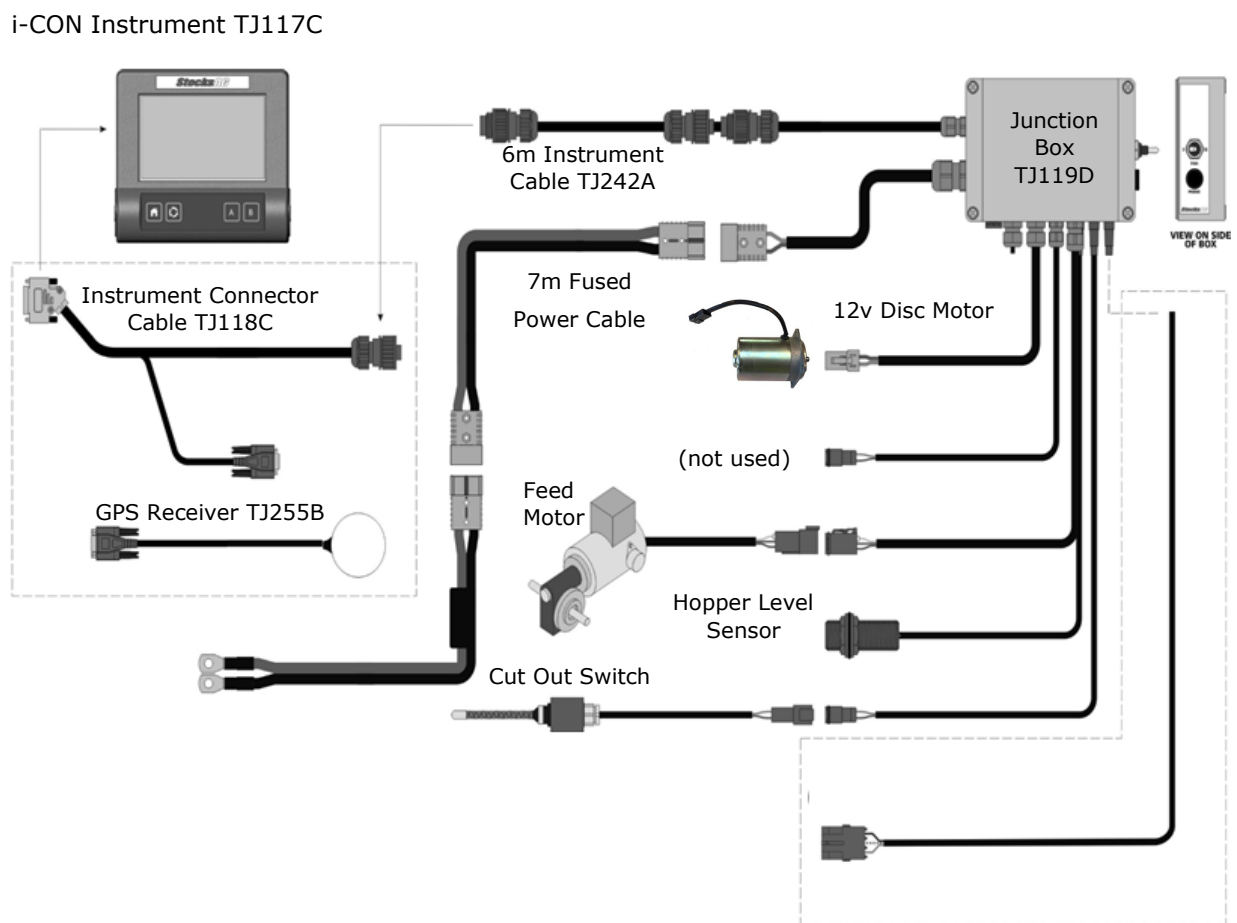

11.2 Electrical Connections

Ensure the power supply cable is connected directly to the vehicle battery to ensure maximum power.

Connect the positive wire (fused) to the positive (+) terminal and negative earth connection to the negative (-) terminal. The disc should rotate in a clockwise direction when viewed from above.

Failure to connect to the vehicle battery may result in control function problems and possible damage to the vehicle battery and charging system must be in good condition to achieve the best results. All cables and controls are fitted with matching plugs and sockets. Extension cables available.

Any modification to the wiring, fuse holder or controls will invalidate any warranty claim and may affect the performance of the Fan Jet.

Always replace any blown fuse with the same rated fuse as the original one fitted.

12.0 i-CON Instrument Functions

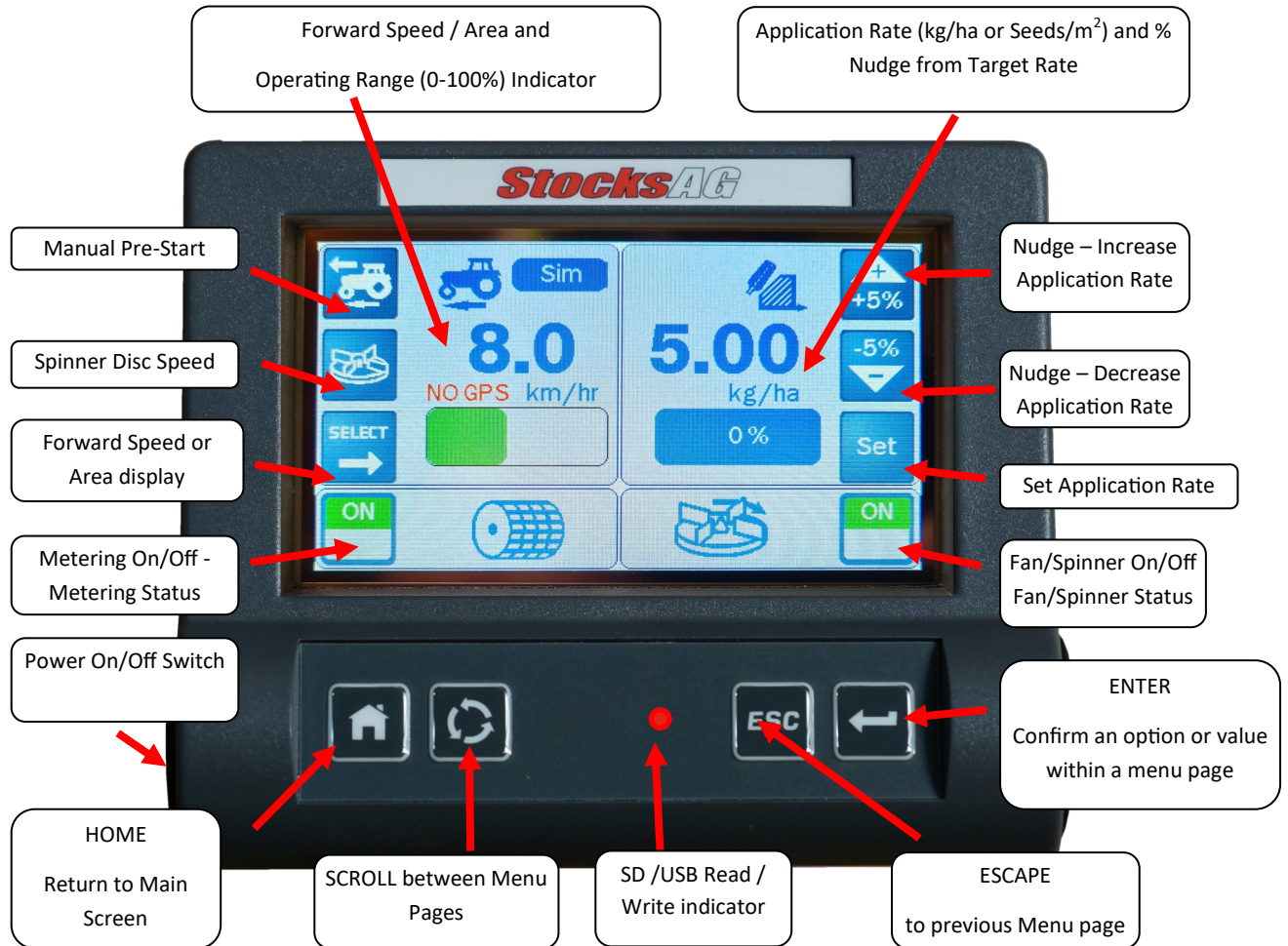

- Seed Application Rate (kg/ha or Seeds/m²).
- Forward Speed (km/hr).
- Minimum/Maximum Forward Speed indicator with alarms, (beyond which the programmed seed rate cannot be maintained).
- Metering Unit Status (On/Off) and Alarm.
- Fan (or Spinner - depending on installation) Status (On/Off) and Alarm.
- Hopper contents (kg) and Low Level Alarm.
- Part and Full (Job) Totals for Area (ha), Product dispensed (kg) and hours worked.
- Grand Total for Area (ha), Product (kg) and hours worked.

Other features include:

- Simple and intuitive touchscreen Alarm codes and diagnostic displays in the event of system malfunction.
- Menus for Forward Speed / Product calibration and adjustment.
- Pre-start' - ensures seed delivery begins immediately the drill enters work (user-programmable).
- Rate 'Nudge' - on-the-move rate adjustment in pre-set increments (user-programmable).

NOTE: A comprehensive control system user guide also supplied (packed with the i-CON instrument).

12.1 Precision Farming Software - Optional

The instrument can be unlocked to activate the precision farming program as a cost option.

This is something that can be requested when the machine is purchased or can be added at a later date.

Please contact your local Stocks dealer for more details.

13.0 i-CON Calibration

You will need a suitable container to collect the product or seed when calibrating and an accurate set of scales which weighs in grams.

13.1 At The Machine

1. Fit the calibration hopper and feed block assembly.
2. Position a suitable collection tray directly underneath the calibration hopper to catch the product.
3. Place a few kilograms of seed in the hopper.

13.2 At The i-CON Instrument

1. Switch the spinning disc off at the instrument.
2. Switch the head unit ON via the left hand side push button – wait until the start-up routine has finished and displays the main “home screen”.
3. Scroll through  to the Setup Menu and select the Applicator Icon.
4. Adjust the implement width accordingly - refer to the RDS manual, Set Implement Width.

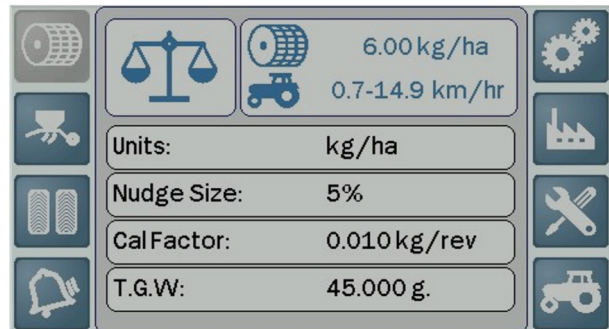

5. Ensure the correct application rate is entered – select and adjust accordingly, refer to the RDS manual, Setting the Application Rate.

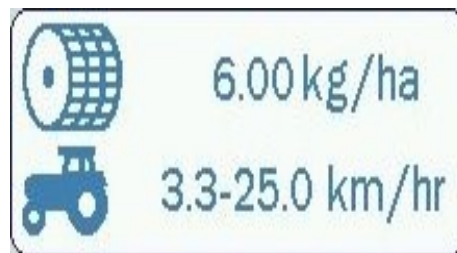



6. Ensure the feed roller setup is appropriate for the intended product or seed type, application rate and forward speed range for application.

7. The instrument calculates the calibration factor from the working width, target application rate, and the metered weight delivered whilst calibrating. If however as a result of the calibration routine, you find that you cannot achieve your desired field speed, displayed in the top right corner of the screen, then re-configure the feed roll assembly and repeat the calibration procedure.

8. Prime the feed rolls with product by pressing and holding briefly the prime button on the junction box - this will ensure a higher initial calibration accuracy, empty the contents of the tray back into the hopper.

9. For an **Auto Calibration** from the Product Setup page, touch 

10. Touch  and enter the quantity that you wish to dispense for calibration purposes. You can enter the quantity in grams if preferred. The CAL factor will however, still be calculated in kg/rev.

11. Touch on the screen page 

12. After the  key the motor runs at the calibration speed (calculated from the Simulated Forward Speed, Width, Application Rate and current calibration factor).

13. The dispensed weight (based on the current calibration factor) is displayed.

14. Weigh the product dispensed and then enter the measured weight, and press 

15. A new calibration factor is then re-calculated and displayed.

16. Your in-field min and max speeds will be displayed as per the image to the right hand side. If you find that you can not achieve your desired field speed, then re-configure the feed roll assembly and repeat the calibration procedure **NOTE:** Recommended min speed 0.8kph - 1.2kph (if not see feed roller configuration).

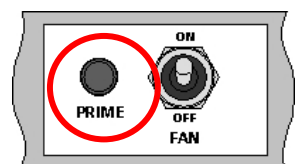

17. Touch  to save the new factor, it is advised to repeat the calibration two more times to ensure accuracy.

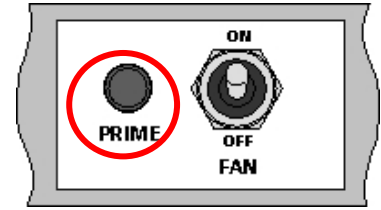

13.3 Manual Calibration

1. Switch off the spinning disc at the Fan on/off switch on the machine.
2. Press and hold the Prime button on the junction box, the larger the quantity dispersed the higher the accuracy the final calibration factor will be, release the prime button once sufficient product has been dispensed.
3. The estimated dispensed weight (based on the current calibration factor) is displayed.



4. Weigh the product dispensed and then enter the measured weight, and press .
5. A new calibration factor is then re-calculated and displayed.
6. Your in field min and max speeds will be displayed. If you find that you cannot achieve your desired field speed, then re-configure the feed roller assembly and repeat the calibration procedure.
7. Touch  to save the new factor, it is advised to repeat calibration 2 more times to ensure accuracy.

13.4 GPS Speed

The i-CON control system is automatically configured to run with GPS receiver supplied and is a simple plug and play device. This system only works outside and if you are not receiving a GPS signal an alarm will displayed on the main screen indicating NO GPS.

13.5 Common Calibration Mistakes

- Ensure you enter the width and required rate correctly – that the decimal point is in the correct position. If the rate is 2.5 kg/ha, enter 2.5. (not 25 - which is 25kg/ha).
- Remember to deduct the weight of the collection bag or bucket – weigh only the contents.
- Ensure you work in grams – not kilograms.
- Ensure you are working in the mode required – either Kilograms per Hectare or Seeds per Square Metre. The standard default mode for the i-CON is in Kgs/Ha and you will have to reconfigure the display if you want to display Seeds per Square Metre. You do not need to enter or change the TGW if working in Kgs/Ha – only if working in Seeds per Square Metre - Refer to the RDS manual, Units and TGW.
- Ensure you check the minimum and maximum speeds displayed, and that they are sensible for your field operation. This is the speed range that the i-CON can maintain the required application rate, and depends on the width of your machine, the application rate required, and the type and configuration of feed rolls. Fitted.
- Ensure that the speed range will work for you in the field – ensure that your target forward speed will not be close to either the minimum or the maximum of the range, and that you have some reserve of speed range above and below the in-field forward speed. Ideally your forward speed will be in close to the middle of the range.
- If the minimum is too high, for example 4kph then the feed motor will be running too slowly if your forward speed drops towards the minimum as you set in and lift out of work, and this could result in missed patches (although the alarm will trigger when either the minimum or maximum speed is reached).
- If the indicated speed range does not work for your operation, you must change the feed roll configuration or the type of feed roll to apply more or less seed, per revolution of the feed mechanism, as required. Once completed, recalibrate and note the new speed range.

13.6 Ready For Work

Remove the Calibration Hopper and re-fit the feed block into the machine.

Ensure the feed motor is engaged and runs freely before filling the hopper and starting work.

Ensure the disc/Fan switch at the junction box is switched to the ON position.

14.0 Setting The Feed Rate

The feed rate is adjusted by the feed motor speed and by fitting different feed roller combinations. Each combination giving different feed rates of material per revolution. Refer to the Calibration Procedure page and with the appropriate feed rollers fitted, follow the instructions. You may have to change the feed rollers to obtain the application rate within a sensible forward speed range which is calculated during calibration procedure.

14.1 Feed Roller Configuration

The machine is fitted 10 white 5mm polyurethane 18 tooth feed rollers as standard these have a stainless steel drive disc embedded. Depending on the combination of required seeding rate, implement width and forward speed 2 to 10 feed rollers can be fitted with maximum rates achieved by fitting all 10 feed rollers. The black 5mm wide spacers supplied are the same width as the white feed rollers and used to replace feed rollers as required.

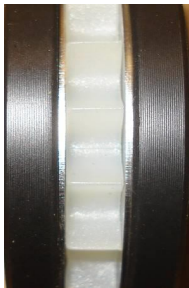

NOTE: Always ensure a stainless disc is fitted to each side of the set of 1,2,3,4 or 5 feed rollers used in each half of the feed block. They are important and needed to reduce friction between the feed rollers and the plastic spacers.

For higher outputs or applying large seeds or granules the machine is also supplied with 2 larger 8 section feed rollers and spacers to allow 1 or 2 to be fitted as required. The feed rollers are easily changed by removing the feed block as follows.

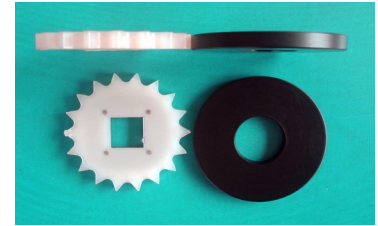

Photo below showing feed block assembly with 6 feed rollers and 6 blacking spacers fitted.

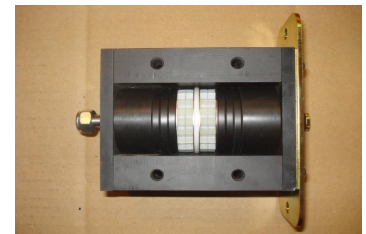
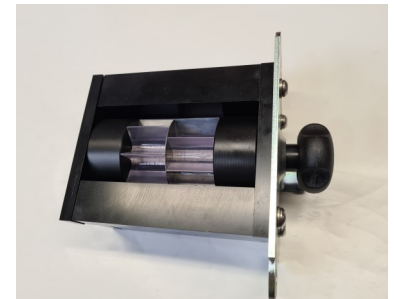

Photo Below showing feed block assembly with 2 larger 8 section feed rollers fitted.

NOTE: Empty the hopper completely before removing the feed block.

1. Undo and remove the 2 black plastic knobs holding the feed block in place.
2. Slide the complete mechanism out.
3. Undo and remove the 4 socket head screws on the end of the housing opposite the retaining plate and remove the end plate.
4. Slide the rollers and spacers off the shaft, and replace with the alternative rollers and spacers in the required combination.
5. Refit the end plates and re-fit the feed block and black plastic knobs.



When re-fitting the end plates to the feed block after changing the configuration, the end plate should be able to fit flush with the feed block by hand, without having to pull it home with the socket head screws.

NOTE: You should be able to rotate the feed shaft with your fingers – if it feels excessively tight, check the feed roller and spacer composition or call Stocks Ag for advice.

⚠ WARNING! Always observe all application standards and guidelines provided by the product manufacturer as some products may be toxic. If unsure contact your supplier for more information.

15.0 Setting The Headland Deflectors

Adjustable deflectors that reduce the exit aperture from the disc are incorporated into the Fan Jet to physically limit the spread width for headland control. Undo the black plastic knob at the rear of the chassis and slide each deflector around the disc as far as required to prevent chemical granules from entering a watercourse of grass margin. Re-tighten the locking knob.

NOTE: Use the motor disc speed in conjunction with the deflectors, and the bias adjustment.

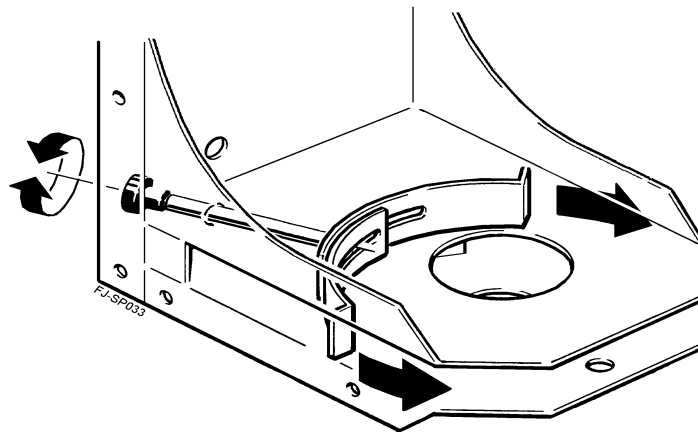

15.1 Spread Width And Pattern

BASIC RULE. The spread width is dependent upon the density of the granule or seed, and the disc speed (plus other factors).

Large, dense granules and seeds with a high disc speed give the maximum spread width – small, light granules and seeds will not spread as far.

Other factors affect the spread width:

Type of slug pellet. Typically, a large, dense hard pellet should spread further than a small, light, soft pellet, because it is comparatively heavy and does not powder on the disc. Typically, a 'wet' produced pellet will be hardest, a steam produced pellet mid range, and a dry produced pellet the softest. However, the line between traditional 'mini' pellets and 'full size' is blurred – most are of similar size and some lower priced dry produced pellets termed, as 'minis' are actually larger and heavier than more expensive wet produced pellets, and can have a good spreading characteristics.

Seed varieties and dressings. Different varieties and dressings will affect the density and the spread.

Wind Conditions. Dead calm conditions are the optimum: any wind will affect the width pattern.

High forward speed. The same as driving into a headwind of the same speed on a calm day, this will peel the edges of the spread pattern backwards and inwards.

Disc speed. Altering the disc speed will affect the width and pattern. A higher disc speed will give a wider spread width.

Disc condition Ensure in good condition and not worn excessively. Replace if necessary.

Low disc height. Will not allow the product to reach its maximum width before gravity takes over.

Low electrical power. Will not allow the disc to reach full speed.

High application rates. Loads the disc more than a lighter rate and can slow it down.

Incorrect disc angle. It must be at least horizontal – not angled downwards.

It is the responsibility of the operator to ensure that no other persons enter the spreading zone whilst the machine is in operation.

16.0 Calibration Hopper

Part No. FJ-005-CAL-MINI

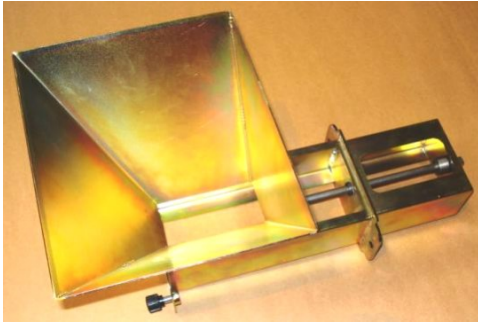

Calibration Hopper is included as standard with the machine.

16.1 Fitting Instructions

1. With an empty hopper, remove the feed block assembly from the machine.



2. Slide the Calibration Hopper into the Fan Jet in place of the feed block with the hopper uppermost, ensure the drive shaft aligns and secure with the supplied screw knobs.



3. Insert the (removed) feed block into the Calibration Hopper, ensure the drive shaft aligns by slowly rotating the feed shaft.



4. Secure with the two small black PVC knobs supplied.



5. Place a suitable container under the Calibration Hopper to collect pellets whilst calibrating.

17.0 Fan Jet Mini i-CON Parts Diagram

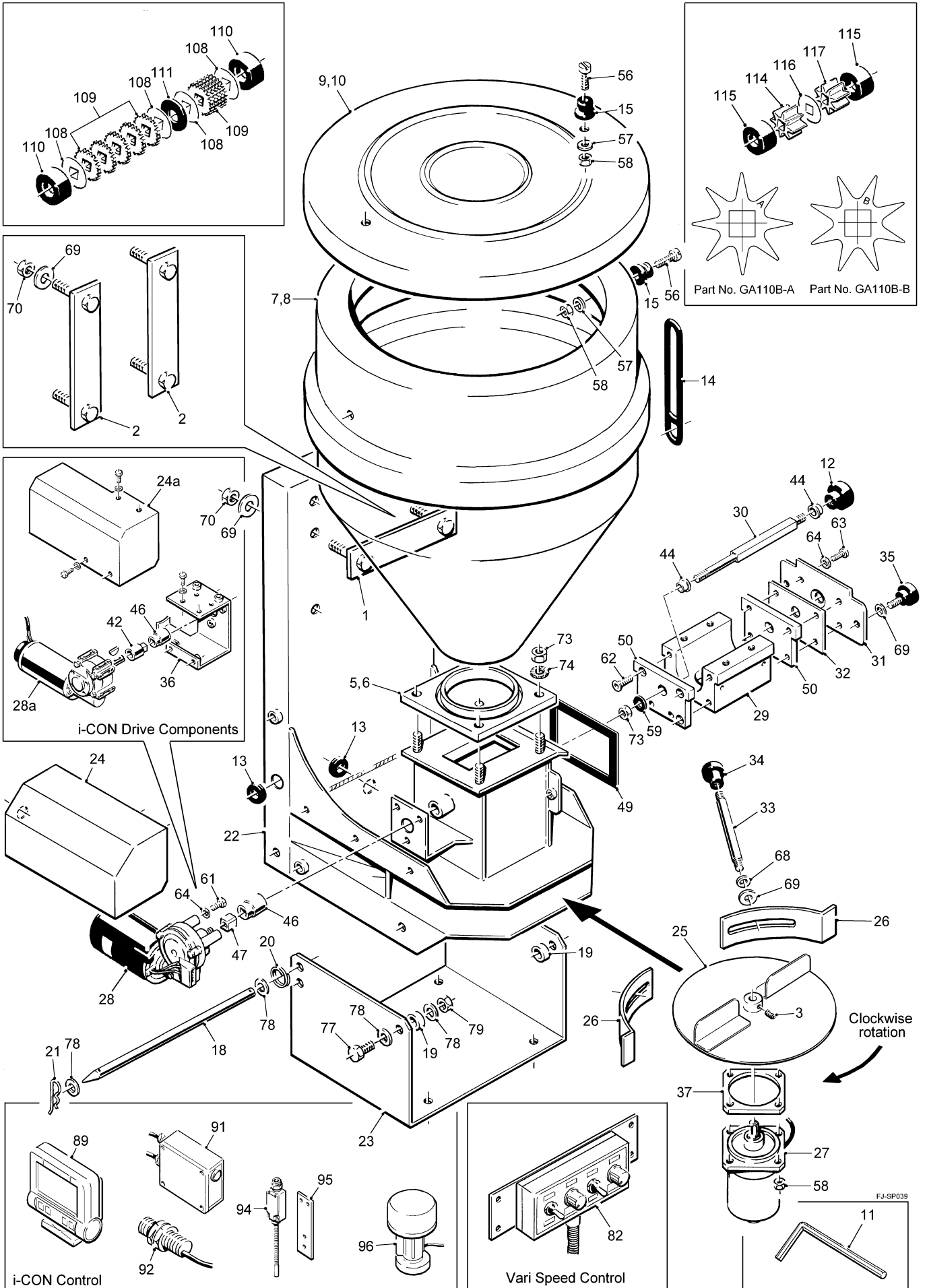

17.1 Fan Jet Mini Parts List

Item	Part #	Description	Qty	Remarks
1	FJ003A	Hopper Bracket	1	65L
2	FJ003A	Hopper Bracket	2	130L
3	FJ008A	M6x6mm Grub Screw	2	
5	FJ017D	Hopper Base Plate	1	
6	FJ017S	Base Plate Seal	1	(not shown)
7	FJ026A-Ass.	65 Litre Hopper Assembly	1	
8	FJ026B-Ass.	130 Litre Hopper Assembly	1	
9	FJ027A-Ass.	65 Litre Hopper Lid Assembly	2	
10	FJ027B-Ass.	130 Litre Hopper Lid Assembly	2	
11	FJ028A	3mm Allen Key	1	
12	FJ033A	M8 Female Knob	1	
13	GR005	Rubber Grommet	2	
14	FJ103A-1	Rubber Tensioner	2	Qty x 3 on 130L
15	FJ104A-1	Bobbin	4	Qty x 6 on 130L
17	TJ131	4mm Allen Key	1	(not shown)
18	FJ415B	Tipping Pin	1	
19	FJ417A	Nylon Spacer	2	
20	FJ418A	Split Ring	1	
21	FJ419A	3mm "R" Pin	1	
22	FJ500B	Chassis Weld Assembly	1	
23	FJ514B	Tipping Base Plate	1	
24a	FJ549A-Ass	Motor Guard Assembly	1	
25	MFJ007A	Disc Assembly	1	
26	FJ509A	Deflector	2	
27	FJ057D	Disc Motor	1	
28a	TJ044B	Feed Motor	1	
29	GA108	Feed Block	1	
30	GA113B	Feed Shaft	1	
31	FJ540B	Feed Block Mounting Plate	1	
32	FJ539A	Block Packer	1	
33	FJ030A	Deflector Knob Tube	2	
34	FJ032A	M8 x 8.5 Knob	2	
35	FJ032B	M8 x 15 Knob	2	
36	FJ548A-Ass.	Motor Bracket	1	
37	FJ736B	Motor Spacer Plate	1	
42	TJ043	Motor Drive Coupling	1	
46	MM048	17mm Drive Socket	1	
47	MM049	Drive Square	1	
49	TJ040	Feed Block Gasket	1	
50	GA109	Feed Block End Plate	2	

17.2 Fan Jet Mini Parts List Continued

Item	Part #	Description	Qty	Remarks
51	MD005	Decal "FAN JET"	1	(not shown)
52	MD008	Decal "Mini"	1	(not shown)
53	MD052	Decal "Warning" Keep Clear - Wear PPE	1	(not shown)
54	MD050	"Warning" Decal Set- Thrown or Flying objects	1	(not shown)
55	MD002	Decal "STOCKS AG"	1	(not shown)
56	M5-012	M5x25 Slot Head CSK Screw	4	Qty x 6 on 130L
57	M5-014	M5 Flat Washer	4	Qty x 6 on 130L
58	M5-017	M5 Nyloc Nut	8	Qty x 10 on 130L
59	TJ033	Feed Block Gasket	1	
60	MD022	Decal "i-CON"	1	(not shown)
61	M6-004	M6 x 16 Hex Head Set Screw	3	
62	M6-007	M6x20 CSK Set Screw	4	
63	M6-008	M6x25 Button Head Set Screw	4	
64	M6-016	M6 Flat Washer	7	
68	M8-010	M8 Flat Washer	1	
69	M8-012	M8 Repair Washer	3	Qty x 5 on 130L
70	M8-017	M8 Nyloc Nut	2	Qty x 4 on 130L
73	M10-023	M10 Nut S/S	5	
74	M10-026	M10 Shakeproof Washer S/S	4	
77	M12-006	M12x40 Set Screw	2	
78	M12-008	M12 Flat Washer	6	
79	M12-014	M12 Nyloc Nut	2	
80	GA103	PVC Flanged Bush	2	(not shown)
89	TJ117C	i-CON Instrument Panel	1	
90	TJ235	Instrument Mount	1	(not shown)
91	TJ119D	Junction Box	1	
92	TJ251A	Hopper level Sensor	1	
94	TJ252	Finger Switch	1	
95	TJ253	Mounting Plate	1	
96	TJ255B	GPS Receiver	1	
97	FJ107F	7m Fused Power Cable	1	(not shown)
98	TJ118C	Instrument Connector Cable	1	(not shown)
99	TJ242A	6m Instrument Cable	1	(not shown)
108	TJ199	Stainless Steel Shim	4	
109	TJ200	5mm Small Seed Roller (White)	10	
110	GA114	24mm Black Spacer	2	
111	TJ207A	3mm Black Spacer	1	
110	TJ205	5mm Black Blanking Spacer	8	(not shown)
114	GA110B-A	8 Section Feed Roller (A)	1	
115	GA114	24mm Black Spacer	2	
116	TJ199	Stainless Steel Shim	1	
117	GA110B-B	8 Section Feed Roller (B)	1	

